

CAHIER  
LOUIS-LUMIÈRE

no.  
14

# Aaton : A new take on cinema

Scientific coordinators :  
Giusy Pisano et Gilles Mouëllic

MARIANNE BAUER  
BÉRÉNICE BONHOMME  
BRUNO CARRIÈRE  
CAROLINE CHAMPETIER  
SIMON DANIELLOU  
ALEXIA DE MARI  
ANTONY FIANT  
HÉLÈNE FLECKINGER  
THOMAS GODEFROY  
ÉRIC HURTADO  
PASCAL MARTIN  
JEAN-BAPTISTE MASSUET  
VALENTINA MIRAGLIA  
VANESSA NICOLAZIC  
CAMILLE PIERRE  
MARTIN ROUX  
VINCENT SORREL  
FRÉDÉRIC TABET  
NICOLAS TIXIER  
THOMAS WEYLAND

Translate by Elodie Bourgneuf

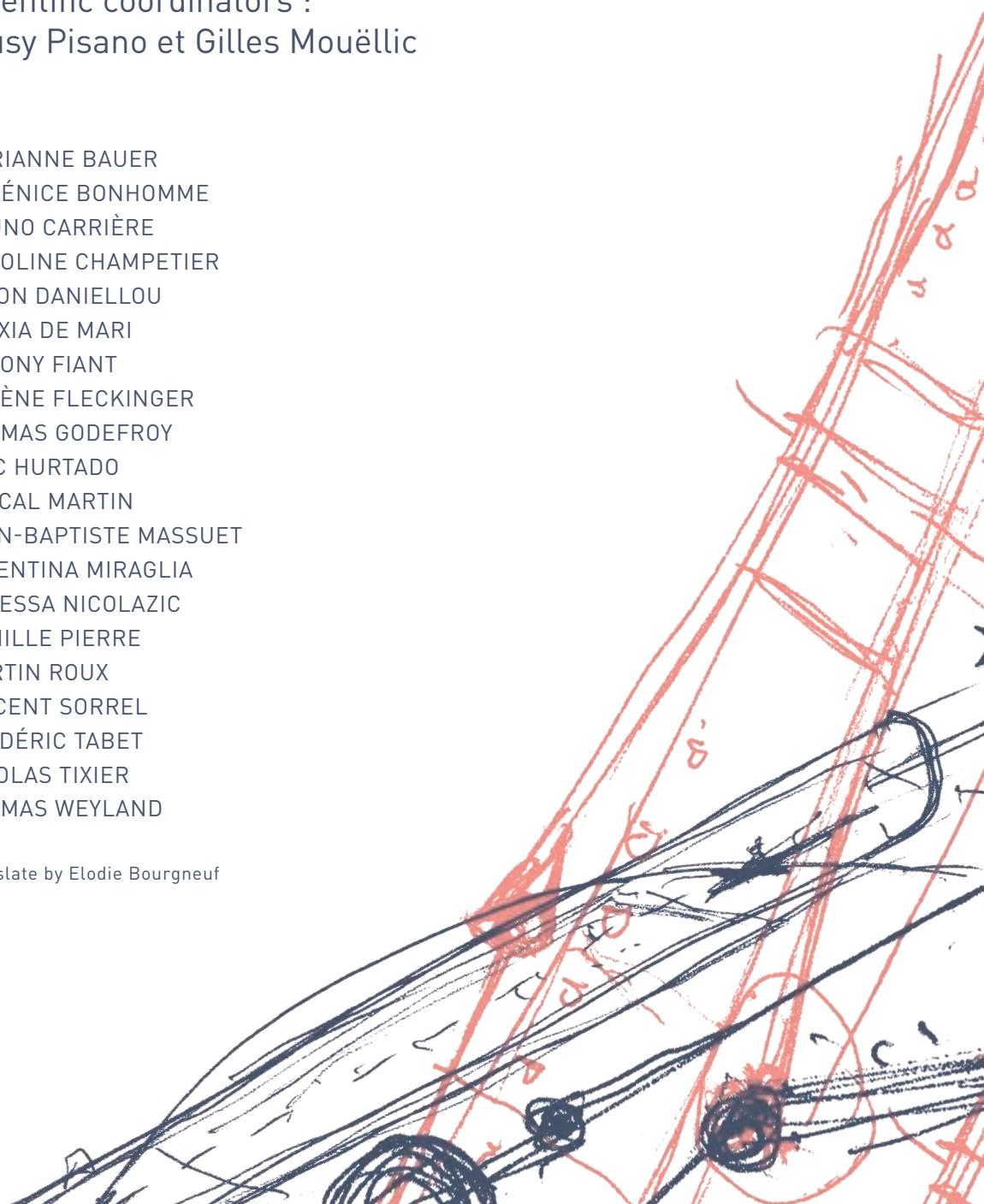

## A new take on Cinema

Scientific coordinators: Gilles Mouëllic and Giusy Pisano

**P.5**

**Foreword**  
Vincent Lowy

**P.7 À 10**

**Renewing the Articulations  
between Academic Research,  
Film Schools and the History  
of Techniques: from Technès to  
Beauviatech**  
Gilles Mouëllic

**P.11 À 18**

**Introduction: In Praise of  
Hybridity**  
Giusy Pisano

**1.**

### Aaton through the Archives

**P. 23 À 28**

**The Commitment of the  
Cinémathèque française:  
Ten Questions for Joël Daire,  
Heritage Director**  
Gilles Mouëllic

**P. 29 À 38**

**The Study of the Aaton  
Collection: A Challenge to  
Cinema Research and a Sign of  
the Times**  
Alexia de Mari and  
Jean-Baptiste Massuet

**P. 39 À 53**

**The Aaton Film Collection:  
Technical Tests and Slices of  
Life**  
Marianne Bauer and  
Simon Daniellou

**2.**

### Imagining, Designing, Reinventing, Patenting, Experimenting

**P. 57 À 60**

**Jean-Pierre Beauviala before  
Aaton: From High School to Éclair**  
Alexia de Mari

**P. 61 À 68**

**Jean-Pierre Beauviala:  
Thoughts on Inventions**  
Bérénice Bonhomme and  
Frédéric Tabet

**P. 69 À 71**

**A Founding Patent: The Claw  
Movement of the Aaton 16**  
Alexia de Mari

**P. 72 À 76**

**Visualizing Time: Chronometric  
Marking According to Aaton  
(1970–1987)**  
Vanessa Nicolazic

**P. 77 À 78**

**The Single System - The Unloved  
Invention**  
Jean-Baptiste Massuet

**P. 79 À 80**

**La Paluche, "The Eye at Your  
Fingertips"**  
Hélène Fleckinger

**P. 81 À 86**

**From the 8–35 to the Aaton 35**  
Vanessa Nicolazic and  
Vincent Sorrel

**3.**

### The Aaton Company

**P. 91 À 115**

**The Visit to Grenoble: The Aaton  
Factory Manufactures Images  
and Sounds**

Vincent Sorrel and Nicolas Tixier

**A Journey of Happy  
Coincidences**

Bruno Carrière

**An Aatonian in Grenoble**

Valentina Miraglia

**Not to Film but to Sing with a  
Camera**

Éric Hurtado

**The Mechanical Curvature of  
the Film**

Vincent Sorrel

**P. 116 À 128**

**Aaton at Work: Photographic  
Tracks**

Caroline Champetier,  
Pascal Lagriffoul and Alain  
Sarlat

**P. 129 À 135**

**Jean-Pierre Beauviala in the  
*Cahiers du cinéma*: The Story of  
the Inventor**

Thomas Godefroy

---

#### 4. The Delta Penelope and the Cantar: Experiences and Practices

- P. 139 À 144**  
The Penelope Delta: The Last  
Tactile Camera  
Martin Roux
- P. 145 À 149**  
Optical Viewfinding  
Pascal Martin
- P. 150 À 152**  
The Workshop "Filming with the  
Delta Penelope"  
Giusy Pisano and Pascal Lagriffoul
- P. 153 À 165**  
Learning the Image: From the  
Camcorder to the Delta Penelope  
Thomas Weyland
- P. 166 À 172**  
Handling the Cantar: The  
Implementation of a Working  
Gesture  
Camille Pierre
- P. 173 À 180**  
The Sound of the Cantar:  
Interview with Jean-Pierre Duret  
Camille Pierre

---

#### 5. Invention of New Tools for New Aesthetics

- P. 185**  
Experimenting with the Paluche:  
*Urban Sax in Venice* (1981) by  
Bénédicte Delesalle and Marie-  
Ange Poyet  
Hélène Fleckinger
- P. 187**  
An Exercise of Reflexivity: *Ciné-  
portrait of Raymond Depardon* by  
Jean Rouch and *Vice Versa*  
Antony Fiant
- P. 190**  
Good-Bye Camera: The 8-35 and  
the Clouds of *Passion* (Jean-Luc  
Godard, 1982)  
Vincent Sorrel
- P. 193**  
The Aaton XTR on the Set of *Route  
One/USA* (Robert Kramer, 1989)  
Simon Daniellou
- P. 195**  
Filming the Emergence of Speech:  
*Entre les murs* (Laurent Cantet,  
2008)  
Gilles Mouëllic
- P. 197**  
*The Hurt Locker* (Kathryn Bigelow,  
2008) and the A-Minima Camera  
Jean-Baptiste Massuet
- P. 200**  
The Performances of the Cantar  
Put to the Test in a Sequence of  
*Holy Motors* (Leos Carax, 2012)  
Gilles Mouëllic
- P. 202**  
Aaton Cameras on the Set of *First  
Man* (Damien Chazelle, 2018)  
Simon Daniellou
- P. 204**  
Selected Biography



## Foreword

| Vincent Lowy

From the outset, we knew that this Cahier Louis-Lumière dedicated to the Aaton years would be special.

We had no concerns over the seriousness of the endeavor: Gilles Mouëllic and Giusy Pisano have a solid reputation for their work on the history of cinematographic techniques, and we had no doubts that they would mobilize a large cohort of specialists entirely devoted to the Aatonian cause.

Well established, the wonderful Beauviatech research program continues, come virus or high water, at the University of Rennes 2. And although the traditional “on-site” conferences and symposiums have obviously been postponed, this review in itself constitutes an authoritative publication, appearing as a main course on the menu of this program financed by the ANR which extends over several years and investigates the relationships between technology and aesthetics, starting with the archives of the Aaton Company. Other landmark publications include Gilles Mouëllic and Antoine de Baecque’s *Godard/Machines*, published by Yellow Now in 2020, but this fourteenth issue of the Cahier Louis-Lumière will nevertheless long remain one of the highlights in the history of our young magazine.

It all began in 2018, in the crackling of a small force field which brought together the team gathered around Gilles Mouëllic in Rennes (Jean-Baptiste Massuet, Marc Christie, Laurence Bouvet-Lévêque and the doctoral students Elisa Carfantan and Alexia de Mari), the friends and trustees of the Cinémathèque française and its Conservatoire des techniques (Joël Daire and Laurent Mannoni), the wider circle of the

Technès international partnership and other amateurs of the epistemology of techniques (Hélène Fleckinger, Benoît Turquety, Vincent Sorrel, André Gaudreault, Laurent le Forestier, Kira Kitsopanidou, Simon Daniellou, Éric Thouvenel, Priska Morrissey, some are missing) and a few fine swordsmen from the ENS Louis-Lumière federated by Giusy Pisano: Martin Roux, Pascal Lagriffoul, Pascal Martin, Alain Sarlat... Everyone gathered around Caroline Champetier and Jean-Pierre Beauviala, for a trip back in time in the form of a farewell ceremony, until the day of departure (8 April 2019).

For all of us, Jean-Pierre ... those were the blooming years: we know the city of Grenoble by heart, the place he invented Aaton in 1971, the way he made a point in plowing his furrow as an idealist, with a love and an obsession for the right idea and the calculated risk... We must thank his parents, who in the middle of the fifties, out of bourgeois conformism and informed provincialism, forbade him the noble pathway of the Parisian Beaux Arts of the rue Bonaparte to send him among engineers in Grenoble. It’s hard to imagine what Jean-Pierre Beauviala’s career would have been like if he had been an artist in Paris at the age of 25 rather than an electronics teacher in Isère. Incidentally, when Éclair lays him off, circumstances allow him to quickly return to the Rhone mists where he establishes himself permanently and where he now rests, between the Dévoluy and the Vercors, the Écrins and the Belledonne mountains.

There was an art gallery in Lyon in the 1970s on the quays of the Saône called *L’œil écoute* [the eye listens]. Albeit simple, this synesthesia magnificently summarizes Beauviala’s approach throughout the so-called “Aaton years.” For out of the crucible of this scruffy alchemist emerged machines regarded not ▶

as cumbersome, but as a natural extension of the technician's body. True phenomenological prostheses, the LTR and XTR series, the Paluche, the A-Minima, the Penelope and all the associated experiments, from the sublime Cantar to the dreamed Libellule of the last weeks, redefined the relationship between technicians and the recording of reality, offering several generations of filmmakers, from Jean Rouch to Leos Carax, the devices they needed to dream their images and sounds. Caroline Champetier understands better than anyone what these devices, infinitely perfectible and designed to be, have brought to film professionals: she has widely contributed to the iconographic contents of this Cahier and we thank her.

The multiple contributors brought together in this volume tell this story, each in their own way, each with their own methodologies and approaches. They're returning Jean-Pierre Beauviala a piece of what he gave them. Our École does the same, in this compilation in praise of the provinces and of time regained. Of course, we would have liked him to hold this Cahier in his hands... But if all our students take a hold of it and bring it home, we know that deep down it's exactly what he would have wanted.

It is in that sense a particular source of pride and emotion to find included here an article by one of our students, Thomas Weyland, entitled *Learning the Image: From the Camcorder to the Delta Penelope*. It is perhaps the best possible tribute we could give to the memory of Jean-Pierre Beauviala. For, as Diderot's *Rameau's Nephew*, he could have said: "I learned by teaching others, and I turned out some good pupils..."

#### VINCENT LOWY

**Vincent Lowy is a university professor and director of the École nationale supérieure (ENS) Louis-Lumière. His research activities are part of the ISOR Axis of the Centre d'histoire du XIX<sup>e</sup> siècle (Paris 1 - Sorbonne University - EA 3550) and focus on the relationships between history and cinema and social and memorial representations. He has directed several collections of books on the history and aesthetics of cinema at Le Bord de l'eau Éditions, where he has notably published *Marcel Ophuls (2008)*, *Cinéma et mondialisation (2011)* and more recently with Arnaud Duprat *La Maman et la putain, politique de l'intime (2020)*.**

*Vincent Lowy est professeur des Universités et directeur de l'École nationale supérieure Louis-Lumière. Ses activités de recherche s'inscrivent dans l'Axe ISOR du Centre d'histoire du XIX<sup>e</sup> siècle (Paris 1 – Sorbonne Université – EA 3550) et portent sur les rapports histoire/cinéma et les représentations sociales et mémorielles. Il a dirigé plusieurs collections de livres sur l'histoire et l'esthétique du cinéma chez Le Bord de l'eau Éditions, où il a notamment publié *Marcel Ophuls (2008)*, *Cinéma et mondialisation (2011)* et plus récemment avec Arnaud Duprat *La Maman et la putain, politique de l'intime (2020)*.*

## Renewing the Articulations between Academic Research, Film Schools and the History of Techniques: from Technès to Beauviatch

| Gilles Mouëllic

On December 28, 1895, a handful of spectators attended the first commercial public screening of the cinematograph in the basement of the Grand Café, boulevard des Italiens in Paris. The first patent for the device was filed by the Lumière brothers on February 13, 1895, the year the conditions were met to design a machine whose qualities derived from a compilation of the characteristics of Thomas Edison's kinoscope, Etienne-Jules Marey's chronophotograph and the technical innovations specific to the cinematograph. Beyond the practical aspect of this dating, the question of the invention of cinema has not failed to raise numerous controversies involving the history of techniques and cultural history. Innovations will continue to play a significant role in the structuring of the history of cinema: the advent of "sound," the introduction of color processes, the competition from television, the portability of imaging and sound recording devices, the generalization of Dolby sound systems or even the mastery of "3D."

The study of these different stages requires skills which remained for long the exclusive domain of technicians and engineers who were not very inclined to go beyond their fields of expertise. Technical history has therefore been relatively marginalized, and its articulation with other fields of film history (institutional history, history of forms) and with aesthetic analysis, which have become the two dominant fields in research, has remained limited to a few modest attempts. The rapid adaptation of

cinema to digital means, which heralds what some call the "digital revolution," will, however, require considering techniques in much more concrete terms in order to understand all the ongoing changes. The fields of production, distribution and conservation of movies are undergoing profound upheavals, linked to a complete transformation of media and machines due to the evolution from chemical inscription on silver-based media to digital encoding. This configuration seems a priori largely unprecedented, simultaneously affecting industrial, amateur or experimental practices, with significant consequences on all discourses, including film and media studies. This development imposes technological issues as a major subject in a large number of fields: economics, film restoration, aesthetics, ontology, epistemology, etc.

The Technès program (*Audiovisual Technologies and Their Uses: History, Epistemology, Aesthetics, 2015/2022*) falls within this context with the ambition to place the technical dimension at the center of academic thinking on cinema. In 2013, an International Research Partnership was established with three universities (Lausanne, Montreal, Rennes 2), four film schools (ECAL in Lausanne, INIS in Montreal, École Nationale Supérieure Louis Lumière and Fémis in Paris) and three national cinematheques (Swiss, Quebec and French). The purpose of this cooperation, unprecedented at this level, between research, vocational training and the conservation and distribution of films is to develop synergies between all the fields that are concerned by digital conversion. More than a hundred researchers and PhD students willing to expand their horizons to technological issues while creating a space for dialogue with cinema technicians are now included in Technès. ►

The first scientific events organized as part of the partnership allowed to put the “revolutionary” dimension of the advent of the digital cinema into perspective. Analysis of previous technical upheavals already identified by history and theory has, indeed, revealed recurrences, echoes, similar technical configurations that contribute to putting contemporary transformations into perspective. Several studies point out, for example, the analogies between the digital transition and the advent of television in the fifties which will be followed, twenty years later, by the democratization of analog video. Other historiographical research testifies to the relevance of the problems that have appeared during two centuries of development of sciences and technology to understand what is at play today with the generalization of digital. The researchers involved in Technès thus contribute to understanding the contemporary world in light of a history of technologies, the first manifestations of which precede the invention of the cinematograph by several decades. This collective will to place digital technology in long-term history implies new approaches requiring innovative collaborations between academics from several fields (visual studies, economics, socio-history, anthropology), engineers, practitioners and institutions such as the Conservatory of Techniques of the Cinémathèque française. The technological history of cinema, which is based on filmed works, on textual sources and on non-textual sources (material, achievements, etc.), must thus jointly organize the history of mechanisms, the history of devices, the history of machines and the history of practices. At each of these levels, aesthetic, epistemological, historical and methodological questions appear.

The digital transition affects all stages of the making of a film, from its preparation to its release to the public. If movie theaters have managed to retain their status as the privileged movie screening setting, the proliferation of viewing devices (mobile phones, computers, “home cinemas” etc.) has led to a notable change in consumption patterns (and therefore perception) of images and sounds. Digital technologies have also had important consequences on the making of films, the most visible part concerning the proliferation of increasingly sophisticated special effects. The nine episodes of the *Star Wars* saga, produced between 1977 and 2019, are a true laboratory for the study of the way in which technologies are a source of formal inventions due to continuous collaborations between artists and engineers. Digital possibilities determine just as much, by other mechanisms, the advent of long televised series over several seasons, the birth of new forms the documentaries, with increasingly lightweight and powerful cameras and sound recorders, or the existence of very technically sophisticated not very spectacular films of fiction: *Entre les Murs* (Laurent Cantet, 2008), filmed for the most part in a Parisian college classroom, would not exist in this form without the possibility of continuously filming young amateur actors over very long periods of time with multiple cameras and digital recorders.

Understanding these articulations between the technical and the aesthetics requires taking into account the implications of digital means on the evolution of film professions. In the span of a few years, sometimes in the span of a few months, directors, actors, decorators, scriptwriters, sound engineers, camera operators, editors, mixers, music composers, have been forced to adapt to new





**Aaton was both at the origin of technical innovations linked to silver-based film and analog video, and a major player in the transition to digital practices.**

machines that have deeply transformed all practices. Understanding and documenting what these professions become is at the heart of the Technès project, but this mission is once again inseparable from the creation of a memory of the gestures associated with working with the film roll, gestures which have conditioned the first century of the existence of cinema. In order to understand the specificities of the relationship between men and machines, a team from Rennes submitted to the ANR (National Research Agency) a research program integrated to Technès and devoted to the archives of the French company Aaton, created and managed from 1971 to 2013 by engineer and inventor Jean-Pierre Beauviala (1937-2019). This program named Beauviatech (*Jean-Pierre Beauviala and the Aaton Company: Audio-Visual Techniques and Their Uses; Historical, Aesthetic and Practical Modalities*) procured important financing for the 2019/2022 period. Aaton was both at the origin of technical innovations linked to silver-based film and analog video, and a major player in the transition to digital practices. The exploration of this archive collection deposited at the French Cinémathèque allows for the study, based on specific examples, of the technical choices which drive the invention and the evolution of devices, thought up by the engineers of Aaton in close collaboration with users, camera operators and sound recorders. To carry out this program, the researchers of the Department of the Performing Arts of Rennes 2 partnered with members of l'IRSA (Institute of Research in Computing and Random Systems), Mixed Research Unit based in Rennes 1, in the Fémis and at the École nationale supérieure Louis-Lumière, the prominent training schools for audio-visual and film professionals in France.

If a significant part of the work done within the framework of the Technès partnership is intended for the academic community, the societal implications of the history of

techniques, well beyond the digital transition itself, make it desirable for the results of the research to be much more widely available. Technès' ultimate project is therefore to create an *Encyclopaedia of Film Techniques*, online and constantly updated, which will be inaugurated in June 2021 at the *Il Cinema Ritrovato* festival in Bologna, Italy. This digital platform, whose funding is provided by the Council of Research in Social Sciences of Canada (CRSH), is an interactive and innovative space, likely to interest academics, professionals and the general public. It will act for the preservation of memory by archiving, particularly in the form of fixed or moving images, of filmed interviews, of 3D digitalization and device demonstrations, an unheralded part of the world's cinema heritage. While offering a global understanding of the challenges of the digital transition, the *Encyclopaedia* will open the way to new practices in historical visualization, in heritage promotion and in distributing educational content.



## GILLES MOUËLLIC

Gilles Mouëllic is professor of film studies at the University of Rennes 2. His current work focuses on the relationship between technique and aesthetics as well as on improvisation as a mode of creation in cinema. His latest publications are *Godard/Machines* (Yellow Now, 2020), co-edited with Antoine de Baecque; *Techniques et machines de cinéma : objets, gestes, discours* (Écrans/Classiques Garnier magazine, 2020), co-edited with Laurent Le Forestier and Benoît Turquety; *Johan van der Keuken: documenter une présence au monde* (Yellow Now, 2020), co-edited with Antony Fiant and Caroline Zéau.

*Gilles Mouëllic enseigne le cinéma à l'Université Rennes 2. Il dirige pour la France le partenariat international de recherche Technès et codirige, avec Jean-Baptiste Massuet le programme ANR Beauviatech. Ses travaux actuels portent sur les relations entre techniques et esthétiques ainsi que sur l'improvisation en tant que mode de création au cinéma. Ses dernières publications, toutes associées au programme Technès, ont pour titre Godard / Machines (Yellow Now, 2020), en codirection avec Antoine de Baecque ; Techniques et machines de cinéma : objets, gestes, discours (revue Écrans/Classiques Garnier, 2020), en codirection avec Laurent Le Forestier et Benoît Turquety ; Johan van der Keuken : documenter une présence au monde (Yellow Now, 2020), en codirection avec Antony Fiant et Caroline Zéau.*

## Introduction: In Praise of Hybridity

| Giusy Pisano

Utensils that are a priori entirely reducible to their functionality can become objects as unique as the people who own them and make them work. The completely standard character of the object is gradually altered by adaptation and marking procedures. With our camera or our boat, we all build affinities and intimate connections that transform the tool, way beyond the extension of the hand or an instrument of reason, into an alter ego. Between the churinga and the coffee grinder, two experiences of 'the thing' can be grasped, one in the realm of the strange, the other in the realm of the familiar. Whereas in religious rites the irruption of the thing, skillfully generated and staged, turns it practically into a person (a subject), the daily use of common objects and their capacity to answer us ('the feedback of reality') gives them a life that is inseparable from the one of their owners. It is therefore necessary, with Mauss, to seriously consider the singularity and 'the soul' of things and understand that a gift is never an exchange. Visible token of a personal and collective history, it opens an infinite debt, and beyond, a circuit of singular objects, a transfer of personalized things<sup>1</sup>.

On October 13 and 14, 2011, the Cinémathèque française organized a symposium named *Digital Revolution: What if Cinema Lost Its Memory?* Among the participants: Jean-Pierre Beauviala, the president of the Aaton Company, until 2013. He proposes the

large audience in the Henri Langlois hall a dialogue around the question *Towards a hybrid cinema?* The idea of a possible hybridity that could allow for the preservation of the best of silver-based film in the digital realm, "to temper the loss, to limit the differences between film and digital,"<sup>2</sup> was never abandoned by the inventor. Jean-Pierre Beauviala added touches of this hybridity, sometimes with little scientific evidence: in the same symposium, when he stated that "the autochrome is exactly the principle which is used in the best performing digital cameras"<sup>3</sup> and launched the project of a digital sound recording device with two optical stereo tracks, *visible to the naked eye*; in his conversations with the students of the ENS Louis-Lumière he stressed the importance of continuing to teach silver-based film (March 13, 2018); when he imagined tools that resulted from the observation of gestures and lastly, in his last patent for the Delta Penelope camera.

### Aaton: Imagining Tools through Gestures

Director Éliane de Latour has experimented with the interconnections of tools and gestures in all her films:

As we were rock, reggae, or rap, we were 'aatonien,' and in good company. Albert and David Maysles, Ricky Leacock, Michel Brault, Jean-Luc Godard, Louis Malle, Pierre Perrault, Jean Rouch, and on the activist side: Renaud Victor, Richard Coppans... For twenty-five years, all my films were shot with Aaton cameras. My path followed their evolutions: LTR 16 mm, XTR Super 16 mm, 35 mm with accessories ►

<sup>1</sup> BAZIN J., Bensa Alban, « Les objets et les choses : Des objets à la "chose" ». In: *Genèses*, 17, 1994, p. 6.

<sup>2</sup> GRIZET D., *Les appareils de prise de vues de la société Aaton (1971-2013). Du « direct » au « numérique » : enjeux techniques et esthétiques*, Master's thesis, Recherche en Études cinématographiques, under the supervision of MOUËLLIC G., Université Rennes 2, 2017, p. 87.

<sup>3</sup> See: [https://www.canalu.tv/video/cinematheque\\_francaise/vers\\_un\\_cinema\\_hybride\\_dialogue\\_avec\\_jean\\_pierre\\_bauviala.7767](https://www.canalu.tv/video/cinematheque_francaise/vers_un_cinema_hybride_dialogue_avec_jean_pierre_bauviala.7767)

invented over the days by Jean-Pierre Beauviola. Integrated time code, comb shutter (never sold), white magazines against the sun (never sold), black frame in the viewfinder (never sold). I liked to frame. It's something that can't be learned but that you feel inside, with impressions of failure, relevance or euphoria in moments of fusion with a gesture or a light: two notes which suddenly vibrate together<sup>4</sup>.

These impressions of relevance, of euphoria, of failure, of fusion with a gesture or a light are evoked by the professionals who have had the opportunity to use the Delta Penelope camera: an unusual digital camera, tactile rather than digital. As Martin Roux emphasizes, with its shutter fitted with a classic rotating mirror, its flexible device randomly shifting the physical position of the sensor by half a pixel for each image, it gives the *impression* of regaining the aesthetic quality of the film roll. Its optical viewfinder, on which Pascal Martin focused his attention, "offers a particular feeling that is almost timeless, because nothing tells the person using it whether the recording is done on a sensor or on an emulsion behind the lens." And he adds: "Doesn't the flicker caused by the shutter (mainly on highlights) create, even unconsciously, a resonance with film projection?"<sup>5</sup>

Beyond the qualities or defects attributed to this camera that remained a prototype, for Thomas Weyland, it "allows apprentice operators to learn the ropes ... forces to think the limits, to confront them and to find solutions that allow to exceed them, and possibly come back to them later to go even further."<sup>6</sup> The reason that explains why the École nationale supérieure Louis-Lumière devoted

an educational workshop to the Delta Penelope, and why in this issue of the *Cahier ENS Louis-Lumière* it is a subject of focus to teachers, students and ex-students lies in the perspective of the ontological project which presided over its invention: to locate the aesthetic stake in the confluence of the gesture and the tool because "its entire conception is an invitation to the manual apprehension of the operator, be it the rotary selector, the optical viewfinder, or the shape of the camera made to fit to the shoulder."<sup>7</sup> In contrast, therefore, to the increasingly disembodied perception of the digital tool. Hence the challenge of the educational workshop "Filming with the Delta Penelope" that allowed students to reflect on the concept of a *prototype*, of the non-standardized, thus leaving open the possible responses to technical constraints.

Among the devices built by the Aaton Company, the Cantar, the first eight-track digital sound recorder, is also special in its design. The latter results from the *praxis*, "the gestures involved in handling the recorder, the way in which the device allows movements and influences them are important during the phase of the development of the object but also for its integration in work."<sup>8</sup> It is through the observation of working gestures, through discussions with sound engineers that the Cantar had been designed to meet the constraints of the profession: fast, discreet, flexible. As Jean-Pierre Duret testified to in an interview with Camille Pierre: "the essential thing is to maintain lightness, the proximity with the performance, with the set and the scene in the making, which the Cantar allows."<sup>9</sup> It is this principle that tools need to be designed from gestures which is at the heart of the collaboration between the ENS Louis-Lumière and the ANR Beauviatech project; such as this

<sup>4</sup> DE LATOUR E., "La fausse bataille de l'art et de la science. Mise en scène cinématographique en ethnologie," *Revue française des méthodes visuelles*, [Online], 2 | 2018, posted on July 12, 2018, consulted on 08/11/2020, URL: <https://rfmv.fr>.

<sup>5</sup> MARTIN P., "Optical Viewfinding," p. 145-149.

<sup>6</sup> WEYLAND T., "Learning the Image: From the Camcorder to the Delta Penelope," p. 153-165.

<sup>7</sup> ROUX M., "The Penelope Delta, the Last Tactile Camera," p. 139-144.

<sup>8</sup> PIERRE C., « Manier le Cantar : la mise en œuvre d'un geste de travail », p. 166 à 172.

<sup>9</sup> PIERRE C., « Le son Cantar : entretien avec Jean-Pierre Duret », p. 173 à 180.

publication that brings together academics, archivists, professionals, teachers, students, around the Aaton Company (1971-2013) whose inventions have always been imagined by users (technicians and filmmakers).

## Life in the Factory and in the City

The objects in question here belong to both a personal and collective history: of Jean-Pierre Beauviala—the inventor, artist, industrialist of the Aaton Company, and of the professionals solicited to discover, test, suggest new tools. Certainly, cameras, sound recorders, accessories, are “objects as unique as the people who own them and make them work.”<sup>10</sup> The premises of the Aaton Company, located in the old quarter of downtown Grenoble, were thought out as a space designed to facilitate exchanges between *Aatonians*, technicians and also filmmakers. The latter frequently visited and on this occasion the prototypes were improved, the devices were experimented with, their qualities were sometimes called into question. “The Visit to Grenoble: The Aaton Factory Manufactures Images and Sounds” is a call that Vincent Sorrel and Nicolas Tixier made in order to collect testimonies on this mythical place; the first responses are published in this issue. The filmmaker and director of photography Bruno Carrière, the filmmaker and visual artist Valentine Miraglia, the photographer-director Eric Hurtado share their memories in rich details though they sometimes date back to 1979. A few days’ stay in Grenoble to discover the very special premises of the factory, try out Jean-Pierre Beauviala’s new jewels and chat with others who arrived at the same time, in particular: Raymond Depardon, Julie Flament, Jean-Pierre Rouette, René Vautier, William Lubtchansky.

<sup>10</sup> BAZIN J., BENZA A., “Les objets et les choses: Des objets à ‘la chose,’” *Genèses*, 17, 1994, p. 6.

Along with these oral testimonies, there are photographic traces which, no doubt, Jean-Pierre Beauviala favored. He let things happen, even in private; he became a model, he was the actor and the complacent eye of the photographer because he was aware that these images would one day constitute as many traces of the public and personal history of the Aaton Company and of Beauviala himself. He was careful not to separate the factory from the city people, the city people from the factory people:

**Aaton is on the street where—as we were able to show yesterday with Raymond [Depardon]—all the people on the street can see what is happening inside a company, in a factory, in workshops, in a word, people at work. It was one of my concerns (...) A city for me was a place of life. Not only a place of merchants, not just a place of dormancy, but it was also a place of work and unfortunately in cities today there is no more work. The work is gone, the real work: the transformation has disappeared, what we call the secondary sector in economics; the primary being mining, agriculture ..., the secondary being transformation and the tertiary being trade. And in the city there is practically no secondary left. Before there were carpenters, coachbuilders, painters...”**

The series of photographs presented by Caroline Champetier and Pascal Lagriffoul opens on an emblematic image: the Aaton mechanical workshops seen through the windows of the rue de la Paix. It continues inside, where prototypists, technicians and filmmakers, “up to their elbows in it,” test the balance of a camera, of a viewfinder, or even the quartz devices for time marking. These photographs ►

<sup>11</sup> MIRAGLIA V., “An Aatonian in Grenoble,” p. 100-109.



The constant exchange with the users of the devices is one of the characteristics of the Aaton Company. In their study of the Aaton archives preserved at the French Cinémathèque

show another important aspect of Aaton's activities: the presentation of its devices at trade shows, such as Photokina. The Aaton factory as a model—militant, committed but also attentive to the market—is also defended through advertising and put forward in the various interventions of Jean-Pierre Beauviala in the press and in particular in *Les Cahiers du cinéma*.<sup>12</sup>

### Draw, Experiment, Redraw to Reinvent and Finally Patent

The constant exchange with the users of the devices is one of the characteristics of the Aaton Company. In their study of the Aaton archives preserved at the French Cinémathèque, Alexia de Mari and Jean-Baptiste Massuet present a hybrid collection of heterogeneous elements “ranging from personal documents—photographs, letters, drawings—to precise and detailed technical files—manufacturing plans, customer files (after-sales service), etc.”<sup>13</sup> Its analysis gives the opportunity to write a history of techniques *in use* in which the human and the technological come together, as the reader will be able to see from one text to another.

Marianne Bauer and Simon Daniellou have more specifically studied from this archive collection film documents that cover the period 1965-2008, from the advent of direct cinema to the digital transition. There too, hybridity reigns: technical essays, rushes, 16 mm, Super 16 and 35 mm formats, production copies, magnetic tapes, digital sound files, family films, documentaries, fictions. Even more so given that the shooting locations are both

private (at Beauviala's) and professional (at Aaton's) and the purposes are of different kinds: formats, cameras, sound recorders suited for film professionals and others for television professionals.

The tests relate both to new prototypes and to commonly used devices that can be transformed and developed. Thus, the Super 9.5 format is tested with a modified camera Beaulieu 9.5; the Super 16 format is tested by modifying an Éclair 16 camera in order to obtain an image much larger than that of the standard 16 mm (+ 40%), for an image ratio of 1.66:1 more suitable for blow ups in 35 mm, but also subsequently to transfer to 16/9 format (i.e. a ratio of 1.78:1). Tests for the 3-perf format are performed with a transformed Aaton 35 camera. As for time marking, it is the subject of numerous tests intended to test two possibilities. On the one hand, the simultaneous recording of images and sounds (preferred by Jean-Pierre Beauviala) by processes such as the “single system.” On the other hand, the independent recording of images and sounds whose synchronization is ensured by a clear-marking system *readable with the naked eye* (a principle Jean-Pierre Beauviala was attached to), such as the system integrated in the Aaton 7 LTR camera (option T) or later, in the mid-1980s, the double time marking (Aaton Code) incorporated in the Aaton XTR cameras and “read,” in post-production, thanks to the dual reading heads of the Linker telecine. For Marianne Bauer and Simon Daniellou, with these tests “thus emerges a Beauviala ‘director,’ who knows what matters to a filmmaker, a cameraman and therefore a camera: the depth of field management, the luminosity, the relationship of the imager to the space and the filmed object (impact of the

<sup>12</sup> GODEFROY T., “Jean-Pierre Beauviala in the Cahiers du cinéma: The Story of the Inventor,” p. 125-135.

<sup>13</sup> DE MARI A. et MASSUET J.-B., “The Study of the Aaton Collection: A Challenge to Cinema Research and a Sign of the Times,” p. 29-38.

ergonomics on the cameraman's movements, panoramic *versus* traveling, 45° viewfinder for low angle and management of the frame tremor) and the respective freedom between the latter and the sound recorder.<sup>14</sup>

Upstream and downstream of a *praxis* where Jean-Pierre Beauviala sometimes plays alternatively the role of director of photography and the role of filmmaker, the drawing is made to set the patent and the prototype to come. In an interview with Bérénice Bonhomme and Frédéric Tabet, he told them: "I often have ideas in the shower: ideas mature through the night. [...] When I arrived at the office in the morning, I made a sketch ... or not even, I certainly explained it to Aaton's chief drafter. I probably didn't do the drawing myself. Once I had the idea, we made a small prototype."<sup>15</sup> In the same interview, he also explained that to rethink a mechanism that did not satisfy him (such as the LTR drive system borrowed from the Éclair) he needed to draw it in order to imagine a new one and patent it.

The patents enlighten this work of invention, correction, and then of reinvention in the genealogy of Aaton devices. They show "an obvious desire for continuity which runs through the history of the company and is characterized by a progressive integration of new technologies."<sup>16</sup> Alexia de Mari<sup>17</sup> notes that patents can have several functions at Aaton: they set innovations; serve as a protection after a lawsuit; preserve future applications. Thus, the single system whose genesis is presented by Jean-Baptiste Massuet rests on three successive patents<sup>18</sup>; the one on the 8-35 was never really conclusive but the experiments on the prototype

made it possible to better think through the Aaton 35 before patenting it<sup>19</sup>; the "Paluche" marketed under the name Aaton 30 was initially intended as a video assist of the Aaton 7, before standing on its own under several successive versions<sup>20</sup>. This "obsession" to improve the existing and not only imagine the new accompanied Jean-Pierre Beauviala from his very first steps in the world of machines when "he perfected the design of an auto-focusing enlarger while still only in high school<sup>21</sup>" and in 1955 when he offered Semflex to modify their phonographic devices in order to optimize the surface of the photographic film. The idea of perfecting the quality of roll film will never leave him, including in the transition to digital technology where this quality will remain his reference. Thus for chronometric marking<sup>22</sup>, despite the transition from the analogical to the pixel, he dreams of a solution that would make it *visible, visible to the naked eye*.

## Reclaiming the Tools to Imagine New Aesthetics

After the genesis of the inventions and the research on the Aaton Company, it was necessary to turn our attention to the films that had used the equipment. Several studies allow us to measure the impact of the machines on the aesthetics of films. The A-Minima cameras, the Paluche, the Aaton 16 LTR, the Aaton XTR Super 16, the 8-35, the Cantar are thus studied in relation to the direction of images and sounds. Yet, to question a film and to interpret it through this alternate point of view and of listening is to assume a posture which is still quite rare in the academic and the film critique worlds. To consider film analysis

<sup>14</sup> BAUER M. et DANIELLOU S., "The Aaton Film Collection: Technical Tests and Slices of Life," p. 39-53.

<sup>15</sup> Cité in BONHOMME B. et TABET T., "Jean-Pierre Beauviala: Thoughts on Inventions," p. 61-68.

<sup>16</sup> GRIZET D., *op. cit.*, p. 90.

<sup>17</sup> DE MARI A., "The Claw Movement of the Aaton 16," p. 69-71.

<sup>18</sup> MASSUET J.-B., "The Single System - The Unloved Invention," p. 77-78.

<sup>19</sup> NICOLAZIC V. and SORREL V., "From the 8-35 to the Aaton 35," p. 81-86.

<sup>20</sup> FLECKINGER H., "La Paluche, "The Eye at Your Fingertips," p. 79-80.

<sup>21</sup> DE MARI A., "Jean-Pierre Beauviala before Aaton: From High School to Éclair," p. 57-60.

<sup>22</sup> NICOLAZIC V., "Visualizing Time: Chronometric Marking According to Aaton (1970-1987)," p. 72-76.

from the point of view of the devices “encourages us to think the question of cinematographic creation from a new point of view, by articulating the directors’ directing methods with the equipment chosen for the shooting—and therefore, with the know-how of the technicians who fully contribute to the stylistic identity of the film, thought as a collective work<sup>23</sup>.”

Such is the case of *Urban Sax in Venice* (1981) by Bénédicte Delesalle and Marie-Ange Poyet, where the performance of the Paluche and the performance of composer Gilbert Artman and his group Urban Sax merge as “the camera improvises and abolishes distances: she examines a saxophone, follows the choreographed steps of the musicians, skimming the ground, at knee height, accompanies the procession, meddles in the group, over their heads and shoulders. We get closer, in a striking proximity, we suddenly move away, surprising the group of intrigued passers-by<sup>24</sup>.” It is also via two (Aaton 16 LTR) cameras that Jean-Rouch and Raymond Depardon execute a practical exercise on the act of filming. *Ciné-portrait de Raymond Depardon par Jean Rouch et réciproquement* directed in 1983 in the Tuileries gardens is a short film which demonstrates in ten minutes a real concept of documentary films: “the exercise of reflexivity on which it is based [this ciné-portrait] particularly highlights the preponderant place of technique, in this case light and maneuverable devices developed by Jean-Pierre Beauviala and the Aaton Company<sup>25</sup>.”

A device is at the center of the Beauviala/Godard encounters: the 8.35 camera—so longed for, and then immediately rejected by the filmmaker. And yet it corresponded to a desire to “be able to make a

simple image” or “simply make an image<sup>26</sup>” by the appropriation of an unclassified object<sup>27</sup>: a prototype imagined to capture the emergence of a phenomenon before it disappears and allowing the filmmaker to do the framing himself. If only a few shots (those on-the-fly of the opening of *Passion*, 1982) remained of “this story, where the technical invention meets the formal invention,” Vincent Sorrel nevertheless notes that “we find shots of clouds, referencing those shot with an 8.35, almost from film to film, and this, throughout Godard’s work, until *Adieu au langage* (2014)<sup>28</sup>.” This prototype as well as the Delta Penelope camera, although they were never industrialized, left lasting marks in the imagination of the filmmaker. For *Route One/USA*, the two are one as Rober Kramer, with XTR Super 16 camera on his shoulder, can go out to meet his fellow citizens without having to worry about miking thanks to the synchronization provided by time marking. This freedom seems to have allowed this expatriate American to rediscover his own country with a new eye: “Cat on the shoulder, but now also a cat whose senses of sight and hearing are no longer necessarily alerted to the same stimuli, the XTR camera will contribute to the view and hearing that Robert Kramer has of these United States which he tries, after a long absence, to reconcile the pieces of at the end of the Reagan era<sup>29</sup>.” Robert Kramer’s flagship work would probably not have the definitive form we know it for without the Aaton equipment available to the filmmaker when he began filming in 1987.

It is difficult to imagine the performance of free and collective speech in *Entre les Murs* (Laurent Cantet, 2008) without the device made out of two Aaton Cantar multitrack digital recorders that allowed the simultaneous recording of sixteen tracks. This

<sup>23</sup> DE MARI A. et MASSUET J.-B., “The Study of the Aaton Collection: A Challenge to Cinema Research and a Sign of the Times,” p. 29-38.

<sup>24</sup> FLECKINGER H., “Experimenting with the Paluche: *Urban Sax in Venice* (1981)” by Bénédicte Delesalle and Marie-Ange Poyet,” p. 185.

<sup>25</sup> FIANI A., “An Exercise of Reflexivity: *Ciné-portrait of Raymond Depardon by Jean Rouch and Vice Versa*,” p. 187.

<sup>26</sup> Interview of Jean-Pierre Beauviala with Jean-Luc Godard, August 23, 1974, Aaton Collection, Cinémathèque française.

<sup>27</sup> “Genèse d’une caméra. Episode 2,” *Cahiers du cinéma*, n° 350, August 1983, p. 56.

<sup>28</sup> SORREL V., “Good-Bye Camera: The 8-35 and the Clouds of *Passion* (Jean-Luc Godard, 1982),” p. 190.

<sup>29</sup> DANIELLOU S., “The Aaton XTR on the Set of *Route One/USA* (Robert Kramer, 1989),” p. 193.



sound device coupled with three Panasonic VariCam HD cameras “allows for the responsiveness of all participants, each being able to be fully focused on the present.” Gilles Mouëllic continues by stating that “this will not to ritualize the director’s interventions desacralizes the recording and releases new energies based on permanent exchanges between the film crew and the actors, exchanges which create a form of pleasure of playing that we find throughout film<sup>30</sup>.” The portability, and the miniaturization of three Aaton Cantars with eight tracks, plus a four-track Sonosax have also allowed the live sound recording with twenty-three HF microphones of the famous music band sequence in *Saint-Merri Church* (Holly Motors, Leos Carax, 2012)<sup>31</sup>. With this device, photogenics of the image and aesthetics of reduced listening complete each other. This principle of multiple technical devices is, again, at work in *Démineurs* (Kathryn Bigelow, 2008). Here several Aaton cameras—an XTR and an A-Minima—are orchestrated to reinforce the proximity with one of the characters and emphasize the distance with others. The A-Minima is in the middle of the action while the XTR cameras are set back in an observation role. Through the immersiveness this camera allows for, the spectator and the cinematographer of the film, Barry Ackroyd, share “the way in which the character lives and experiences his job as a mine-clearer, without distance, constantly caught up in the urgency of the situations he is confronted with<sup>32</sup>.”

The last example presented in this issue, the hybrid shooting of *First Man* (Damien Chazelle, 2018) for which, among the range of cameras used, the Aaton Super 16 or 35 mm cameras occupy a prominent place. The use of analog cameras in 2018 on a Hollywood film set for a block buster movie retracing a famous period of the space race was anything but obvious. Unless you consider that the filmmaker’s interest is much more

in the intimacy of the Armstrong couple, their hearts shaken not so much by the jolts of a rocket taking off as by the vagaries of an upended life<sup>33</sup>.

Of course, these studies are limited to a few significant examples and specific cases of Aaton cameras and sound recorders. Nevertheless, these brief studies bear witness to the importance of taking devices into account in the aesthetic analysis of films. And yet, many movies still have to be examined from this point of view, because, despite the increasing interest shown by researchers and critics in the history of techniques, the separation between art and technique persists. However, the fact that artists have always used the technology of their time is a banality. The cinema, like all art, has its materials and its machinery. As Pamela Z—composer, performer, intermedial artist (performance, theater, cinema)—emphasizes, it is difficult today not to be touched by the rise of computers and digital technology, and in this regard, she is no exception:

**The computer is a tool, and I have a very strong relationship with my tools [...] I have made some of my greatest artistic advances and discoveries every time I have started using a new tool to do my job. I’ve learned over the years that one of the best ways to spur growth or a new direction in my work is to introduce a new instrument in my arsenal. I can, in fact, trace back major changes in my work throughout my life as coinciding with the introduction of these instruments. Of course, tools alone don’t make great art. I like to think that the breakthroughs I have described above stem from the combination of the effects of using the new tool and my strengths as an artist<sup>34</sup>.**

<sup>30</sup> MOUËLLIC G., “Filming the Emergence of Speech: *Entre les murs* (Laurent Cantet, 2008),” p. 195.

<sup>31</sup> MOUËLLIC G., “The Performances of the Cantar Put to the Test in a Sequence of *Holy Motors* (Leos Carax, 2012),” p. 200.

<sup>32</sup> MASSUET J.-B., “*The Hurt Locker* (Kathryn Bigelow, 2008) and the A-Minima Camera,” p. 197.

<sup>33</sup> DANIELLOU S., “Aaton Cameras on the Set of *First Man* (Damien Chazelle, 2018),” p. 202.

<sup>34</sup> Pamela Z, “Tool is a Tool,” In Judy Malloy (ed.), *Women, Art, and Technology*, Cambridge, MIT Press, 2003, pp. 348–349.

In art, nothing goes without technique. “There is no artistic object that does not depend on technique. But it is impossible to define art through technique” (Marc-Mathieu Münch, “Una cosa mentale...?”, *Le Portique*, n° 3, 1999). This is the fundamental paradox of the relationship between art and technique: *Nec tecum possum vivere nec sine te* (“I can’t live with or without you”). Paradoxically, “Aaton: A New Take on Cinema” does not dodge the question but on the contrary searches in order to overcome the sterile opposition between aesthetics and technique and accept the problematic *presence* of technique. The studies and testimonies in this number 14 of the *Cahier de l’ENS Louis-Lumière* focus essentially on Aaton’s activities in France. There is still much research to be undertaken to account for the international impact of Jean-Pierre Beauviala’s technical and industrial, as much as human and artistic, adventure.

#### GIUSY PISANO

**Giusy Pisano is a university professor at the École nationale supérieure (ENS) Louis-Lumière, researcher at IRCAV, research director at the Université Sorbonne Nouvelle Paris 3. Her latest publications : *Des ciné-goûters aux séances pour les cinéphiles. Les cinémas des Instituts français et des Alliances françaises* (dir. 2021), *Magie numérique*, (codirection 2020), *Le Panorama, un art trompeur*, (codirection 2019), *Dispositifs sonores* (codirection 2019), *Stéréoscopie et illusion*, (codirection 2018), *Machines. Magie. Media*, (co-direction 2018).**

*Giusy Pisano est professeure des Universités à l’ENS Louis-Lumière, chercheuse à l’IRCAV, directrice de recherche à l’Université Sorbonne Nouvelle Paris 3. Ses dernières publications : Des ciné-goûters aux séances pour les cinéphiles. Les cinémas des Instituts français et des Alliances françaises (dir. 2021), Magie numérique (codirection 2020), Le Panorama, un art trompeur (codirection 2019), Dispositifs sonores (codirection 2019), Stéréoscopie et illusion (codirection 2018), Machines. Magie. Médias (codirection 2018).*



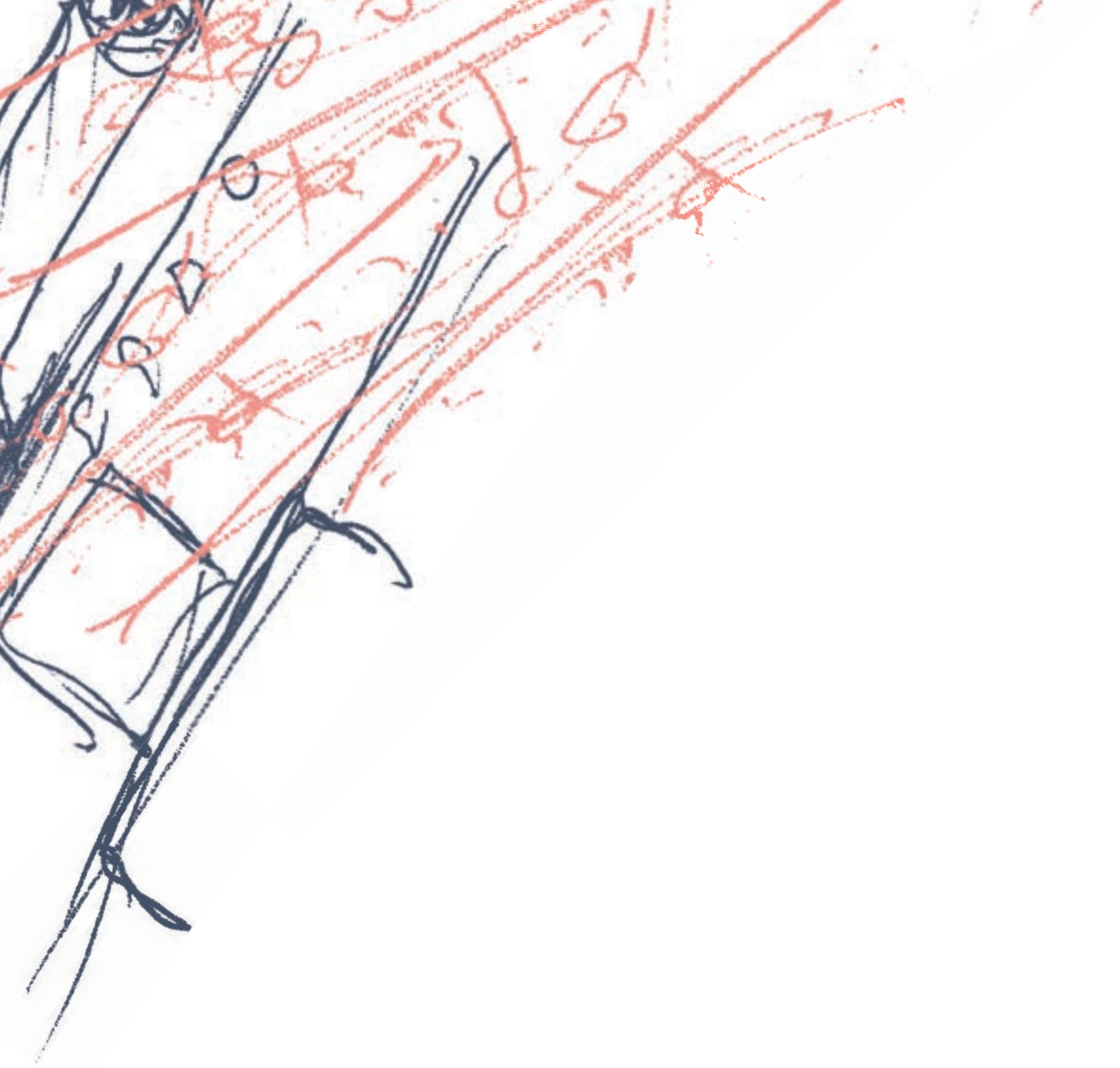

# 1. Aaton through the Archives

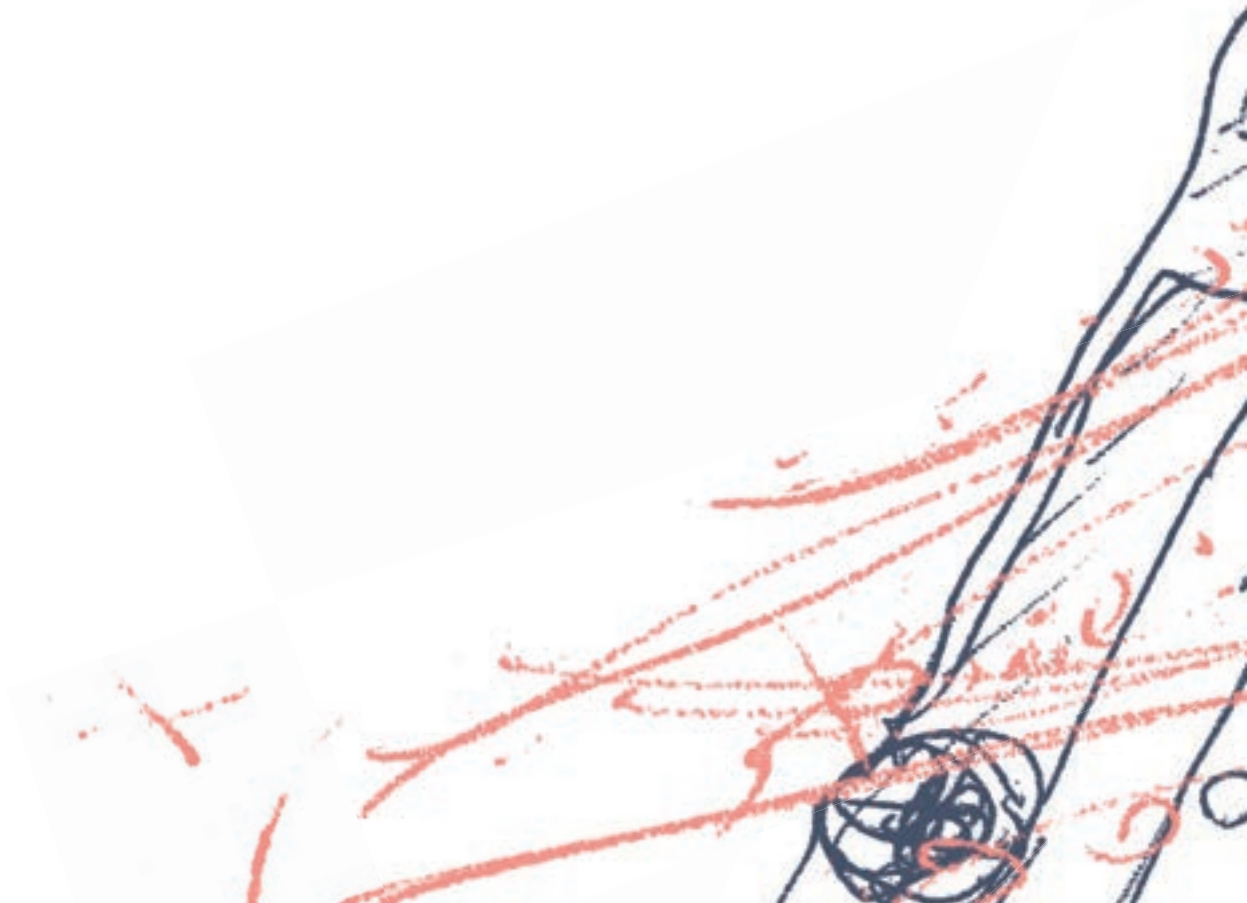



## The Commitment of the Cinémathèque française: Ten Questions for Joël Daire, Heritage Director

| Gilles Mouëllic

### Can we set some markers in the evolution of the relationship between the Cinémathèque and the conservation of devices?

Since its foundation, the Cinémathèque française has collected cinematographic equipment (pre-cinema equipment as well). Henri Langlois, in his commitment to build a Museum of Cinema, endeavored to conserve all the equipment he could acquire (for example, the famous camera made by Georges Méliès in 1896 by transforming a projector produced by Robert-William Paul, or Marey's no less famous chronophotographic gun of 1899, pieces that featured prominently at the opening of the Musée de Chaillot). The collection really became prominent in 1959, when the Cinémathèque, through André Malraux who had recently been appointed Minister of State for Cultural Affairs, was able to acquire the fabulous collection of the English technician and historian Will Day (1873-1936).

A new decisive step was taken in the early 1990s, when Dominique Païni, the new general director of the Cinémathèque, decided to recruit a young researcher specialized in the history of technology to manage the collection of equipment that was lying in Chaillot's basement. The arrival of Laurent Mannoni gave a new breath to the collection. With the help of Laure Parchomenko, he undertook a considerable work of enrichment, inventory, cleaning, restoration and cataloging of what has become, thanks to this work, the most important collection in the world

dedicated to film technology. The CNC then decided to entrust the management of its own collection to the Cinémathèque in 1997. The collection currently contains more than 5,000 machines (from the 18th century to the present day), as well as 25,000 magic lantern plates and important archives (technical plans and more than 10,000 files on manufacturers and inventors).

It has now become possible to revive research on the history of technology, a field that had been gradually abandoned since Jean Vivié's treatise. The exhibitions presented by the Cinémathèque at the Espace Electra in the years 1990/2000 (Méliès, Marey), at a time when the Musée de Chaillot had been closed after a fire, were also an important step in the rediscovery of these collections. The final stage was in 2006 when the renovated Cinémathèque opened its doors at Bercy with a permanent exhibition space named *Passion Cinéma* which features some of the treasures of the camera collection.

### When was the Conservatoire des techniques initiated and what are its missions?

The Conservatoire des techniques (Conservatory of Film Techniques) was created in 2008 within the Cinémathèque française. Its mission is to study, inventory, restore and promote the collection, to contribute to writing the technical history of cinema and to continue collecting old and recent devices.

Among its objectives The Conservatory endeavors to teach the technical history of cinema—of which most often little is known—by organizing, one Friday a month, conferences chaired by the best experts, in partnership with the Universities Paris 1-Sorbonne, Paris 3-Sorbonne Nouvelle, Paris Diderot and Paris- ▶



**The extremely rapid evolution of technologies leads to the loss of certain processes, even recent ones, considered obsolete. In October 2011, the Cinémathèque organized an international symposium on the digital revolution.**

Ouest Nanterre, the Commission supérieure technique, the Fémis, the École nationale supérieure Louis-Lumière and INA Sup.

### **Have its missions been modified by the advent of digital technology?**

Not modified in their nature, but broadened in their scope, since the advent of digital technology was immediately taken into account by the Conservatory, both in terms of collecting equipment and in terms of promotion, particularly in the context of our monthly conferences and workshops dedicated to digital technology. Today, digital technology has established itself at all levels of filmmaking. Film, used since 1889, is gradually disappearing. The extremely rapid evolution of technologies leads to the loss of certain processes, even recent ones, considered obsolete. In October 2011, the Cinémathèque organized an international symposium on the digital revolution. In 2017, it developed and adopted a charter for the submission and acquisition of digital cinema. Numerous round tables, conferences and debates have already been organized on these issues (available online on our website).

### **What are the relationships between the Conservatory and film professionals?**

First of all, there are institutional relationships. The Conservatory works in partnership with two prestigious film schools, the Fémis and the École nationale supérieure Louis-Lumière, and with the CST, the Commission supérieure technique de l'image et du son, whose archives are also housed at the Cinémathèque. These three institutions are

represented by their managing directors on the Board of Directors of the Cinémathèque and on the Scientific Council of the Conservatory.

The Conservatory has also established close relationships with the most important

professional associations such as the A.F.C. (French association of directors of photography), Les Scriptes Associés, associations of film editors, costume designers, set designers, assistant directors... And finally, on an individual basis, with many professionals not only in France but also internationally, particularly in the United States.

Thanks to this network of relationships, the Conservatory obtains many donations that constantly enrich its collections. It has also created a formidable pool of high-level speakers who have been contributing to its monthly conferences for more than 12 years.

### **What activities foster a memory of cinema as a technological art with the public?**

They are mainly of three kinds: exhibitions, conferences and symposiums, and publications. The Conservatoire des techniques has organized several temporary exhibitions that have allowed the public to discover some of its collections, in particular “*De Méliès à la 3D: la machine cinéma*” (October 2016 - January 2017). The exhibition contained unique pieces: the first cameras of Marey, Lumière and Méliès, the beautiful Technicolor of the great Hollywood classics, Jean-Luc Godard’s camera, the underwater torpedo from *Océans*, the machine from *Microcosmos*, the



luxurious and modern Panavision and the most recent digital cameras... And also: projectors of all formats, some in operation, the original loudspeaker from *Chanteur de Jazz* (1927) whose sounds could be heard, the first television (1930) and dozens of rare movies were screened—silent, sound, color, 3D movies ...—accompanied by programs explaining how these intriguing machines operate. We thus showed how techniques lead to new forms, and conversely, how aesthetic pursuit—the desire to see new images—gives birth to new devices or processes. The exhibition was accompanied by a series of screenings (*“Voyage au centre de la machine cinéma”*) and was an opportunity for an international symposium that took place within the framework of the international research partnership *Technès*. Additionally, a catalog of the exhibition was published. The example of this exhibition is a perfect illustration of the three types of actions we undertake to make the collections known to the public, often jointly: exhibitions, conferences, and publications.

### **What are the relationships between the Cinémathèque and film schools?**

As far as the Fémis is concerned, a convention with the Cinémathèque was concluded in 2015. As part of its research policy, the Fémis has developed a program to create an audiovisual archive consisting of interviews with notable film professionals, named *“Filmographies.”* It approached the Cinémathèque française for the implementation of this project. This program is based on two principles: on the one hand, the Cinémathèque and the Fémis agree each year on a list of personalities who are selected to be the subject of this research work on their profession as cinema creators and technicians; on the other hand, the students of each academic department

are responsible for conducting an interview with the personality selected in the corresponding craft. The audiovisual archives created by this work are given to the Cinémathèque, which ensures their conservation and promotion as part of its activities.

A special convention was concluded with ENS Louis-Lumière in 2018. In 2017, the Cinémathèque française was entrusted with the film archives collection of the Fondazione *“Archivio Audiovisivo del Movimento Operaio e Democratico,”* known as the “AAMOD collection,” which it now preserves and promotes. In this context, the Cinémathèque française approached the ENS Louis-Lumière to consider a collaboration for the digital preservation of this collection.

Under the terms of their agreement, and as part of its mission to safeguard and distribute film heritage, the Cinémathèque française saw to the digitization of the films in the AAMOD collection, consisting of a set of rushes shot in May 1968 in 16 mm and in black and white. The Cinémathèque provided the ENS Louis-Lumière with a copy of the digitized rushes “raw scans” and entrusted the school to carry out the films’ calibration in order for the films to be viewed in the best possible conditions. The ENS carried out this work in its calibration room, with its equipment. It entrusted the work to Quentin Bourdin, a student who graduated from the school in June 2017. The final approval of the calibration work was carried out jointly by a representative of the Cinémathèque française and a representative of ENS Louis-Lumière. An edited film, *“Vues de mai,”* was made by Quentin Bourdin and Federico Lancialonga, a guest researcher at the Cinémathèque, based on these rushes. It was screened in May 2018 at the Cinémathèque.

**What are the relationships between the Cinémathèque and academic research? Between the Conservatoire des techniques and research?**

By strengthening cooperation and partnership initiatives with the research community and Universities, the Cinémathèque française wishes on the one hand to increase scientific knowledge about the collections it preserves, and on the other hand to make its collections available to the research community, in the field of film history in general and the history of cinematographic techniques in particular.

To this end, several mechanisms have been set up to foster exchanges with the scientific community and Universities regarding our collections:

- the creation of the Conservatoire des techniques in 2008;
- the researchers' space within the Film Library;
- the creation of specific grants for young researchers (Jean-Baptiste Siegel fellowships and the establishment of the status of guest and associate researchers);
- the participation in multi-year academic research programs (such as Beauviatech);
- the co-organization and hosting of research seminars with certain universities (notably Paris 3, Paris Diderot, Paris 8, Lille 3).

The Conservatoire des techniques is a stakeholder in these projects, in particular regarding the international Technès project and the Beauviatech project.

**Is it possible to identify several fields of research to be explored from the collections of the Conservatoire des techniques?**

The fields of research that can be explored from the conservatory's collections are very vast. They cover of course the various aspects of the history of techniques (that of cameras, projection, film supports and formats, sound, television, shooting in extreme conditions, etc.), but also multiple sociological, economic and aesthetic aspects relating to cinema, its production and its crafts.

**Is there a unique story behind the donation of the Aaton collection?**

In 1999, when we noticed that the Cinémathèque française had nothing produced by Aaton—absolutely nothing, no equipment, no documents!—we sent (without much hope to tell the truth, generally these letters remain unanswered) a missive to the founder of this company, Jean-Pierre Beauviala, asking him to help us ensure that the fruits of his work could be preserved within French cinematographic collections. A few days later, on June 25th, a beautiful Aaton 35 mm camera was delivered to us from Grenoble by courier, as a first donation. It was the beginning of a long and complex adventure.

Our first visits to Grenoble were captivating. The team was terrific: Martine Bianco, Thora van Male, Pierre Michoud, Bernard Rivoire, Yves Rivière and others, all passionate, welcoming, generous—great professionals. There was a strange atmosphere in this precision instruments warholian factory, the birthplace of new machines, new images, new sounds: a crazy, atypical, electric atmosphere, both rigorous and anarchic, always on the edge. To use an Aatonian saying, “the cameras made images, and the images made cameras.”



**It is the first time in French history that the archives of a cinema equipment manufacturing company have almost entirely been preserved. The Lumière, Carpentier, Continsouza, Debrie, Coutant, Éclair, etc., archives have completely disappeared.**

The archives were scattered everywhere, on every floor, in the attic, in a barn used as a garage, in Jean-Pierre's house in Mens. He took us on a tour of his treasures, including to Mens—his house was extraordinary and perfectly reflected his personality. It was there, digging through a cardboard box that he found the body of the mythical 8-35 he had developed with Jean-Luc Godard. The famous magazine (where it says: "Jean-Luc Godard thought of you. What about you?") was missing. He found it a few months later, in another box, and donated this unique piece to us in 2008. It had been designed from 1977 onwards, not without difficulties, on the one hand by Jean-Pierre who wanted a camera as light as the field equipment Cézanne wore on his back in 1873, and on the other hand by Jean-Luc Godard who dreamed of a small but professional camera, of the Eyemo type but more advanced, ready to use instantly, and which could be stored in the front basket of a bicycle. A relationship of trust had developed; we were able to make frequent archive retrievals. We would return to Paris, a lorry full of papers that were immediately transferred into conservation boxes. Those were happy times. We had the feeling that we were saving and gathering in one place the history of a singular technical/industrial/aesthetic company.

In 2008, the Cinémathèque française decided to create the "*Conservatoire des techniques*" in order to better promote its collection of machines. The inaugural conference was marked by the presence of Jean-Pierre, who expressed himself at length on his time with Éclair during the 1960s. Subsequently, he gave several captivating and much-appreciated talks at the Conservatory, notably during a major conference

on the preservation of digital cinema (2011): he distinguished himself by throwing fragments of 35 mm film to the 400 or so delighted people who had gathered in the Salle Henri Langlois to listen to him.

**What are the characteristics of this collection, including the film fund?**

It is the first time in French history that the archives of a cinema equipment manufacturing company have almost entirely been preserved. The Lumière, Carpentier, Continsouza, Debrie, Coutant, Éclair, etc., archives have completely disappeared, only fragments remain, it is a disaster. Today, at the Cinémathèque française we have more than 700 boxes of Aaton archives, numerous shots, films (now mostly digitized, such as the 16 mm film shot during the events in Larzac in 1972), and 29 machines (collection still to be completed): a unique, complex set, open to research, complemented thanks to the generosity of the new owner of Aaton, Jacques Delacoux, who donated the whole range of Cantar devices and new cameras, including the Delta Penelope.

In 2002, a collection of more than 3,000 technical drawings were submitted. Several submissions will follow: a collection of 2,500 plans in 2003, devices and paper archives in 2008 and 2012, films in 2014. Around 2016-2017, the work of Alexia de Mari and Fabien Le Tinnier, young researchers invited to the Cinémathèque, contributed to the establishment of legal and scientific ground that allowed to work on the Aaton archives. After the death of Jean-Pierre Beauviala, the establishment of a collaboration

between the association *Les Aatoniens* (whose mission is to defend Beauviala's moral heritage) and the Cinémathèque has guaranteed easy access to the archives (particularly regarding copyright and moral rights).

Alexia de Mari, a PhD student and research engineer recruited by Beauviatech, was put in charge of a first inventory in order to allow for the archives to be accessed, according to a unique exploration system of the collection at the Cinémathèque. This inventory work began in 2015 with Fabien Le Tinnier in the context of the Jean-Baptiste Siegel scholarship. Laurent Mannoni had already done a tremendous work, extended by Alexia's, consisting in stowing the documents in "Cauchard" boxes listed on an Excel file, labeled and commented. This work is now finished. The collection's plan has been communicated to Beauviatech's researchers. From it, they can order boxes and come and consult them in the Researchers' area, by appointment.

Concerning the film collection, a workshop organized in Rennes in the presence of Marianne Bauer, an archivist at the Cinémathèque who notably works on the processing of the Aaton collection, has allowed to make a first presentation of the collection, before the acquisition of the ANR funding. The collection is made up of conservation and projection items from 1965 to 2008, digitized items or unique items, according to a thematic classification that includes technical essays, documentaries and fiction, family films, professional meetings and the life of the Aaton Company. This classification is notably accessible from the Lise database (shared with the CNC), via the site of the Archives Françaises du Film. This collection constitutes important material for a detailed archaeological study of the importance of direct cinema in the creation of

Aaton. Several films illustrate Jean-Pierre Beauviala's exchanges with filmmakers and technicians using Aaton equipment. You can also discover Aaton's teams at work in the Grenoble premises or the films made by Jean-Pierre Beauviala himself. In addition to this Aaton collection, there is an important archival collection devoted to the movie *Route One USA* (Robert Kramer, 1991), which will also be the subject of a research project: this is a real experiment showcasing the possibilities of Aaton cameras. Part of the collection has been digitized, and the rest will be digitized progressively as processing advances. Marianne Bauer regularly communicates the results to the Beauviatech team and gives researchers access to the digitized documents on request.

## The Study of the Aaton Collection: A Challenge to Cinema Research and a Sign of the Times

Alexia de Mari  
Jean-Baptiste Massuet

### Abstract

This article aims to articulate a presentation of Aaton archival fonds at the French Cinematheque, with an epistemological reflection on two levels. The first one relies on a contextualization of this fonds study: we'll see that it represents, in the "digital era", the symptom of a relatively recent conception of cinema history, leading to new approaches or new vision of this art. The second one concerns the historical perspectives that this fonds seems to call for by means of its content, at the crossroads of economics, techniques and commercial cinema history.

### Résumé

*Cet article vise à articuler une présentation du fonds d'archive de la société Aaton à la Cinémathèque française avec une réflexion épistémologique à deux niveaux. Le premier repose sur une contextualisation de l'étude de ce fonds : nous verrons qu'elle constitue, à l'ère du numérique, le symptôme d'une conception relativement récente de l'histoire du cinéma menant à de nouvelles approches ou à un nouveau regard sur cet art. Le second s'intéresse aux perspectives historiques qu'un tel fonds paraît inciter à développer par son contenu, au croisement de l'histoire économique, technique et commerciale du cinéma.*

Since its creation in 1936, the Cinémathèque française has strived to conserve films but also a large number of non-film documents linked to the history of cinema. Before and during World War II, Henri Langlois massively archived paper documents, costumes, set elements, etc. For this institution in the making, it was a question of anticipating the needs of researchers by cataloging any document that would allow retracing the history of cinema. From then on it ambitioned to address a lack in the field of history of the cinema, moving away from a historical approach based on the memory of movies, and thus on simply establishing a story<sup>1</sup>, to also take into account another history, a material one, based on primary sources, movies as well as what surrounds their production and their exploitation. This collection contains many cinematographic devices collected since its beginnings—mainly through donations—that have been promoted since 2008 through the creation of the "Conservatoire des techniques" directed by Laurent Mannoni since its creation. Its mission is: "to contribute to writing the technical history of cinema<sup>2</sup>" as well as to its teaching, while "continuing to collect old and recent devices,<sup>3</sup>" which involves relationships with film-makers and collectors, as well as with engineers or inventors at the source of certain emblematic devices.

Close to the Cinémathèque française and in regular contact with Laurent Mannoni, Jean-Pierre Beauviala, founder of the audiovisual equipment company Aaton, knew that the preservation of technical archives is one of the major challenges of the Conservatoire. Following the liquidation of Aaton in 2013, the famous inventor, concerned about ►

**1**

The story addressed here is mainly the one represented by Maurice Bardèche and Robert Brasillach (*Histoire du cinéma*, [1ère éd.], Paris, Denoël).

**2**

Cf. home page "Le Conservatoire des techniques cinématographiques," [www.cinemathequefrancaise.fr](http://www.cinemathequefrancaise.fr), URL: <https://www.cinematheque.fr/cycle/le-conservatoire-des-techniques-587.html>], consulted on September 13, 2020.

**3**

*Ibid.*

the future of his company's history, aimed to find a place capable of accommodating the archives of the company since its creation. He therefore naturally turned to the Cinémathèque française. In 2013, all the archives left the premises of Aaton in Grenoble for those of the Cinémathèque in Paris. No less than a thousand archive boxes make up this collection, not counting the cameras designed by the company<sup>4</sup> and the film collection<sup>5</sup>. As part of the TECHNÈS program and then of the Beauviatch program, supported by the National Research Agency, this archive collection is being inventoried since 2015. The first step of the Beauviatch program was to classify and index the collection, a now completed step which gives researchers a fairly precise overview of the types of documents that can be found: personal documents—photographs, letters, drawings—technical files, manufacturing plans, customer files, device prototypes, test films, etc.

It would be interesting to question how such a collection could shed new light, in a new perspective, on the history of cinema, but also to analyze what this new perspective tells us about the state of research in this field, both in terms of methodology and in terms of uncommon sources. The Aaton collection, because of the archives it contains, invites us to rethink the articulation between the history, sociology, economics, aesthetics and techniques of cinema, to the point of encouraging us to shift our gaze to the latter considering the unique context of the “digital transition.” The aim of this presentation is to shed an epistemological light on the reasons that can lead cinema researchers to take interest in this specific collection, to explain some avenues opened up by the content of the collection itself, to finally offer an example of how to approach this content, using one of the documents in the collection.

<sup>4</sup> The Cinémathèque française has a copy of each device sold by the company but also prototypes (underwater boxes, 8/35 camera of JL Godard, etc.).

<sup>5</sup> Kept in Bois-d'Arcy.

## Why the Aaton Collection?

The interest that one can show in an archival collection is very often determined by a general context within which a reflection takes place. In this sense, any research is the sign of its times and testifies to the historical stakes that make it so, whether the considerations are social, economic, political, technical, scientific, cultural, etc. To choose to study this or that collection of archives, to some extent informs in an implicit way—and sometimes unconsciously—the historian who would wish to establish what research tendencies characterize a particular period, while explaining the reasons for these orientations. De facto, the desire, the need, or the attraction that working on the archives of the Aaton Company as part of a reflection on cinema can represent, rarely escapes this observation: it is because the global epistemological context encourages us to do so today that we look at this audiovisual material manufacturing company founded in 1971 in Grenoble. This interest does not come from nowhere; it can be explained by the resurgence, around the years 2000, of problems related to cinema techniques brought by what is often called “the digital era.” With the dawn of this “new” paradigm new perspectives take shape and highlight a field of study that has rarely been explored by researchers.

To this day the question of technique has often been left aside, or at the very least been understated by cinematographic studies. The writing of the history of film techniques was primarily considered (via historians, pedagogues or popularizers, such as G.-Michel Coissac and Maurice Noverre in the years 1920-1930, Jean Vivié, engineer-technician and custodian at the Cinémathèque française up to the early 1970s, and today Laurent Mannoni) like a



**De facto, if it played a central role in the very first stories of cinema, the technical challenges rapidly yield, in the years 1920, to aesthetic considerations, when movies acquire an institutional legitimacy.**

history of the *innovations*, in the broad sense, i.e. moments of great change represented, for example, by the arrival of the synchronous sound, of color, the wide screen, light cameras, etc. Thus considered on a case-by-case basis, the technological question was probably not given, until recently, the attention which it, however, appears to demand in the field of the cinema. De facto, if it played a central role in the very first stories of cinema<sup>6</sup>, the technical challenges rapidly yield, in the years 1920, to aesthetic considerations, when movies acquire an institutional legitimacy<sup>7</sup>. But at the turn of the years 2000<sup>8</sup>, with the advent of digital cinema technology takes center stage again, eclipsing or supplementing the other factors—industrial, economic, cultural—also at work in the adoption of the new mediums. It is for this reason that the question of the technical and more particularly of the history of techniques undeniably sees renewed interest while the practices of cinema are transformed by the digital (renewal of cinema theaters, of production methods, of image and sound processing, etc.), which arouses a growing interest for the creation of a memory of previous cinematographic practices and for the study of the newly developed practices. How could we therefore still write the history of cinematographic techniques the way it was written thirty or so years ago?

It is from that perspective that new tendencies in writing the history of the cinema appear, in a fragmented way as noted by, among others, François Albera or Laurent Le Forestier. Where some will point to a possible disappearance of the history of cinema

in light of what some still call the “digital revolution,<sup>9</sup>” others don’t hesitate to notice an obvious chasm of the “territory of the history of cinema: on the one hand an aesthetic history, which parsimoniously uses what is not-movie, primarily to document the movie [...]; on the other hand a socio-cultural

history, which readily embraces within it the economic history and the technical history of cinema.<sup>10</sup>” This emergence of various “schools” is hardly surprising: it is the consequence of an opposition between a “traditional” history of cinema (the one of the birth and general evolution of cinema, based on a teleological model represented for example by the work of George Sadoul), and the one which established itself at the FIAF (International Federation of Film Archives) congress of Brighton in 1978, which we will call the “new history of cinema.” If this history, which consists in considering cinema in a “widened field,” concerns primarily cinema of the early times, its methodologies influenced the historical treatment of other periods, which Albera underlines when he describes a “renewal of knowledge” produced in various fields: “movie theaters, how spectators receive it, links between cinema and other forms of performing arts, scientific or educational cinema, mechanisms of censure, policies of states or marketing policies, technical innovations and their aesthetic effects, etc.”<sup>11</sup> This fundamentally socio-cultural history as we can see, opens a breach that researchers explore more and more, which obviously encourages widening the range of archives to spheres

<sup>6</sup> DEMENY G., *Les Origines du cinématographe*, Paris, H. Paulin, 1909.

<sup>7</sup> TURQUETY B., *Inventer le cinéma. Épistémologie : problèmes, machines*, Lausanne, L’Âge d’Homme, 2014.

<sup>8</sup> This attention to film techniques goes back to the 1990s (BELTON John, “Technology and Aesthetics off Sound Film,” In Leo BRAUDY and Marshall COHEN (dir.), *Film Theory and Criticism: Introductory Readings*, Oxford, Oxford UP, 1999, p. 376-384; Edward J. FINK, “The impact off digital video technology one production: the box off American gothic,” *Newspaper off Film and Video*, flight. 48, n° 4, Winter 1997, p. 9-19; Timothy DRUCKREY (dir.), *Electronic Culture: Technology and Visual Representation*, New York, Aperture, 1996), but studies which include this dimension in a systemic approach of cinema are rare.

<sup>9</sup> ALBERA F., « Leçons d’histoire(s) (en France) », 1895 : *Revue d’histoire du cinéma*, n°50, décembre 2006, p. 14-15.

<sup>10</sup> LE FORESTIER L., « Repenser les rapports entre histoire et théorie du cinéma : de quelques usages possibles du non-film », P. BEYLOT, I. LE CORFF et M. MARIE (dir.), *Les Images en question – Cinéma, télévision, nouvelles images : les voies de la recherche*, Bordeaux, Presses Universitaires de Bordeaux, coll. « Cinéma(s) », 2011, p. 38.

<sup>11</sup> ALBERA F., *op. cit.*, p. 15.

which exceed that of films themselves. From this widened historical setting, emerge places seemingly very detached from the considerations related to the artistry of cinema, but which are, however, filled with lessons when we choose to apprehend this medium as a socio-cultural phenomenon relying, among other things, on considerations of technical nature. And among them, we find for example the companies at the origin of the audio-visual equipment used in the manufacture of films, leading us to include engineering, mechanical and electronic work in the history of this cinema considered as a technical art.

What the digital paradigm reveals to a certain extent is that the cinema has always fundamentally been a technical art, relying on machines, whose definition can obviously be redefined by the way in which the relationship to devices evolves, in relation to a global technological context<sup>12</sup>. It no longer appears legitimate to apprehend technique solely under the angle of rupture (arrival of the sound, arrival of color, democratization of light cameras, and others): it would rather be a question of including these techniques in a broader reflection on how we think of cinema at a given time. Hence the opportunity to write a history of techniques *in use*, far from relying only on a description of the devices and mechanisms from a specific time. Aaton Company's activity, under the direction of Jean-Pierre Beauviala, happens over the years 1971 to 2013, between the revolution of the development of lightweight and synchronous cameras, promoted by the directors of the Nouvelle Vague and direct cinema, and the arrival of the digital<sup>13</sup>. If these technical transformations have effectively had an impact on filmic forms that spectators experiment with, they are nevertheless

part of a form of continuity required by filming, in particular concerning works filmed with on-board cameras<sup>14</sup>. The study of the Aaton Collection thus constitutes an ideal case which aligns with the growing interest of researchers for a history of techniques outside of the great moments of rupture, for a "normal history of techniques."<sup>15</sup> This history, which according to the magazine *1895* "still largely remains to be written [...], would require to examine the practices, the gestures, and more widely, the relationships to the body, in short, all the ways in which we make a technique our own and adopt it."<sup>16</sup> A distinctive technical imaginary of cinema takes shape here, beyond the scientific principle which determines it or of the device on which it relies, and which refers to the idea of a "technical network" in the meaning of Gilbert Simondon. According to the same article of the magazine *1895*, this network includes "the organization of all the machines [...], the places [...], the technical procedures [...], and circulation between these elements, allowing the realization of the cinematographic object and ensuring its place in culture."<sup>17</sup> In fact, the study of the cinema as "technical network" cannot brush aside what underlies this network and conditions its very existence: companies like Aaton, Flash, Arriflex, Bolex, inventors of cameras or mixing and sound recording devices, true blind spot of research in cinema, and areas of investigation opened by this new perspective on the cinema, encouraged by the upheavals linked to the digital.

The study of the Aaton collection thus reveals that perspectives on techniques have radically changed over the last years. To put it differently, technique is no longer taboo within the academic sphere, as

<sup>12</sup> It is for example the theory of André Gaudreault and Philippe Marion in their book *La fin du cinéma? Un média en crise à l'ère du numérique*, Paris, Armand Colin, 2013.

<sup>13</sup> Digital cameras appear at the end of the nineties but Aaton will be late in developing its first film digital shooting device and the company will file for bankruptcy before being able to sell it.

<sup>14</sup> Aaton manufactures light and maneuverable cameras, most of them being designed to adapt to shootings that require the use of a camera on the shoulder. The Cantar, sound recording device, will only be released in 2003 but will also proceed from a will to adapt to difficult shooting conditions where ergonomics and light weight are sought.

<sup>15</sup> TURQUETY B., "Propositions pour une histoire des techniques en cinéma," *1895*, no 82, Summer 2017, p. 13.

<sup>16</sup> Association Française de Recherche sur l'Histoire du Cinéma, "L'histoire du cinéma à l'heure du numérique," *1895*, n° 75, Spring 2015, p. 14.

<sup>17</sup> Association Française de Recherche sur l'Histoire du Cinéma, *op. cit.*, p. 16.



it echoes a distinct perception of cinema that the various upheavals related to digital technologies have contributed building. Hence the emergence and the institutionalization of modalities that take into account this mutation of cinema as an object of study, as a result of the advent of digital technology, and which makes it necessary to globally reconsider all of the history of cinema—possibly even of “pre-cinema”—through technical questions.

The study of the Aaton collection also shows the methodological approach that we described earlier, favoring a treatment similar to micro-history (restricted geographical area, relatively short chronological period) in opposition to a general history of cinema, which prevents from understanding the socio-technical circulation implications which condition the very existence of the latter, whether we choose to perceive it as a medium, an art, or a socio-cultural institution. The very nature of the documents that make up this collection allows us to take into account in a very substantive way the entire technical network that conditions cinema, from the first drawings on a sheet of paper to the final design touches of each of the building blocks of this network: correspondence of the various representatives of the company with the filmmakers or technicians informing us about their relationship to technology and devices; minutes of meetings that shed light on the inner workings of the company; invoices and account books that allow us to take into account the economic dimension related to the state of the market, to the need to build a particular device; patents and technical drawings instructing us not only on the operation of machines, but also on the differences that may exist between an invention patent and a protection patent—issues that have an impact on the life of the company and its

economic viability (without which it could no longer produce the equipment that filmmakers need for their films) etc. In that respect, the case of Aaton is all the more interesting because the company has always emphasized its relationship with users (technicians and filmmakers), which facilitates the construction of bridges between the different actors and spaces that make up the cinematic sphere as a whole, and which cannot be limited, we understand, to cinema solely considered as a group of films, as an art form, or as a cultural institution. The study of the Aaton collection encourages us to change our perspective on cinema, to include it in a broader story that sheds light, once again, on the imaginary that emerges from the discourses and the reflection on this art in the digital age, but also on the need to reexamine anew all the stages of this history.

### **What Research Avenues in Light of the Study of the Aaton Collection?**

The density of this collection makes it possible to identify several different and complementary research avenues, which contribute to drawing and understanding this new imaginary of the cinematographic thing. Without claiming to be exhaustive, we can mention three main categories that this issue of the *Cahiers Louis-Lumière* intends to pursue over all the texts that it is made up of: a technical dimension, with the presence of more or less detailed documents which allow, among other things, to approach the relationship to filmic objects in an original way; a sociological and economic dimension, related to the documents relating to the life of the company; and a communication dimension, based on advertising and others, which contributes to define the identity of the company on an already crowded market. The relationships between these three categories are close and generate ►

research avenues which, while being different, can intersect and enrich the reflections. We can even go as far as saying that the study of this collection can only rely on such intersections considering the imaginary of cinema it presents the researcher with, that a rapid tally of the research possibilities offered by its contents allows to outline.

From a technical standpoint, Aaton is a company which developed devices intended for cinema technicians; since its creation, it aimed to offer tools that answered the needs and the logic of the film crews. The technical dimension is therefore central and present in a large part of the collection: customer files tell us for example about the failures and repairs of the devices, the possible developments of the machines and allow us to understand the improvements that may have been made according to the feedback of the users<sup>18</sup>. We can therefore retrace the history of the devices through time and understand the operation of the machines as well as the way in which they were used. Precise technical documents, such as assembly plans or patents, inform us about the operation of the cameras and the work of the mechanical and electronics engineers. To better understand these documents, it is also possible to cross-reference this information with the minutes of meetings or the user manuals which make it possible to explain the purpose of certain functions and their importance.

The study of these patents, if it can appear foreign to a historical perspective, actually informs us about a certain imaginary of the technical that singles out Aaton in the audio-visual landscape of the early 1970s. Beauviala has indeed, from the very beginnings of his company, defended a singular manner of thinking cinematographic technique, by adopting a double point of view: that of the engineer and that of the scenario film-maker. The collection therefore encourages us to question the

difference—sociological, economic and technical—between a commercial approach to the technical and an approach which tries to continue to favor collaborations with technicians and film-makers, to meet artistic challenges. Of course this singular position encourages us to think the question of cinematographic creation from a new point of view, by articulating the directors' directing methods with the equipment chosen for the shooting—and therefore, with the know-how of the technicians who fully contribute to the stylistic identity of the film, thought as a collective work. We see up to what point a history of techniques in use can, enlightened by such a collection, articulate itself simultaneously with sociological considerations (relationships between technicians, filmmakers, and rental companies for example) but also with a genetics type approach.

From an economic standpoint, the funds being for the most part made up of administrative documents, its study opens the door to a history of cinematographic techniques viewed through the lens of their relationship to the audiovisual market. The balance sheets, invoices, account books and general assemblies first provide information on the internal workings of the company, which of course depends on the economic situation it finds itself in. De facto, the available budget will influence the objectives and the possible investment choices and these choices are sometimes clarified in the reports of general assemblies. This aspect also informs us about a context where economic markets have more weight than the technical experiments which are nevertheless the *raison d'être* of a company like Aaton. The supply and demand game is at the heart of the very existence of such a company and of its longevity, which informs the historian on the availability of this or that model of camera or sound recorder, for example, at any given moment of the company's history. We could thus emphasize the "improvements" made by Beauviala to the cameras like

<sup>18</sup>

In the customer files, we find exchanges between the users and the manufacturer.



**The communication of a company thus informs us as much about the identity it seeks to invent for itself, as about the reasons why it considers this identity to be the most relevant and the most legitimate.**

the ACL or Flash 16, consisting in particular of a recording of the sound on film. The history of the techniques in use indeed relies on questions of market, of which this *single system* constitutes a compelling example, clearly answering a need in the world of television reporting, while Beauviala sees no utility to it from the point of view of artistic creation (see the text of Jean-Baptiste Massuet on this subject in this issue).

It is also important to replace the numbers in their context. A company which works in the cinema sector necessarily suffers from the global financial crisis (at the beginning of the 1970s, France for example enters a period of economic stagnation, among other things linked to the oil crisis of 1973), but also depends on the evolution of the uses and on the technical mutations underway. The decisions taken by the managers will then allow to anticipate needs, to identify promising markets and to agree to change orientations according to the needs on the film sets and in post-production. These economic documents are therefore precious to “widen” the history of the cinema to these very materialistic considerations, but very important in the scope of a fundamentally technical art, in order to better understand the technological fluctuations.

From a communications standpoint, finally, the strategy of the company allows us to understand the attention paid to its public image. Advertisements in magazines, booklets intended for professionals, interviews in periodicals, the archives allow us to understand what public Aaton was targeting and how the company adapted its message to these various targets. However, what we perceive of a company like Aaton in the media is always the reflection on an issue linked to a context: the very political approach of Beauviala, for example, clearly appears as a continuation to the events of May

1968, which enabled him to found the very particular identity of Aaton—that the *Cahiers du cinéma* capture in the many interviews which they carried out with the inventor since 1974<sup>19</sup>. This outlook must nevertheless simultaneously compose with the economic health of the

company, dependent on the market phenomena which we mentioned previously. The communication of a company thus informs us as much about the identity it seeks to invent for itself, as about the reasons why it considers this identity to be the most relevant and the most legitimate considering the context in which it develops itself.

Hence these three approaches prove to be complementary when the study of the Aaton collection is envisaged as part of a broader history of cinema, and in particular as a lever to transform the way we understand and define the latter. The cinema that the Aaton Collection contributes to documenting diverges somewhat from the “traditional” description of the historians: its artistry itself depends on considerations which sometimes escape filmmakers and the cultural context in which the films are made, such as economic and scientific issues, or corporate strategies on a given market. This collection therefore offers the challenge of thinking these various perspectives collectively, as we aim to do in the following analysis of a document contained in the collection, not so much to conclude this text but to open the collection to this kind of cross analysis.

## **A Case Study at the Intersection of Three Historical Perspectives**

Let us therefore propose, in conclusion, a short case study that will exemplify the way in which the Aaton



**19**

Some examples: Alain Bergala, Jean-Jacques Henry and Serge Toubiana, “Les machines de cinéma: entretien avec Jean-Pierre Beauviala. 1,” *Cahiers du cinéma*, February 1978, n° 285, p. 9; Jean-Luc Godard and Jean-Pierre Beauviala, “Genèse d’une caméra,” *Cahiers du cinéma*, n° 348-350, June-July-August 1983; Alain Bergala, Jean-Jacques Henry and François Niney, “Stratégie/Temps: entretien avec Jean-Pierre Beauviala,” *Cahiers du cinéma*, n° 409, June 1988, p. 70-75.

collection can open to various considerations starting from documents whose levels of understanding depend on the diversity of the perspectives of the historian. We will take the case of a letter written by Michel Brault on January 29, 1986, which informs us about user feedback, dear to the Aaton Company. Michel Brault is a Canadian film director from the direct cinema movement. After reading this letter, we understand that he was asked to give feedback on a technology developed by Aaton. If it seems relatively neutral, this non-film document, studied under the angle of a “widened” history of the cinema which the epistemological context invites us to develop, looks like a multilayered object, each one of them offering a particular methodological perspective, but whose overlap is necessary to seize the way in which we can now perceive cinema, in light of such a collection of files.

The fact that the letter comes from Montreal shows that the company exported its devices across the Atlantic and that a market therefore existed over there: that of the Québécois direct cinema, born with the National Office of Film in the 1960s<sup>20</sup>, which depended on shootings with on-board cameras with reduced crews, to which the Aaton machines seemed perfectly adapted to. This letter thus informs on an economic market from which the company seemed to profit, which helps us to map the stakes of supply and demand at the international level for this type of equipment. A need arises, and it is responded to with, for example, the equipment imagined and designed by Beauviala. But, understandably, this dimension cannot be explained without taking into account the communication strategy of the company.

Indeed, we imagine, the choice of this equipment by Brault does not come out of nowhere: it was warranted by the image that Jean-Pierre Beauviala gave of himself and of his company, as being close to the directors of the Nouvelle Vague and of direct cinema. This identity

did not only rely on the cameras which it proposed in its “catalog,” and which had the appropriate characteristics for the production of documentary films (small and lightweight cameras, quiet and ergonomic), but also on the image portrayed by magazines like the *Cahiers du cinéma* which defended a certain idea of this art. The technical character of Brault’s film thus also depended on an ethical as much as an aesthetical choice, establishing an active relationship between the manufacturer of the device and the filmmaker, that Beauviala constantly sought to promote in terms of communication.

This letter shows us the importance that Aaton seemed to give to the dialogue between the users and the manufacturer, in order to validate the usefulness and the operation of the devices in the field. We understand that the equipment could be lent free of charge in exchange for feedback, in order to improve the product before a possible launch. Here, Michel Brault refers to a “marking shooting” experimented by director Annie Tresgot, and gives his report. The letter requires us to refer to Aaton’s and cinema’s history, to recognize the system of clear marking developed by the company in the 1980s, which made it possible to inscribe the date and time of the shoot on the film itself. This function aimed to, among other things, save time during editing, and, according to Jean-Pierre Beauviala, would make it possible to do without the clapperboard (see the text of Vanessa Nicolazic on this subject in this issue). But here we especially notice the premises of a debate on the use of this clear marking, drawing pure technique towards questions related to collaborative creation, essential in the production of a film. During shootings with a shoulder camera, the sound recorder and the cameraman work as a team, and Michel Brault and Annie Tresgot warn on the fact that abandoning the clap could generate the dissociation of the image crew and the sound crew. This return thus encourages the equipment

20

Cf. BOUCHARD V., *Pour un cinéma léger et synchrone! Invention d’un dispositif à l’Office national du film à Montréal*, Villeneuve-d’Ascq, Presses universitaires du Septentrion, 2012.

manufacturers to take into account, in their inventions, the organization of the film crews in order to be able to evolve practices and to offer, when possible, better suited equipment<sup>21</sup>. But beyond these technical and practical considerations, it is especially interesting to detect, behind Brault and Tresgot's feedback, a draft of reflection on the aesthetics of direct cinema. It is understood that it depends just as much on human problems—the importance of the solidarity of the film crew—than on material constraints to which the companies like Aaton seek to offer an answer through technical innovations like clear marking. This letter thus reveals an inextricable bond between the economic market and the emergence of new aesthetics, which fundamentally depend on technological issues linked to these companies, however, very often not spoken of in the context of research in cinema.

These three perspectives work together when we consider cinema as an art based on technique and machines: the latter are not “a given,” they proceed at the same time from questions linked to markets, communication strategies, considerations related to the engineering and the practice of film—but especially from the perspective which we choose to adopt here on cinema. We have to recognize that “putting on the glasses” of commercial engineering, to borrow Andre Gaudreault and Philippe Marion's expression<sup>22</sup>, the definition which one attaches to cinema seems to be open to new fields of studies. It is not only about an art anymore, an industry, or even a cultural institution, but rather about a kind of socio-cultural network based on technical considerations. The challenge represented by the Aaton collection is without a doubt to manage to enlighten the history of cinema and of the films that constitute it in light of this renewed definition (and necessarily partial) that the technical question carries with it. Because as we see,

this type of company is involved, by the means of its strategic choices or simply by its technological choices, in the existence of certain aesthetic movements just as much as the stylistic inventions of certain filmmakers. Which underlines the importance of a taking these collections into account to better understand the way in which cinematographic production constantly reinvents itself, as technologies adapt to the needs or desires of the creators. An opportunity, perhaps, to add a stone to the constantly being built true *aesthetic history* of cinema, a long-running epistemological question that comes and goes from one era to the next, and which seems to take notice, here, of a constantly evolving field of study in which the technological element plays an important part, long ignored by researchers.

Obviously, the study of the Aaton collection is not limited to a case study and opens perspectives for several fields for research. As a human-sized company, the Aaton collection offers the opportunity to understand for example the mechanisms which govern a company in this business. And in addition, the frequent exchanges between users and manufacturers inform us on the impact that technologies can have on cinematographic practices—it is possible to question the relationship between these technological developments and the aesthetics of films—while inviting us to reconsider a history of the crafts, for which practical considerations influence the mechanisms and choices which result in obtaining a new machine (technology, usage, economy). In light of such a collection, let us venture that cinema research will engage in a better understanding of the specificities of this art observed here by the prism of the technical, whose aesthetics and history always fit in a broader context which regularly determines, even in an implicit way, the whys and wherefores. ►

<sup>21</sup>

If clear marking seems a relevant technique for post-production work, in order to realize savings in film and to free the users, this technique would need to be used carefully if one removes the use of the clapperboard which federates the crews at the beginning of shoot. During interviews carried out with Jean-Pierre Beauviala between 2015 and 2018, he talked about this technique and about the way he had presented it to technicians. According to him, he should not have proposed to abandon the clapperboard which was anchored in the practices of filmmaking and had another goal than that of the synchronization of the machines: that to unite all the crews during shootings which concentrated on the take at the same time.

<sup>22</sup>

Cf. GAUDREULT A. and MARION P., *La Fin du cinéma? Un média en crise à l'ère du numérique*, Paris, Armand Colin, 2013.

#### ALEXIA DE MARI AND JEAN-BAPTISTE MASSUET

Alexia de Mari is a doctoral student in film studies, enrolled under the joint supervision of Ms Kira Kitsopanidou and Mr Guillaume Soulez, at the Université Sorbonne Nouvelle Paris 3. Her thesis topic is the interactions between the process of creating technical objects and their uses, through the case of the first Aaton cameras. She is a research engineer in the ANR Beauviatech program, lecturer and researcher at the 3IS School and lecturer at the University Sorbonne Nouvelle Paris 3.

*Alexia de Mari est doctorante en études cinématographiques, inscrite sous la direction conjointe de Madame Kira Kitsopanidou et Monsieur Guillaume Soulez, à l'Université Sorbonne Nouvelle Paris 3. Son sujet de thèse porte sur les interactions entre le processus de création des objets techniques et leurs utilisations, à travers le cas des premières caméras Aaton. Elle est ingénieure d'étude dans le cadre du programme ANR Beauviatech, chargée de cours et chercheuse à l'école 3IS et chargée de cours à l'Université Sorbonne Nouvelle Paris 3.*

Jean-Baptiste Massuet is lecturer at the University of Rennes 2, author of the book *Le Dessin animé au pays du film - Quand l'animation graphique rencontre le cinéma en prises de vues réelles* (PUR, 2017) and co-director of the books *Point de vue et point d'écoute au cinéma : approches techniques* (PUR, 2017) and *La Capture de mouvement ou le modelage de l'invisible* (PUR, 2014). He is also co-bearer, with Gilles Mouëllic, of the ANR BEAUVIATECH project, and has several publications to his credit, in collective works and journals.

*Jean-Baptiste Massuet est maître de conférences à l'université Rennes 2, auteur de l'ouvrage Le Dessin animé au pays du film – Quand l'animation graphique rencontre le cinéma en prises de vues réelles (PUR, 2017) et co-directeur des ouvrages Point de vue et point d'écoute au cinéma : approches techniques (PUR, 2017) et La Capture de mouvement ou le modelage de l'invisible (PUR, 2014). Il est également co-porteur, avec Gilles Mouëllic, du projet ANR BEAUVIATECH, et a à son actif plusieurs publications, au sein d'ouvrages collectifs et de revues.*

## The Aaton Film Collection: Technical Tests and Slices of Life

Marianne Bauer  
Simon Daniellou

### Abstract :

Through its originality and diversity, the test film collection registered at the Cinémathèque française by Jean-Pierre Beauviala encourages researchers to cross disciplines as they make their way through film documents that are often hybrid in nature: technical tests mix with home movies, professional relationships mingle with long-term friendships. Several reels in the collection thus bear witness to the way in which the constant desire of the engineer to ensure the sustainability and the practicality of his devices is also an ethical matter. In addition to allowing us to study in detail the main inventions of the Grenoble-based firm, in particular concerning the relationship between shooting and sound recording, and also the technical, economic and aesthetic issues regarding film formats, these reels show glimpses of lives that say a lot about the men and women who made Aaton's heartbeat and who participated in the technological developments of the past fifty years.

### Résumé

*Par son originalité et sa diversité, le fonds film déposé à la Cinémathèque française par Jean-Pierre Beauviala incite les chercheurs à croiser les approches tandis qu'ils se fraient un chemin dans des documents filmiques de nature bien souvent hybride, les essais techniques se mêlant aux films de famille, les relations professionnelles aux amitiés au long cours. Plusieurs bobines du fonds témoignent ainsi en creux de la façon dont la constante volonté chez l'ingénieur*

*d'inscrire dans le temps ses appareils et d'en assurer la praticité relève aussi d'un véritable souci éthique. En plus de permettre de revenir en détail sur des inventions phares de la firme grenobloise, en particulier concernant les rapports entre les prises de vues et de sons et les enjeux techniques, économiques et esthétiques liés aux formats de pellicule, ces bobines recèlent des tranches de vie qui disent aussi beaucoup des hommes et des femmes ayant fait battre le cœur d'Aaton et plus largement participé aux évolutions technologiques des cinquante dernières années.*

In 2013, Jean-Pierre Beauviala entrusts approximately 170 recorded reels to the Cinémathèque française, both images and sounds<sup>1</sup>. Each reel tells a part of Aaton's adventure, but also a more intimate story, private life and professional life very often mixing with this engineer who anchored his inventions in the contingencies of reality. The elements in this collection span a period from 1965 to 2008 approximately. The set consists of numerous negatives (more than half of it), unique elements on reversal film, work elements (mostly silent), rushes, a few release copies, magnetic audio tapes and, and trims, mostly shot in 16 mm, Super 16 and 35 mm format. In order to safeguard this collection and make it available to researchers, the Cinémathèque française started to digitalize it in October 2019<sup>2</sup>. At the laboratory of the *Centre national du cinéma et de l'image animée*, the elements are catalogued in the "Lise" database. The technical tests make up most of the collection, but we also find fictions and documentaries (sometimes incomplete), home movies, or images which show professional meetings or activities within the Aaton Company. In particular, the borders are not airtight and sometimes researchers of the program can divert elements of the collection from their original function, since by ►

<sup>1</sup> We thank Laurent Mannoni, scientific director of heritage of the Cinémathèque française, and Laure Parchomenko, in charge of the collections of devices of the Cinémathèque française, for their support and for making the archives available.

<sup>2</sup> We thank Pedro Marques, verifier and scan technician at the Cinémathèque française, in charge of the digitalization, synchronization, editing and calibration work.

carrying out his technical tests in the buildings of Aaton or at home, Jean-Pierre Beauviala filmed places, collaborators, relatives. As of its beginnings in the middle of the 1960s, the first tests which he shoots in black and white with standard Arriflex 16 mm camera are done in a private context, in Grenoble and close by, in particular in the village of Mens where he is building his house. The limits between categories are thus fuzzy and home movies can be regarded as technical tests as well, this porosity testifying no less to the concerns of the engineer. Thus it is of "*Film de famille Beauviala n° 5*" where one can see Beauviala bare chest filming a television test pattern next to a record player while catching his reflection in a mirror. In its way, this test, carried out around 1969, gathers within the same frame the principal components of his work to come during the next decades: sound, the image and the body of the operator, conveyors of a singular point of view and point of listening, in the service of which a device is designed.

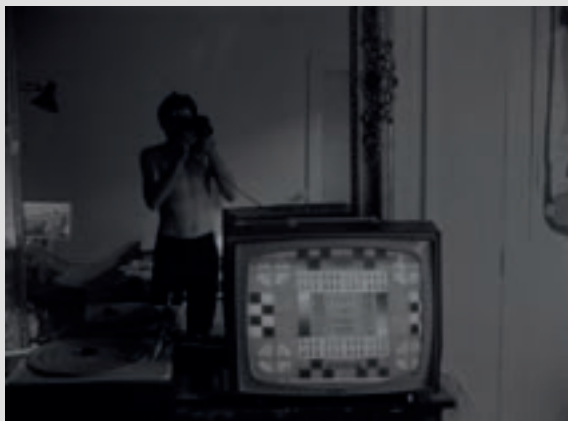

Beauviala family movie n°5 - Fonds Aaton/La Cinémathèque française

The technical tests (stillness<sup>3</sup>, *aatonite*<sup>4</sup>, *telecine transfer evaluation film*<sup>5</sup>, etc.) which constitute this collection also make it possible to measure the company's influence, in particular by identifying the diffusion of its inventions throughout the world. The indications that appear in it invite us to identify the camera numbers (e.g. B46, C374, C551) which can then be associated with a customer file using the paper archives to uncover the date of sale, revision, etc. More broadly, these tests shed light on Aaton's economic logic which is based on building customer loyalty through an individualized after-sales service and, more generally, a pursuit of durability of devices whose improvement is intended to be incremental. In contrast with the programmed obsolescence that dominates today, the guideline imposed by Beauviala on his engineers assumes that each new invention should be compatible with previous devices ("retro-part" and "retro-tool" principles). For the engineer, it is also a question of allowing operators, who in the past sometimes bought their own, often expensive cameras, to "update" their equipment by acquiring only some of the new parts designed by Aaton, to adapt them without difficulty to their older equipment. What's more, these technical tests are invaluable documents giving researchers the opportunity to conduct a genuine archeological research of the firm's inventions and more generally of the audiovisual engineering of the last fifty years. Thus, the study of these technical tests found in the film collection particularly highlights two main grooves tirelessly dug by Beauviala and his teams, that of the roll film format and that of the relationship between sound and images.

**3** Stillness corresponds to the correct positioning of each photogram by the drive mechanism. Cf. "Les essais caméra," *film-making.com*, a site of the ARSCIPRO association, <http://www.film-making.com/cybtrp11.php>, last consultation on September 15, 2020.

**4** Reflective paint with which the frames of the focusing screens are made, allowing to illuminate a specific frame with an adjustable intensity so as to facilitate the operator's work in low light situations. See the manuals of the XTRprod, Xterà or Penelope cameras available online.

**5** Calibration system for telecinema developed by Kodak in Chalon-sur-Saône and Aaton that allows chief operators to quantify the video distortion introduced on their film images. Cf. EDE F. and ROTH L., "L'invention de la charte," *Cahiers du cinéma*, n° 503, January 1996, p. 95.



## Technical Tests 1: The Quest for Formats Adapted to Uses

The first test of the film collection shot with a prototype of the firm's first camera, the Aaton 7 in Super 16 format, dates back to 1972. It documents a meeting between Jean-Pierre Beauviala and Swedish cinematographer Rune Ericson in front of the Stockholm Cinemathèque, in the presence of photographer Anders Petersen. Three years earlier, Ericson had developed the Super 16 format by modifying an Éclair 16 camera<sup>6</sup>, in order to obtain an image much bigger than that of the standard 16 mm (+40%), for an image ratio of 1.66:1, which is better suited to 35 mm blow up, but also subsequently to 16:9 transfer (i.e. a ratio of 1.78:1). Beauviala was one of the first to foresee the future use of this ratio on television ("HDTV"), with Aaton selling several prototypes of the Aaton 7 to French television as early as Easter 1973<sup>7</sup>, even if it took a few years for the camera to be actually marketed. In order to reduce costs for filmmakers wishing to see their works broadcast in 35 mm without being able to pay for it, Aaton industrialized this filming format: its cameras will be designed for television and cinema professionals<sup>8</sup>, to be used in 16 mm formats such as Super 16.

Although Beauviala's work during the 1970s and 1980s focused strongly on the question of time marking, the engineer did not forget the question of the formats to which he regularly returned, particularly during the following decade, with "High Definition" television in mind. In particular, he sought to push the format limits imposed by film manufacturers, reconsidering image space and frame ratios in order to optimize the cinematic experience



Aaton : Jean-Pierre Beauviala meets Rune Ericson (left) in Sweden - Fonds Aaton/La Cinémathèque française

and control costs. The film collection thus contains two fragments shot in 1993 in Super 9.5 format with a modified Beaulieu 9.5 camera. It was in 1991 that the Société d'exploitation du film (SEF) founded by Paul Bigou placed an order with Aaton for a prototype 9.5 mm camera that Beauviala proposed to align with the 16:9 ratio that was then on the horizon for HDTV. This required further rationalization of three part division of the 35 mm strip, which, with the traditional 9.5 mm process, resulted in an unusable 6.5 mm waste. Beauviala aimed for a width of 11.66 mm (11 2/3), for an image ratio finally higher than that of 16 mm<sup>9</sup>. But this project of a mini-camera Aaton 11 2/3 or Aaton IC 12 will not finally succeed, the Beaulieu, Bolex 16 or Éclair ACL, Pathé Webo and Eiki (16 mm or 9.5 mm) cameras and projectors could, however, be adapted to the Super 9.5 format. This work on cinematographic film formats with the best possible quality/price ratio continued to occupy Jean-Pierre Beauviala, who notably published an article on Super 16/9<sup>10</sup> with Marie Archambault, assistant director<sup>11</sup>, a format defended in 1993 by Aaton, Panavision and Arriflex in the context of a 1.78:1 standard.

<sup>6</sup> ERICSON R., "Why Shoot in Super-16," *American Cinematographer*, vol. 62, n° 2, February 1981, p. 162.

<sup>7</sup> BERGALA A., HENRY J.-J. and TOUBIANA S., "La sortie des usines Aaton. Interview with Jean-Pierre Beauviala. 2," *Cahiers du cinéma*, n° 286, March 1978, p. 6.

<sup>8</sup> Television is Aaton's primary market, see NICOLAZIC V. and SORREL V., "Main, épaule ou les creux de l'identité: une archéologie de l'Aaton 7," R.BEGIN, G.MOUËLLIC and T. CARRIER-LAFLEUR (dir.), *Un cinéma en mouvement: portabilité des appareils et formes filmiques*, Presses universitaires de Montréal, 2021.

<sup>9</sup> In 1933, Kodak adopted a 1.37:1 ratio for its 16 mm format to compete with Pathé's 9.5mm format, invented in 1922. Cf. *Objectif 9,5*, n° 7, juillet 1993, p. 9.

<sup>10</sup> BEAUVIALA J.-P. and ARCHAMBAULT M., "Formats d'hier et format [sic] d'aujourd'hui. Quels cadres choisir?," *Le Technicien du film & vidéo*, n° 432, 1994, p. 25-33.

<sup>11</sup> She is notably assistant to the director Claude Mouriéras for the film *Montalvo et l'enfant* (1989) based on a ballet by Jean-Claude Gallotta. In July 1993, she was responsible for the editing and layout of issue 7 of the journal *Objectif 9,5*, for which she wrote the editorial and in which she conducted an interview with Jean Rouch.

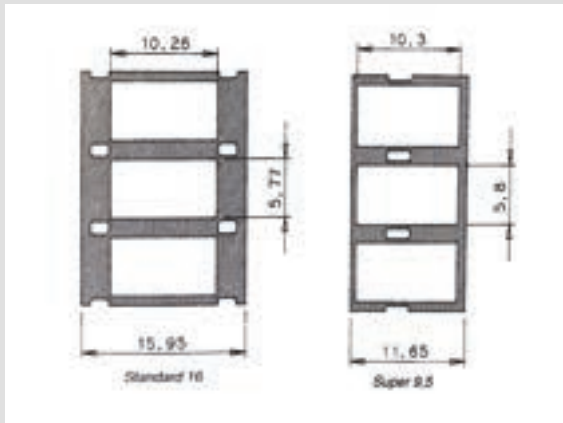

Jean-Pierre Beauviala holding a prototype of Aaton 11 2/3 in *Objectif 9,5*, n°5, « Du 9,5 au Super 9,5 », p. 4-5

Beauviala's research also looked into professional formats. With Ericson, he had been advocating since the mid-1980s the Super-35 in 3 perforations, then the 2-perf scope format (or Scope 2Perfos). This involved using all the space available on the film, including the space normally reserved for the sound track, for shooting with spherical optics requiring less lighting and offering, especially for the 2-perf format, a greater

depth of field. In addition, with these formats, film consumption was reduced by 25-50%, while the camera, which was quieter, consumed less energy. However, these shooting formats were not intended for distribution: there was no longer any continuity between the shooting medium and the distribution medium. The 3-perf format was in fact intended for video transfer or for transfer in 4 perforations by optical transfer<sup>12</sup> for theatrical distribution. The film collection contains a test shot in 3 perforations in 1993—probably with a prototype of the Aaton 35 II camera—and a 2006 test shot in 2 perforations with a modified Aaton 35 camera, in the company's own premises. It is with this equipment directly offering an image in scope format<sup>13</sup>



2-perf scope test - Fonds Aaton/La Cinémathèque française

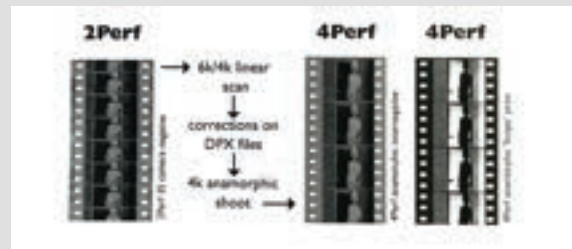

2-perf scope test - Fonds Aaton/La Cinémathèque française

12

In the late 1990s, some laboratories were equipped with a 3-perf negative contact printer to obtain a 3-perf master positive and an anamorphic printer to obtain a 4-perf inter-negative. The images obtained in 4-perf are in scope format. Aaton Collection, Conservatoire des techniques de la Cinémathèque française. Today, film images go through a digital intermediary, but if a 1.85:1 aspect ratio can be achieved in post-production, this results in a loss at the top and bottom of the image, whereas the 1.78:1 of 3-perf corresponds to the format of 16:9 television.

13

The negative is scanned and, after post-production, a return to film is made by enlarging and anamorphizing the images. This gives you a 4-perf copy in scope format. It is also possible to consider distribution in 1.78:1 and 1.85:1 formats, but with a loss at the edges of the image.

that Raymond Depardon shot *La Vie moderne* in 2008<sup>14</sup>. The Aaton Penelope camera, which will be marketed the same year<sup>15</sup>, was designed for 2 or 3 perforations shootings only, as the conversion from one format to the other could be done quickly.

Around 1994 in Mens, Beauviala and Archambault also carried out several tests in “shifted images” that can be accessed in the collection. It is a patented format for users of Super 16 format reversal film, which can be directly projected. The purpose of this process, called 16 ID, is to improve the projection quality and reduce the fragility of the film by slightly shifting the interimage so that it is not at the same level as the perforations. This reduces the stress on the glues and makes them less visible. The film collection also contains a test on stillness made the same year in 16 ID format with the LTR B46 camera of Alain Mahuzier, author of the “*Connaissance du monde*” series of film lectures. However, in a letter addressed to Aaton<sup>16</sup> in 1994, the latter requested the transformation of its 16 ID camera to adapt it to the standard 16 mm format in order to be able to edit with older images those shot with this camera. The Aaton test collection shows that, despite conclusive tests, the sustainability of a process is highly dependent on a widespread implementation at the right time.

This quest, which is reflected in the essays preserved in the collection, is also that of the standardization of the production chain desired by Beauviala in order to facilitate adaptation to different modes of distribution, while complying with quality standards (such as 16/9° for example), but these strategic choices must also make it possible to ensure the preservation of audiovisual elements, starting from what already exists and favoring the most universal formats, whose very use guarantees their inclusion in the long term.

<sup>14</sup> See the text devoted to the film in this issue, p. 202.

<sup>15</sup> Cf. the text devoted to the film *First Man* (Damien Chazelle, 2018) in this issue.



Aaton : first shifted image films - Fonds Aaton/La Cinémathèque française

Beauviala’s long-running reflection on film formats was thus guided by a twofold concern for practicality and economy, in the service of the production and distribution of a certain type of production whose aesthetic concerns the engineer also shared. In these tests, a Beauviala “director” takes shape, who knows what is important for a filmmaker, a cameraman and therefore a camera: the management of depth of field, luminosity, the relationship of the image taker to space and to the filmed object (impact of ergonomics on the cameraman’s movements, panoramic versus traveling, 45° viewfinder for low-angle shooting and management of frame shaking) and the respective freedom between the latter and the sound recorder. ►

<sup>16</sup> Aaton Collection, Conservatoire des techniques de la Cinémathèque française.

## Technical Tests 2: The Long History of Time Marking

The sound/image ratios are indeed another very important part of Aaton's tests in the film collection. They were approached by Beauviala according to two diametrically opposed approaches: one imposed by the orders he received at the beginning, practically against his deepest will, the other much more in line with his conception of audiovisual creation. At the heart of his thinking, the question of synchronization—and therefore regularity—between sound and image led him to design an electronic clock regulation circuit for the motor of the Arriflex 16 ST camera, which he presented to the Éclair company in 1966<sup>17</sup>. Three years later he carried out several tests, firstly with the prototype of the ACL camera<sup>18</sup> for which he developed a motor<sup>19</sup> and secondly with the Éclair 16 camera for the "Single System."<sup>20</sup> Éclair asked him to develop a device for his 16 mm camera that would allow a single person to take the sound recording while shooting. His friend Jean-Philippe Carson informed him at the time that the American market in particular was asking for such a process, known as "Single System," for reporting (news) purposes. As Beauviala himself explained in a "blackboard" demonstration of the system recorded by a prototype, the challenge was as follows: most cameras give the film an intermittent motion at the film gate, but to record or play back sound on a medium, it has to move as regularly as possible in front of the recording/playback head<sup>20</sup>. The solution proposed by Beauviala was the digitization of sound, which he obtained by developing the first digital sound recorder whose electronic circuit design was filmed in two of the six preserved reversal film test tapes. The sound was thus stored momentarily in a memory located in a separate box attached to

the reporter's belt, while a roller, attached to a very precise tachometric wheel, was integrated into the camera's magazine. The wheel measured the instantaneous film speed and sent this information to the electronic device. A stable and good quality sound could thus be transmitted from the memory at the same speed as the image and then recorded on a magnetic tape lying on the film's sleeve.



Beauviala family movie n°6 : prototype of the ACL camera - Fonds Aaton/La Cinémathèque française

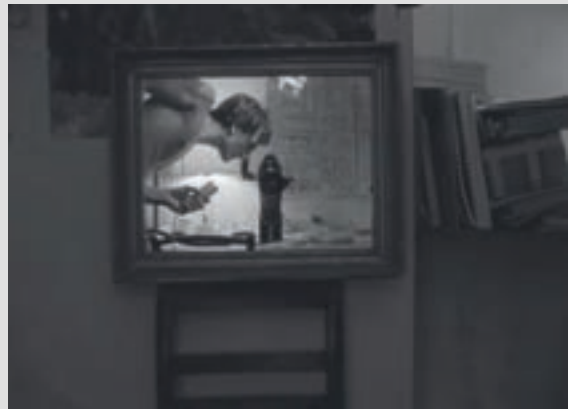

Single System 1 tests - Fonds Aaton/La Cinémathèque française

<sup>17</sup> SORREL V., "L'invention de la caméra Éclair 16: du direct au synchrone," 1895 : *Revue d'histoire du cinéma*, n° 82, Summer 2017, p. 127.

<sup>18</sup> We would like to thank Vincent Sorrel and Vanessa Nicolazic for their generous assistance in identifying the equipment in the tests in question.

<sup>19</sup> SORREL V., "L'invention de la caméra Éclair 16 : du direct au synchrone," art. cit., p. 128.

<sup>20</sup> Aaton Collection, Conservatoire des techniques de la Cinémathèque française.



If the “single system” principle had become the standard for all camcorders (analog and digital) and if it allowed Beauviala to experiment with the digitization of the sound signal, his concerns were quite different. Indeed, very early on he was interested in the idea of being able to record concomitant sounds as part of a film project on Grenoble’s urban planning, and thought about a device in which the sound recording was independent of the filming. It was therefore a question of dispensing with the cable linking camera(s) and tape recorder(s)<sup>21</sup>, the synchronization of which must nevertheless be ensured, a task which will be at the center of Aaton’s work even before its creation, some tests dating back to 1967. Beauviala’s answer came in the form of time marking, for which he and his collaborators at Aaton—several of whom he met at Éclair, such as François Weulersse and the mechanical specialists Jacques Lecoœur and Robert Leroux—developed several accessories for cameras and tape recorders, as well as post-production machines: in addition to the quartz engine<sup>22</sup>, a master clock called Origin C—which we see handled by Rune Ericson in a roll shot by Beauviala in Stockholm in 1981—, a transcoder, and the Adage printer.

The first eye-readable clear marking system was introduced in the late 1970s and integrated into the Aaton 7 LTR camera (Option T). In the camera there is a letter and number display device<sup>23</sup> and in the sound recorder there is a modulator that records coded signals<sup>24</sup>. This marking contains information relating to the shooting: the date, the exact time, a production number, as well as an equipment number taken automatically from the camera and the tape recorder. The image and sound tracks contain these indications at regular intervals (every second).

*Piparsod II* (1981), a documentary by Saeed Akhtar Mirza, was the first film shot with Aaton’s complete clear marking system. According to a company advertisement, the editing was completed by Elisabeth Kapnist in just nine days. Raymond Depardon used clear marking for the shooting of *Faits divers* (1983). He reported that it was a way of identifying his takes without wasting too much time, and that “anyone can do the identification and syncing.” For Depardon, “marking is actually a ▶

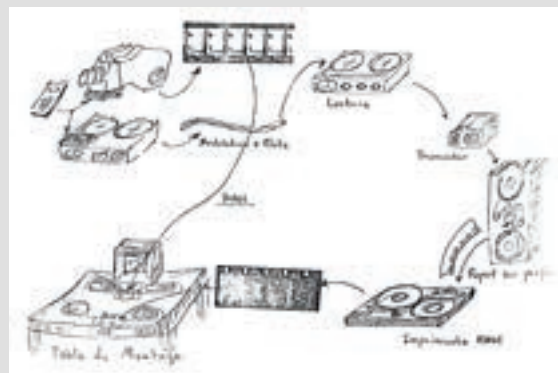

**Analog assembly line - Fonds Aaton/Conservatoire des techniques de la Cinémathèque française**



**The Origin C at a demonstration of the Aaton code in Stockholm (1981) - Fonds Aaton/La Cinémathèque française**

**21** In addition to removing the clap that may interfere with shooting.

**22** The first quartz watch of the Japanese brand Seiko was marketed in 1969.

**23** A microprocessor activates light-emitting diodes that write the time code during the transport of the film.

**24** The modulator records encoded signals on the sync track of the magnetic tape which can then be translated in time and displayed when replayed.

revolution: upstream, it changes the way of shooting, the relationship between technicians, the approach to the subject; downstream, it gives the editors more freedom.<sup>25</sup> But Jean-Pierre Beauviala was already anticipating the change in editing practices. As the post-production chain evolved—Rank Cintel presented the first telecine in 1981—Aaton adapted its marking of time. A marking in binary language<sup>26</sup> was thus added so that it could be read by a telecine. The matrix code, known as the Aaton Code, contained the same information as the clear marking and alternated with the latter on the film sleeve. After the

mid 1980s, this dual time marking was incorporated into the new Aaton XTR cameras, allowing Robert Kramer to edit the 65 hours of footage from *Route One/USA*<sup>27</sup>, for example, although a reimpression of an “Adage” coding for naked eye identification on the soundtracks was still necessary at the time. For this post-production phase, a new accessory was developed, the Linker. Consisting of a reading head installed on the telecine to read the matrices, the Linker slaved the telecine and the Nagra (for playback) at the time of the cinema/video transfer so that the images and sounds were synchronously transferred to the video tape. The video recorder was also adapted to be able to read and then display the Aaton Code on the screen.



Marking test using a 16-segment display - Fonds Aaton/La Cinémathèque française



Clear marking - Fonds Aaton/La Cinémathèque française

Binary marking, which saves 25-30% of time during the telecine stage, is more successful than clear marking, especially in the United States. Panavision enters into licensing agreements with Aaton. The two companies join forces to promote the use of the Aaton Code and to adapt time marking for Aaton and Panavision cameras in 35 mm format, with several tests to keep a record of this collaboration. A presentation of the film-video workflow under Aaton Code<sup>28</sup> took place at the Centrimage laboratory in Paris in 1995, with the participation of Renato Berta, Raymond Depardon and Claudine Nougaret<sup>29</sup>. The idea was to “see the video film with time marking workflow running in real time.” The shooting of a rehearsal of a group of musicians takes place in Super 16 with two Aaton XTRprod cameras, followed by development and video transfer with automatic synchronous sound. The video-synchronous rushes are viewed before being digitized to disk and then edited on Avid Film Composer. Two reels from the

<sup>25</sup> DE LATOUR E., “Le marquage du vent,” *Cahiers du cinéma* n° 409, June 1988, p. 76-77.

<sup>26</sup> It consists of a matrix of 7x13 dots which correspond to 91 “optical bits” or approximately 22 digits.

<sup>27</sup> Cf. the text devoted to the film in this issue.

<sup>28</sup> Aaton Collection, Conservatoire des techniques de la Cinémathèque française.

<sup>29</sup> In *Citizen Beauviala*, a France Culture program produced in 2007 by Yaël Mandelbaum and Julien Marrant, Claudine Nougaret recalls having defended Aaton’s time marking, which had difficulty being adopted. *Délits flagrants* (1994) by Depardon would not, in her opinion, have been possible without the Aaton Code. [<https://www.franceculture.fr/emissions/les-nuits-de-france-culture/surpris-par-la-nuit-jean-pierre-beauviala-12-1ere-diffusion-02102007>]



**Binary marking - Fonds Aaton/La Cinémathèque française**



**Reading head on the telecine - Fonds Aaton/La Cinémathèque française**

film collection document a similar event organized in 1996 in Los Angeles by “Aaton des autres inc.”—Aaton’s distributor based for a time in Burbank, California—and numerous partners<sup>30</sup>, with the recording of a concert by the group *Brothers* by three 35 mm cameras (a Pana 336 G II and two Aaton 35 III)<sup>31</sup>.

The film collection keeps about thirty tests (on about 65 reels) on film, which allows to compile a precise chronology of the evolution of the Aaton time marking. It is more broadly part of a history of “direct cinema” that various time-marking techniques pre-existing or contemporary to the one

of the Grenoble-based company are going through, experimented with by the IRT (Institut für Rundfunk Technik) in Germany, the TDF (Télé-Diffusion de France), and the NFB in Canada (with the *Time Index System*), the Society of Motion Picture and Television Engineers in the United States (with the SMPTE code), while the search for synchronization without *pilot tone* (piloton) intersects Pennebaker and the Maysles research (with the use as early as 1960 of an Accutron tuning fork watch of the American brand Bulova in an Auricon camera), or even of Simon Mooris, who is said to have done the same thing in the United States for *Weddings and Babies* as early as 1958.

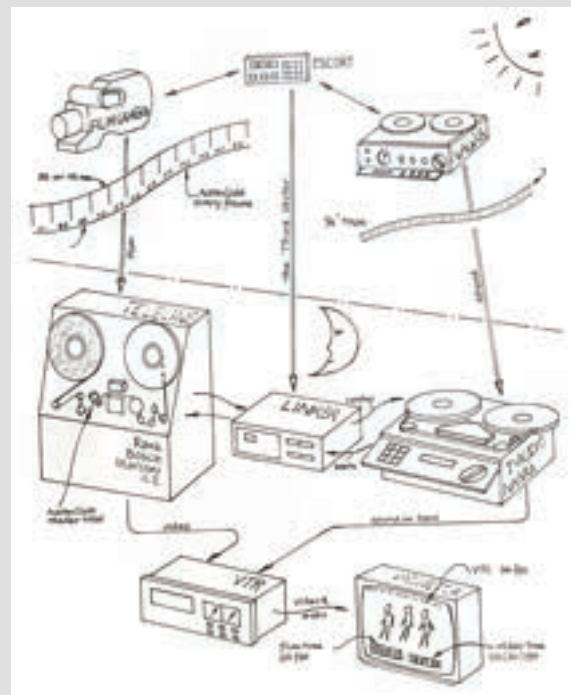

**Virtual assembly line - Fonds Aaton/Conservatoire des techniques de la Cinémathèque française**

<sup>30</sup> Avid Technologies, Deluxe Labs, Eastman Kodak, Panavision and Rank Cintel.

<sup>31</sup> The cameramen Tom Sigel, Mike Thomas and Tony Nako took part in this event, the sound recording was done by Dave Missal.

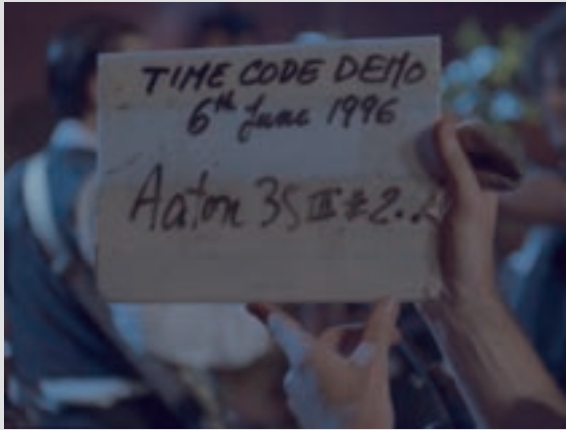

Aaton: Aaton Code demo in Los Angeles in 1996 - Fonds Aaton/La Cinémathèque française

### Aaton Friends and Associates

In addition to the various tests that make it possible to partly map the partnerships formed by the firm and more generally the circulation of Aaton devices around the world (with about twenty tests, already mentioned, for Panavision in 1999 or for Moviecam in Austria, or tests of stillness in 1985 for cameras sold to the Radiodiffusion Télévision Algérienne), some elements of the film collection are the occasion to appreciate the influence of and the interest in Aaton through meetings with creators (in cinema, but also in television and video) to whom the engineer is listening. Since the Maysles brothers' visit to Grenoble, "cameramen and directors come to visit us frequently, and force us all to question the quality of our machines,<sup>32</sup>" Beauviala liked to underline. The permanent exchange with the users of the devices is indeed one of the characteristics of the company. Two reels on Ektachrome film (color reversal) kept at the Cinémathèque bear witness to the meeting of Jean-Pierre Beauviala with Jean Rouch in Grenoble, filmed

<sup>32</sup> BERGALA A., HENRY J.-J. and TOUBIANA S., art. cit., p. 12.

<sup>33</sup> Gérard de Battista also remembers having taken part in February 1973 "in an event shooting on the occasion of the Grenoble Short Film Festival: a film about the festival, shot with a brand new camera, in black and white reversal film [...]. The editing room had a glass wall so that the audience could watch the director and chief editor Annie Tresgot work." DE BATTISTA G., "Les gentils ronrons de l'Aaton," Lettre AFC, n° 297, May 2019, p. 25.

by Gérard de Battista in Super 16 with the prototype of the Aaton 7 (whose battery is not yet incorporated in the camera)<sup>33</sup>. An opening card reads: "This is not a film but a platform for discussion"—a discussion that escapes us, however, the sound, recorded by Michel Faure, has not been found for the moment.

For his part, Jean-Luc Godard settled in Grenoble for a while in order to exchange with Jean-Pierre Beauviala, to whom he ordered a camera in 1976 to capture spontaneous moments. It must combine the image quality of a 35 mm camera with the advantages of a Super 8 camera (reduced size and automation). It will be the 8-35, or at least its prototype, whose film collection includes a few reels of camera tests, shot in 1979 in Paris, Grenoble and Switzerland by William Lubtchansky, assisted by Caroline Champetier, and probably Jean-Bernard Menoud. The collection also contains a reel of dailies, with similarly distorted colors, made during the shooting of *Passion* (1982), the opening shot of which was shot by Godard with the 8-35. Also preserved, an incomplete copy of *Prénom Carmen* (1983) reminds us that certain night scenes of the movie, shot with an Arriflex, were done in



Aaton : Jean-Pierre Beauviala meets Jean Rouch in Grenoble (1973) - Fonds Aaton/La Cinémathèque française



Paris with the 8-35, whose design did not succeed for various reasons<sup>34</sup>, its prototype being preserved today at the Conservatoire des techniques de la Cinémathèque française.

In their own way, the filmmakers also allow Beauviala to test his equipment in real, even extreme, conditions. Thus, the director-anthropologist Éliane de Latour was led to test Aaton's prototypes in the harsh climates of Africa<sup>35</sup>, notably during the shooting in Niger of *Temps du pouvoir* (1985). On site, the devices made a strong impression and inspired local artists who reproduced their outward appearance in filmed can sculptures—as can be seen thanks to the collection—and eventually brought back to France by de Latour. Other images bear witness to trips at Lasalle in the Cévennes, in the company of anthropologist and filmmaker Marc-Henri Piault. It was in this village that Éliane de Latour shot her film *Le Reflet de la vie* (1989)<sup>36</sup>, Aaton having participated as co-producer in several of her projects.

But before exploring remote territories, Aaton cameras recorded, during their technical tests, which can be accessed in the collection, the life of the company in the center of Grenoble. While the original purpose of these reels, which are primarily meant to test devices, may not be obvious at first glance, the contemporary viewer appreciates to discover the employees who were the beating heart of the company. It allows us to see the stock of spare parts or understand the configuration of the offices open to the city center thanks to large bay windows emblematic of the “transparency” of the company advocated by Beauviala. As Alain Bergala points out, Aaton was an unusual factory. It was more like a design, research, invention, testing and assembly bureau<sup>37</sup>. Beauviala for his part said: “We



Fonds Aaton/Conservatoire des techniques de la Cinémathèque française



Fonds Aaton/La Cinémathèque française

**34**  
Cf. BEAUVIALA J.-P. and GODARD J.-L., “Genèse d’une caméra 1 & 2,” *Cahiers du cinéma*, n° 348-349, June-July 1983 p. 94-111 and n° 350, August 1983, p. 45-59. For a detailed study, we refer the reader to SORREL V., “L’instant fatal où la lame se brise, (à propos de la caméra 8-35,” A.DE BAECQUE and G.MOUËLLIC (dir.), *Godard/Machines*, Crisée, Yellow Now, 2020, p. 31-55.

**35**  
Cf. *Citizen Beauviala*, *op. cit.*

**36**  
This film consists in part of still images taken from photographs by Jean-Pierre and Julien Beauviala.

**37**  
“Camera # 5: Penser une caméra,” meeting led by Alain Bergala, “Cinéma du réel” Workshop, 2011.

do not machine or transform anything, no *stricto-sensu* manufacturing, neither in electronics nor mechanics[...] Everything here is made outside<sup>38</sup>,” as can be seen in the test images, of which we remember mostly the faces. Among the employees, we can thus recognize as soon as 1975, in a test of the time marking, Thora van Male, “Aaton’s general secretary in the beginning.” Beauviala says: “She was in charge of communication and advertising, of finance ... she accompanied me all over the world, negotiated contracts with agents, she single-handedly created the Aaton New York office.”<sup>39</sup> In 1982, no doubt in the context of the Arri lawsuit<sup>40</sup>,



Sculptures made out of tin cans - Photo : Alain Bergala

Jean-Pierre Beauviala and Thora van Male visited the Redlake company in California, as can be seen in a film from the collection showing them studying the Locam high-speed camera and its pivoting viewfinder. Back in Grenoble, the surroundings of the Aaton offices are the place to be: the animation in the rue de la Paix, the brasserie Le Glacier, the place Notre Dame, etc. In December 1981, Vincent Blanchet thus shoots in Grenoble a reel entitled “*Sortie des usines Aaton*,” with

<sup>38</sup> BERGALA A., HENRY J.-J. and NINEY F., “Fausse sortie des usines Aaton et entrée des artistes dans le montage virtuel, entretien avec Jean-Pierre Beauviala,” *Cahiers du cinéma*, n° 410, July-August 1988, p. 54.

<sup>39</sup> DE MARI A., “Entretien avec Jean-Pierre Beauviala, sur le fonctionnement de l’entreprise Aaton,” *Création Collective au Cinéma*, n° 02, 2019, p. 208.



Aaton employees à Grenoble - Fonds Aaton/La Cinémathèque française



Redlake’s high-speed camera swivel viewfinder - Fonds Aaton/La Cinémathèque française

<sup>40</sup> Arri accuses Aaton of copying his swivel viewfinder. The lawsuit will last several years and will end with Aaton S.A. filing for bankruptcy.

<sup>41</sup> The same year, the latter directed the film *L’Absence* in which the same actress plays.

Jean-Pierre Beauviala, Bernard Dechaumel and the architect Jean-Jo Verdet visiting the construction site of Jean Pierre's apartment, located under the roofs. Among the items in the collection are also traces of another film by Blanchet—with whom Beauviala and others founded the Ateliers Varan in 1980, under Rouch's impetus—, the feature-length fiction film for television *Oublie les dix ans qui viennent* (1983).

The collection also shows that a link is being established between Jean-Pierre Beauviala and the local arts scene, for example with the Grenoble dancer and choreographer Jean-Claude Gallotta. In 1983, Beauviala was probably responsible for the recording of a show by the Émile Dubois company at the Chartreuse de Villeneuve-lès-Avignon during the Avignon Festival, a show entitled *Hommage à Yves P*, also a poet from Grenoble. Six years later, Beauviala signed a sort of making of in 16 mm of *Rei Dom ou la légende des Kreuls* (1989), the first fiction movie that Gallotta made with Claude Mouriéras using 35 mm Aaton cameras under the direction of chief cinematographer Bernard Cavalié. Around the same period, Alain Bergala's film *Incognito* was shot in Mens, this time with an Aaton camera in Super 16 format, and in front of it, Jean-Pierre Beauviala, as well as Arielle Dombasle, whom the latter filmed in 1992, with a book in hand—*Essai sur la fatigue* by Peter Handke<sup>42</sup>—in a preserved film with enigmatic directing.

But one element of this collection, with its already very eclectic content, shows even more directly Jean-Pierre Beauviala himself as a director. Indeed, if in the beginning he could not carry out his initial idea of a film challenging modern city planning in Grenoble for lack of suitable tools, it was with a Éclair 16 camera and a Nagra that he and Suzanne

Rosenberg filmed a documentary on Larzac where they went in 1972 following the announcement by the Minister of Defense of the enlargement of the military camp there. They brought back a 27-minute report funded by Aaton, the *Comité de sauvegarde du Larzac* and *l'Université Paris 7*, and dedicated to the "Operation Open Farms" set up by farmers to show that the image propagated by the government through the media did not correspond to reality.



**Shooting of *Rei Dom ou la légende des Kreuls* (Jean-Pierre Gallotta, 1989) - Fonds Aaton/La Cinémathèque française**



**Opération fermes ouvertes, Larzac Pâques 72 (Jean-Pierre Beauviala and Suzanne Rosenberg, 1972)**

<sup>42</sup> A reversal Ektachrome for the image and a sound negative from a re-recording of the magnetic soundtrack. The image is in poor condition as the element has been shown extensively in ciné-clubs throughout France to raise public awareness of the subject.

Indeed, Larzac was not a desert with a few old people living in ruined houses. To the contrary, the region was dynamic and young families had regrouped there, installing modern tools such as rotolactors to milk sheep. The 16 mm double system element<sup>42</sup> and the few trims kept by the Cinémathèque française thus constitute a rare testimony to complete the portrait of an engineer open to others. Despite his disappearance, the effects of the influence of Jean-Pierre Beauviala and the Aaton Company in the field of cinematographic art, both on a human level and a technological level, are still widely noticeable through the multiple aspects of a unique collection in its own kind, whose great richness is likely to fuel equally varied research.

#### **MARIANNE BAUER AND SIMON DANIELLOU**

**Marianne Bauer, film archivist at the Cinémathèque française, is the coordinator of the exploration of the films contained in the Aaton Collection submitted by Jean-Pierre Beauviala. She has worked on the inventory, on cataloging and on promoting this collection.**

*Marianne Bauer, documentaliste film à la Cinémathèque française, est coordinatrice de l'exploration des films contenus dans le fonds Aaton déposé par Jean-Pierre Beauviala. Elle a travaillé à l'inventaire, au catalogue et à la perspective de valorisation de ce fonds.*

**Simon Daniellou is a lecturer in film studies at the University of Rennes 2 and a member of the Beauviatech research program for which he explores the Aaton film collection. He is particularly interested in the impact of technology in general and the inventions of the French firm in particular on the choices in découpage in cinema.**

*Simon Daniellou est maître de conférences en Études cinématographiques à l'Université Rennes 2 et membre du programme de recherche Beauviatech pour lequel il explore le fonds film Aaton. Il s'intéresse notamment à l'impact de la technique en général et des inventions de la firme française en particulier sur les choix de découpage au cinéma.*





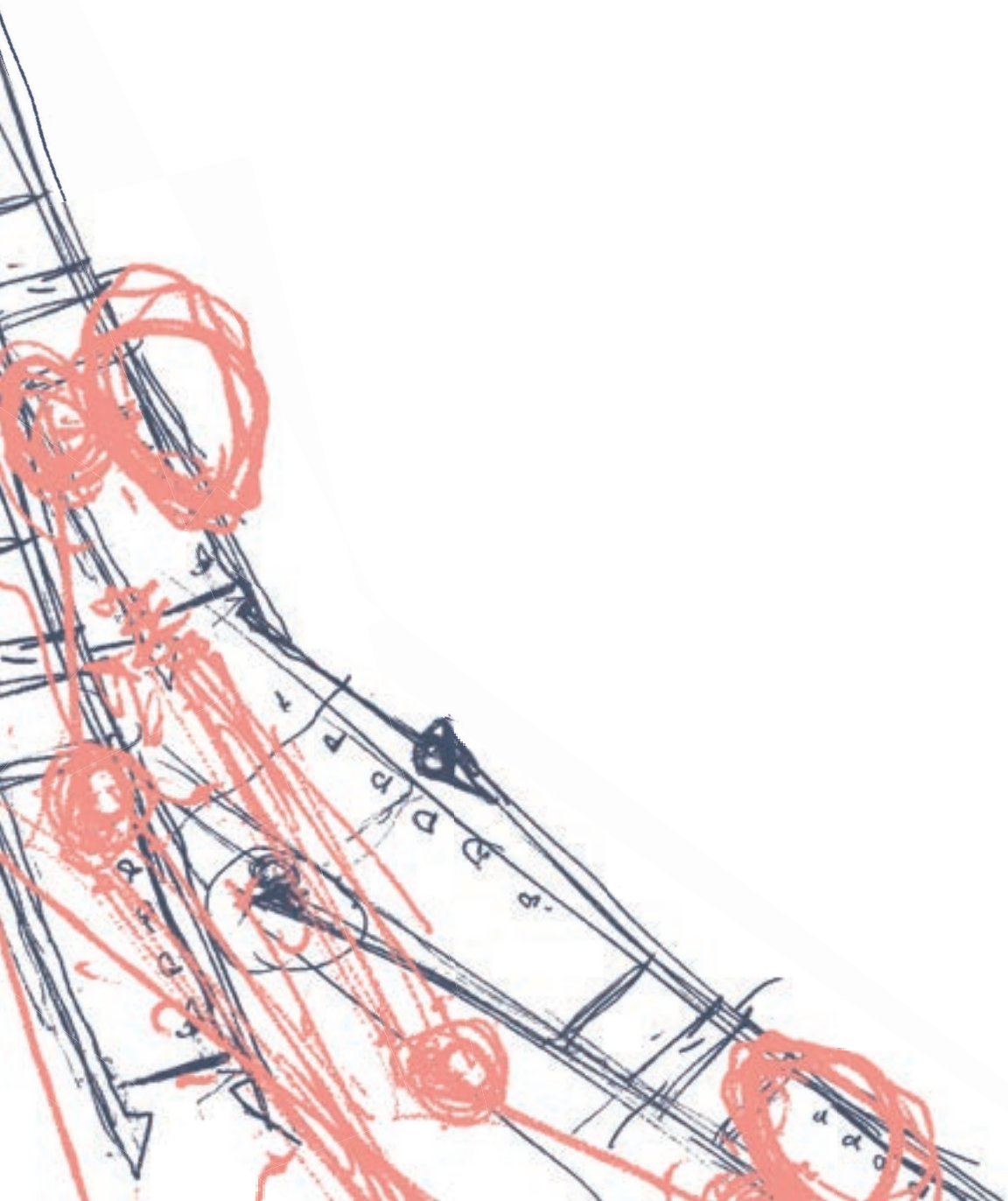



**2.**

**Imagining, Designing,  
Reinventing, Patenting,  
Experimenting**





## Jean-Pierre Beauviala before Aaton: From High School to Éclair

Alexia de Mari

### Abstract :

Since his high school years, professionalism and precision have been part of Jean-Pierre Beauviala's daily life. In 1962, he set up his own color photographic laboratory to develop negatives and positives and make prints. In 1971, he established the Aaton Company in the old premises and with former members of Éclair. His time at Éclair allowed him to gain experience as an engineer and researcher in the development of cinematographic devices. Neophyte and self-taught in the field of motion photography until the mid-sixties, this apprenticeship allowed him to train and acquire a solid foundation for the creation of a new business.

### Résumé :

*Depuis ses années de lycée, professionnalisme et précision font partie du quotidien de Jean-Pierre Beauviala. En 1962, il installe son propre laboratoire photographique couleur afin de développer les négatifs, les positifs et réaliser des tirages. En 1971, il crée la société Aaton dans les anciens locaux et avec d'anciens membres d'Éclair. Le passage chez Éclair lui a permis d'acquérir une expérience en tant qu'ingénieur et chercheur, dans la mise au point d'appareils cinématographiques. Néophyte et autodidacte dans le domaine de la prise de vue animée jusqu'au milieu des années 1960, cet apprentissage lui permet de se former et d'acquérir des bases solides pour la création d'une nouvelle entreprise.*

The name Aaton seems inseparable from that of its creator, Jean-Pierre Beauviala, a company of

which he was the director until 2013. His choices as a business executive and engineer, guided by the ambition to impose Aaton in a highly competitive market, were influenced by a singular career path and a vision of the world that is not widely shared in the business world, which gives a better understanding of the path that led him to set up his company in Grenoble. Son of an engineer who was at the origin of several patents, his early inventiveness made Jean-Pierre Beauviala a very young creator of technical objects. A keen photographer, he is interested in how cameras operate, film processing and paper printing. In his teenage years already, he carries out many projects between crafting and research in order to create his own equipment. During his high school years, he familiarizes himself with engineer practices by presenting his work and not hesitating to call on professionals to help him carry out his projects. With the help of draftsmen from his father's company, he designed an auto focusing enlarger while he was still a high school student<sup>1</sup>.

This complicated project will not come to fruition, but this experience will be important for his training. He quickly plans to create his own laboratory with the acquisition of a Durst enlarger, thus continuing his work in the field of photography, an episode recounted as follows by Beauviala himself: "I took all my savings for three months, where I must have only eaten blédine, instead of going to a restaurant, I don't know what. And with all the money my parents sent me, I bought this famous enlarger."<sup>2</sup>

In 1955, Jean-Pierre Beauviala showed audacity by proposing to Semflex<sup>3</sup> to modify their

<sup>1</sup>

The sources on which this text is based are partly taken from the two archival boxes named *JPB avant Aaton*, boxes included in the Aaton Collection preserved at the Cinémathèque française. The contents of these two boxes were commented on by Jean-Pierre Beauviala during several interviews conducted by the author of this text accompanied by Caroline Champetier, in January 2019. The archival drawings referred to in this text are found in these boxes. The enlarger's drawing is undated but Beauviala estimated that he had done this work between 1955 and 1956.

<sup>2</sup>

Interview with Jean-Pierre Beauviala, "JP Beauviala avant Aaton (2/3)," conducted by Alexia de Mari with the presence of Caroline Champetier, Paris, 23 January 2019.

<sup>3</sup>

Correspondence present in the archives *JPB avant Aaton*, Aaton Collection, Cinémathèque française.

cameras in order to optimize the surface of the photographic film. “It allowed me to do normal 24x36 but also 24x60, that is to say one for two [...]. Like an idiot, at the time I didn’t write to the Germans, to Arriflex. To go outside the hexagon was not something you would do at the time.<sup>4</sup>” Semflex engineers responded by acknowledging the accuracy of his ideas, apparently regretting that they lacked the funds to invest in such a project. This work already echoed the operation of the Super 16 which would be developed by Aaton in 1971. Long before the creation of his first cameras, Jean-Pierre Beauviala’s goal was to optimize the use of film and its development process by creating simple systems that could be industrialized and that allowed to lower costs without losing quality. He therefore solicited companies (Semflex, Boyer Objectif etc.) very early on to submit his ideas or try to understand how other users or manufacturers solved the problems he encountered. He thus assumed a researcher’s stance very early on, documented himself, and made contact with people who could help him skillfully and simply resolve the problems he encountered as a practitioner.

In 1962, he set up his own photographic laboratory in order to develop very complex and expensive color prints. Beauviala’s objective was to use the minimum amount of chemicals to avoid unnecessary waste. To achieve this, he designed large, very thin glass vats placed vertically in which the photographic paper was inserted. He determined the ideal size of the tanks and the adequate volume of products to be used according to the cost of each product<sup>5</sup>. Research work allowed him to study the effect of filters on colors. Long before joining Éclair and founding Aaton, the young Beauviala was already very mindful of

process efficiency and economic constraints, while considering very large-scale production.

After high school, Jean-Pierre Beauviala began an electronic engineering academic course in Grenoble. He dedicated his graduation thesis at the ENS to high-fidelity sound reproduction. In parallel to writing it, he had to create, for this same academic course, a functional prototype of an electronic device. He chose to build an amplifier “taking care of the aesthetics, the box and the control knobs. [...] Which bodes well for what happened for me afterwards: when I was developing useful instruments, I attached great importance to design as such. [...] This is obvious in the Cantar, for example. I didn’t do the design afterwards.<sup>6</sup>” After graduation, he went on to complete his PhD and, together with Hugues Vermeilles and another PhD student<sup>7</sup>, he was part of a working group for speech analysis and synthesis. In April 1969, while planning the end of his thesis for the month of July (it was never completed), he planned to develop a second research subject on photographic chemistry and was hired as an assistant professor. During these years, he became interested in cinema and it was as a cinephile that he became head of the Grenoble ciné-club. In conjunction with his engineering research work, he started, in the mid-sixties, a project to make a documentary film on city planning in Grenoble. Driven by his political ideas which partly guided his career, he hoped to denounce the city planning project of the ville nouvelle<sup>8</sup>. He wanted to record the sounds independently of the image in order to share the perception of the singularity of the space at the time of filming. He invested in the purchase of an Arriflex and a Nagra, the two devices were connected by a synchronization wire. But he

**4** Interview with Jean-Pierre Beauviala, “JP Beauviala avant Aaton (2/3),” conducted by Alexia de Mari with the presence of Caroline Champetier, Paris, 28 January 2019.

**5** Notes and drawings collected in *JPB avant Aaton*, Aaton Collection, Cinémathèque française.

**6** Interview with Jean-Pierre Beauviala, “JP Beauviala avant Aaton (1/3),” conducted by Alexia de Mari with the presence of Caroline Champetier, Paris, 28 January 2019.

**7** *Groupe pour l’analyse et la synthèse de la parole*, 15 April 1969, *JPB avant Aaton*, Aaton Collection, Cinémathèque française.

**8** Jean-Pierre Beauviala talks about this project on numerous occasions, notably in Alain Bergala, Jean-Jacques Henry and Serge Toubiana. “Entretien avec Jean-Pierre Beauviala,” *Cahiers du cinéma*, n° 285 (n.d.): February 1978, and Alain Bergala, Jean-Jacques Henry, and François Niney, “Stratégie du temps - Beauviala story 1/3,” *Cahiers du cinéma*, n° 409 (June 1988).



**Very precise, quartz is used in radio transceivers with a stability in the order of one millionth of a Hertz. This precision guarantees perfect remote synchronization between film and sound.**

realized that in practice the wire did not allow him to capture images and sounds independently while ensuring synchronicity: camera and recorder depended on the wired connection. He then constantly endeavored to make this remote synchronization possible. To achieve the necessary precision, he controlled the Arriflex's motor with a quartz clock, a bleeding edge device in electronic technology at the time. Very precise, quartz is used in radio transceivers with a stability in the order of one millionth of a Hertz. This precision guarantees perfect remote synchronization between film and sound. Other synchronization systems were invented at that time, notably based on the tuning fork watches developed by Bulova, which were less precise than quartz. All these experimentations took place independently of each other and were often the work of ingenious technicians and filmmakers like the Maysles brothers. Intrigued by the advertisement highlighting the silence of the Éclair 16, Jean-Pierre Beauviala went to Éclair during a visit to Paris in 1968, and took the opportunity to present them with his project of remote synchronization. Éclair engineers confirmed their interest by lending him a camera in order to conduct motor tests, before suggesting he filed a patent and sold them the motor license. This patent<sup>9</sup> will be one of the three patents<sup>10</sup> filed by Jean-Pierre Beauviala before the creation of Aaton.

In 1969, he joined the Éclair-Mathot team as a consulting engineer. Part of the SECLER branch (Société Éclair Etudes et Recherches) of the company, he quickly became its director after having asked for an unpaid leave from the University<sup>11</sup>. He

hires electronics engineer Hugues Vermeilles<sup>12</sup> in his team, alongside Jacques Lecoeur and François Weulersse. Beauviala was careful to condition his engagement with Éclair on the creation of his design office in Grenoble, a condition accepted by director Jacques Mathot. In his own name, he rents<sup>13</sup> a space in the old town and installs his laboratory there. This location at the heart of the city echoes the ideas that had motivated his unrealized desire for a documentary. At Éclair's request, the team works mainly on a *single-system* project, with sound and image on the same medium. If Beauviala had some reservations about a system whose consequence will be to frame "by sound"<sup>14</sup> according to him, he must, however, put his personal work aside for a while, notably regarding chronometric marking. He finds the solution to the problem posed by the *single-system* by focusing his attention on the sound instead of trying to constrain the scrolling of the film:

"Finally seeing that the pre-existing solutions were leading to heavy, bulky, stuff unsuited for ►

<sup>9</sup> *Registre à décalage*, Filed: 27/05/69, Issued: 8/02/71, Depositor: J-P Beauviala, Warrant: R. Baudin. Source INPI

<sup>10</sup> The other two patents are "*Dispositif d'enregistrement et de lecture évoluant dans le temps*" (Recording and reading device evolving over time), Filed: 8/06/69; Issued: 15/02/1971; Depositor: J-P Beauviala and "*Perfectionnement aux appareils de prise de vue et de projection de films cinématographiques*" (Improvements in cinematographic film shooting and projection equipment), Filed: 3/07/1969; Issued: 29/03/197; Depositor: J-P. Beauviala.

<sup>11</sup> Archival Document *JPB Avant Aaton*, Aaton Collection, Cinémathèque française.

<sup>12</sup> Hugues Vermeilles will stay with Aaton for several years but tensions will arise between the two men. Jean-Pierre Beauviala praises the work of the electronics engineer who "made extraordinary plans" but not suited to corporate work which has to work with economic and commercial constraints. Aaton's goal is to propose relevant innovations in a short time, as long research is too expensive. Following the departure of Vermeilles, Jean-Pierre Charras, also a former student of the ENS Grenoble, will join the Aaton team.

<sup>13</sup> DE MARI A., « Entretien avec Jean-Pierre Beauviala sur le fonctionnement de l'entreprise Aaton », BONHOMME B. et LABROUILLE I. (dir.), *Création Collective au Cinéma*, n°2, « L'équipe de film, innovations et inventions », 2019.

<sup>14</sup> BERGALA A., HENRY J.-J. and TOUBIANA S., "Entretien avec Jean-Pierre Beauviala," *Cahiers du cinéma*, vol. 285, p. 10, February 1978.

the 16 mm magazine, I turned the problem around by saying, I'm not going to try to regulate the movement of the film, I'm going to work on the sound itself. [...] The jerks in the film, you measure them and you jerk the sound at the same rate, so that the jerky sound applied to a jerky tape is aligned correctly.<sup>15</sup>

The sale of his third patent, submitted in July 1969, to Éclair<sup>16</sup>, allowed Beauviala to invest in the creation of Aaton. The situation deteriorated fairly rapidly between Éclair and SECLER employees after the takeover of the parent company by Swiss Holding company Fodel in 1968. Managing director Harry Salzman encouraged the creation of a new miniaturized camera, the Mini 16. At the same time, he decided to take control of SECLER by appointing a new director and relocating the design office to England. In a letter to management, Jacques Lecoeur and François Weulersse report that tensions have arisen from the too short timeframe given for the design of the Mini 16, foreseeing the technical problems to come. They also mention the opacity of management towards them, surprised that Jean-Pierre Beauviala is not informed of the management's decisions, and regretting their lack of means. This letter remained without effect, and François Weulersse, Hugues Vermeilles, Jacques Lecoeur and Jean-Pierre Beauviala informed management that they planned to leave Éclair. But the company made the first move by firing Beauviala during the 1970 Photokina trade show. The electronic devices were returned to Éclair, but Beauviala kept his premises in Grenoble and in 1971 he created his own company based on his know-how and his network, and accompanied by several of his collaborators who had become loyal followers.

His time at Éclair allowed him to gain experience as an engineer and a researcher, particularly in the development of cinematographic devices. Neophyte and self-taught in the field of animated photography until the mid-sixties, he gained solid foundations for the creation of his new company, surrounded by excellent professionals who were very aware of the market's challenges. Aaton's adventure could begin.

<sup>15</sup>  
*Ibid.*

<sup>16</sup>  
*Perfectionnement aux appareils de prise de vue et de projection de films cinématographiques*, deposited on 2/07/1969, issued on 29/03/1971, depositor: JP Beauviala, agent: R. Baudin. Source INPI.

## Jean-Pierre Beauviala: Thoughts on Inventions

Bérénice Bonhomme  
Frédéric Tabet

### Abstract

Jean-Pierre Beauviala came on June 13 and 14, 2017 at ESAV (now ENSAV), for a conference and a workshop with students around the cameras. On this occasion, he gave this long interview on the question of invention and its way of understanding it, associating many drawings to his explanations.

### Résumé

*Jean-Pierre Beauviala est venu le 13 et 14 juin 2017 à l'ESAV (actuellement ENSAV), pour une conférence et un workshop avec les étudiants autour des caméras. À cette occasion, il a donné ce long entretien sur la question de l'invention et sa façon de l'appréhender, en associant à ses explications de nombreux dessins.*

### Of the importance of shower

"I often have ideas in the shower: ideas mature through the night. In the morning, you have to stay in a nebulous state when you get up and the shower accompanies your coming to the real world, it is a meeting between dream and reality. I remember an important idea I had like that, in the shower. For the A-Minima, I kept thinking about how to avoid problems with the presser. We wanted to get rid of the lateral guiding of the film while keeping the same stillness that was a bit of our trademark. The German manufacturer ARRI made super 16 cameras with image with stillness defects. Our cameras were very still, that's

what made Aaton special and that's what allowed enlargements in 35 mm.

But, with a side presser, there are always impurities that get under the skate and jam it. I was thinking, we're not gonna get stuck on that presser again. We were thinking about pendulums, but it wasn't very operational.



Jean-Pierre Beauviala

One morning, all of a sudden, I said to myself that we shouldn't be sliding the film, we should be rolling it. We're going to make a pin that's going to be attracted to a magnet and instead of sliding, the film's going to roll. And I thought about the pin.

When I arrived at the office in the morning, I made a sketch ... or not even, I certainly explained it to Aaton's chief drafter. I probably didn't do the drawing myself. ►

Once I had the idea, we made a small prototype. And abandoned the pendulum idea we were working on. This episode was when we were building the *essential bricks* of the camera's operation."

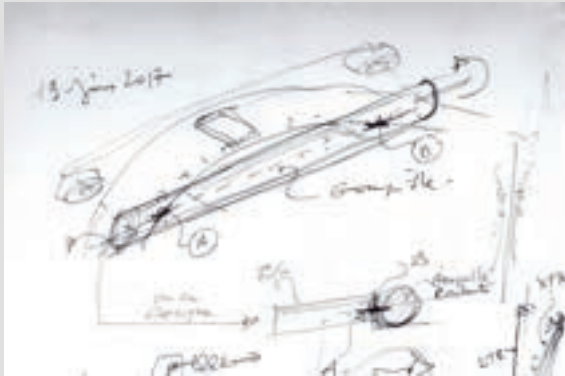

Jean-Pierre Beauviala

### The Essential Bricks, or, How to Draw a Camera?

I start with the ergonomic model of the camera. Where's the hand? Where's the eye? I think about the position, about the size, I draw a "master plan." Then come the bricks: Where do you put the film? How does the film get past the window ... it's a more technical job.

For the Aaton 16 LTR camera, I was guided by Éclair's legacy. I didn't so much question the internal movement, the claw movement. I trusted Jacques Lecœur. I had taken the Éclair 16 model, added a more powerful engine and a differently designed viewfinder. This camera was born the day I thought of the flat and shoulder motor. When I design a camera, it's to be able to make cinema in a different way, I think above all about ergonomics. Then, I pay

attention to the *bricks*: for the A-Minima, we had the drive, the claw movement (invented by Lecœur and Leroux), the magazine that opened to let the film pass through (and that allowed for loading "in daylight"). It was full of inventions.

### The A-Minima, an Invention that was a Failure and a Success

The A-Minima is a good example of a successful invention ... that didn't manage to find its audience. At the beginning, it was very small, it was designed after my work on the 9.5 mm which had not given anything. It was a camera for enlightened amateurs. We showed it to users and professionals who told us: "Oh, you absolutely must have video relay ... you have to have high-speed capacity..." The body of the camera grew with an "accessorization" I hadn't initially planned. I was in love, on a trip to USA for a project, and then I let it go: the camera took on "weight," and became a camera for professionals.

At that point, the problem of loading the film arose: it was a bit long with the A-Minima, which was unacceptable for professionals. In addition, Kodak had pushed us to make film reels that allowed daylight loading with flanges. It's technically brilliant, but completely idiotic: all you had to do was rethink the loading bag. We would have had to make a slightly more expensive camera, with an instant loading magazine. There we were left with a complex loading process, which may be fun for an amateur, but unacceptable for professionals under their working conditions.

I remember Renato Berta coming to my house in Mens in 1998. I show him the A-Minima, which was

very advanced. I show him the loading process. He says to me, "You're completely crazy." It took him a very long time to get used to loading it and I kept telling him, "But no, it's simple!" ... I was quite ridiculous. When Renato Berta came by, it was too late, we were too far along.

The camera came out two years later. I remember that H el ene Louvart, the chief operator on Dominique Cabrera's *Le Lait de la tendresse humaine* (2001), hesitated to take an A-Minima. She was tempted by the camera, but the assistant told her it was too complex to load. I was in Paris, I went to meet Dominique Cabrera. I can still see myself at her house in Montreuil, in her room, sweating blood and water to load the camera. I made a fool of myself ... and she didn't take the camera.

The A-Minima was a beautiful misfire even though it had a better image than the XLR, it was full of inventions. The little curve of the film, obtained with the pin, was great, the film was not breathing at all. It was a perfect camera, the far-eye viewfinder was fabulous.

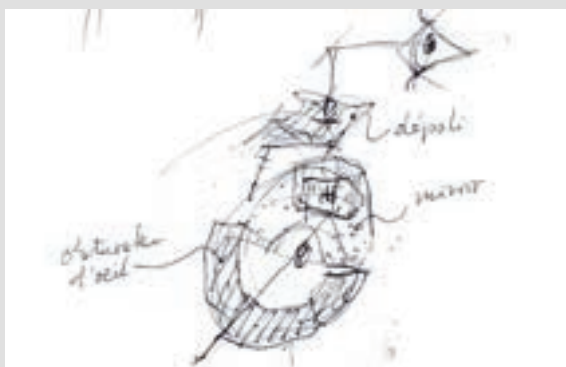

Jean-Pierre Beauviala

## When it's Too Late, How Should You React?

I think the A-Minima story must have played unconsciously on my reaction at the time of the Cantar. I told myself that I had been stupid, that maybe it was laziness on my part, or inertia: when there's a crew of several technicians, each one is aware of the work they've done and it's hard to bin your hard work and go back. For the Cantar, for the first time, I completely imposed things... Let's go back to the origin of the story.

At the time, we were very involved in post-production with the *Keylink*, the time marking. The cameras weren't really what made us money, because there were too many research costs. On the other hand, *Keylinks* were sold all over the world, this system would make it possible to synchronize image and sound as quickly as possible. Since we had a reputation for being the kings of synchronization, we proposed a new system: "Whatever the origin of your sounds, we transfer everything to hard disk and at Aaton, we guarantee that this transfer will keep the original quality." As soon as the information was on hard disk, in the lab, they were sold an "Indo" to digitize the sound. Once it was done, at the telecinema, we called up the sound to synchronize it. So we had a good reputation with the sound technicians. I said to myself: "We're transforming the sounds of all the recorders. Why don't we make our own recorder?" We had everything in hand, but as long as Stefan Kudelski was in business, I promised myself I wouldn't compete against him. When he left the company, Nagra was a horror show, and I was freed from my promise.

For a recorder, we had all the bricks; we released the Cantar very quickly. The main thing to think about ►

was ergonomics: I wanted the sound engineer to have his fingers on top, nothing on the sides (otherwise it wouldn't fit in the sound carts), I wanted all inputs and outputs downwards, a suspended hard disk... Then there was the question of the number of inputs. I said to myself: "We're going to call on our friends, the big names in Parisian sound recording." We met several times in Paris, four inputs seemed to be enough for them, because multi-track, "it was not worth it." It was a question of corporatist prerogatives, with the underlying idea that it's up to the sound engineer to mix.

So the first Cantar was released at the S.A.T.I.S. in 2002. Bernard Rivoire, the manufacturing director, had already ordered the moulds. I cheerily arrive at the expo with my Cantar and its big buttons. All day long, it was the same thing: everyone was happy, admiring the ergonomics. Then, they would begin to wonder: "There are only four entries? What the hell is?" I realized that I had been advised by a generation of conservatives. Before the end of the expo, I went back to Grenoble, very quickly, to redesign a six-track machine with lots of inputs... A complete revolution. All the foundry tools were good for the trash bin. It was the end of October 2002. Martine Bianco (our financial director) had already promised deliveries for early 2003. Internally, the discussion was heated: "You're screwing up Aaton!" I answered "It's better to destroy the Cantar than to not sell them! I won't sign-off on a machine that will be obsolete before it's even born!"

In the end, my brother put up the money for us to hang on for six months and that saved us. Meanwhile, we rethought everything and in July 2003 the first Cantar was sent to Tu Duu Chih, Wong Kar Wai's sound director on *2046*. It was a gamble: this version

hadn't been tested ... if it had broken down...

Mass production began in October 2003, a year after my "fit of rage," which, nevertheless, had been pretty helpful.

## Inventing For Whom? Inventing For What?

The two previous examples show the difficulty an invention can have in meeting its users. For the cameras, we didn't have a "test panel:" at the beginning, I made the camera for myself, it was my object. But at the beginning of Aaton, we had to build a big camera, a real camera, to look serious. The A-Minima was a return to the beginnings, a project for me: a revolutionary camera that you could put under your bed. The A-Minima was not for "professionals of the profession," it was made for those who are like me, lovers, with an integrated light-meter for example. The Penelope was designed to be used by an image crew, unlike the A-Minima, which is intended for a solo operator. Each camera entails a production system, a crew. And then, for professionals, there is the importance of the gesture. When you're an amateur, you can sink your teeth into whatever your object offers. But a professional, he uses rented equipment, he doesn't have time to learn many new gestures. It's like a rental car, the elements are all pretty much in the same place. It must work smoothly right away and the user has to be able to find his usual automatisms. For the poor Penelope Delta, I had not hesitated to reuse the Alexa's buttons in order to preserve the automatisms.

The camera Jean-Luc Godard asked me for is a good example of the problems of a commission. There's only one copy of his camera. The 8-35 was in 35 mm and I didn't know much about it. I was specialized in



16 mm, I left it to Jacques Lecoœur and I didn't take care of it too much. The camera was ill-conceived, and wasn't loved, because it was thought outside of my passion for drawing. It took us years of work, before we managed to make a silent 35 camera: the Penelope 35. It's the best camera I've ever made, even if I don't like it as much, because it's 35 mm.

One of my most beautiful inventions was the "single system" in the years 69-70 when I was at Éclair. This invention, however, failed to find an audience: American TVs wanted a camera that recorded sound and image. Everybody had broken their teeth on this, because the scrolling of the film is not constant. There was a huge market to take, so I took the problem the other way around: instead of trying to stabilize the speed of the film to match the speed of the sound recording, I sampled the sound to match the irregular rhythm of the film.

In a sealed box, I had put a converter that digitized the sound, sampled it and matched it to the bad frequency of the film: it could then be inscribed on the film itself. I didn't regulate the movement of the film, I adapted the sound to its madness. It's for me the most beautiful of my inventions, the most complicated one at every level. As an academic, I had the knowledge to do time digitalization, but nobody understood what I was doing, nobody understood that I had used a time compressor. No one found Beauviala's trick. Anyway... I started to develop time marking at the same time, which was the other solution for synchronization. So I was competing with myself. And then I got fired from Éclair. And I founded Aaton. All this delayed things, the "single system" did not go forward and in 75 the Sony BVU was adopted by all the televisions: the single system was never adopted. It's a matter of timing.

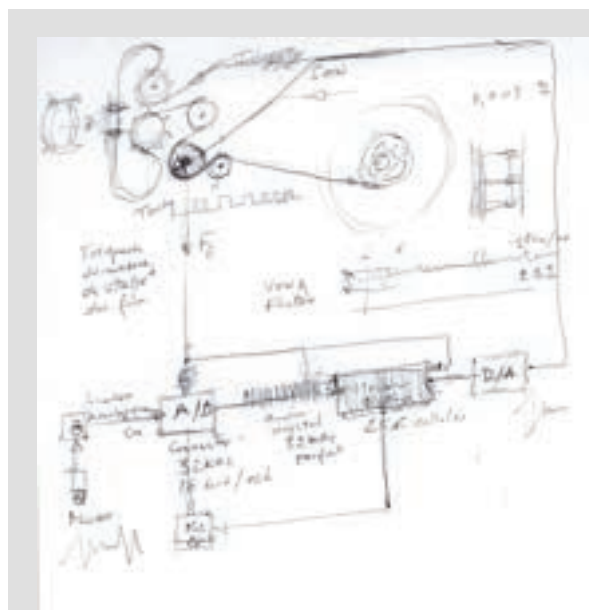

Jean-Pierre Beauviala

Another beautiful invention, which this time came just at the right time: the magnetic drive. I was in China in February 1984. We were going through ARRI's American lawsuit on the viewfinder that changed sides. We lost the lawsuit and the financial damages were disproportionate, impossible to absorb. Martine blew up the company. But in order to restart with another company on the right foot, we needed to have orders, to have money. There was a market opening up in China for 50 cameras. Martine sent me to China and I stayed there for two months. A middleman had introduced me to everyone. Meanwhile, I was selling the LTR whose internal mechanisms were not mine (we had used the Éclair's movement). One day I'm in front of this camera in my hotel in Beijing and I'm wondering about the drive system. I was representing it to myself. From my window, I could see streams of ►

bicycles and very few cars. The LTR, the drive system is a horror. I tell myself it's a disaster: if we sell this in England, we can come and fix it ... but in China?

I finally came up with the idea of the magnetic drive. The good invention that the Germans never copied. I come back from China, big meeting, we're gonna have a 98% chance of getting the order for 50 cameras. Three Chinese are going to come in July. We have three months to do this: I show my drawings. There were a lot of modifications to be done, because of the magnetic drive. At the end of July, the XTR camera worked; at the end of October, all fifty cameras were delivered. We didn't even go through prototypes. And the crazy thing is, not one of these cameras ever came back. They went through everything, but I think they fixed everything themselves.



Jean-Pierre Beauviala

### Working in Teams

Aaton is above all the adventure of a team. The one who left Éclair and tried something, even though this state of mind was gradually lost, and eventually, things became personalized around me. When I was fired by the British who had taken over Éclair, the others could see that things were going downhill. The fact that Jacques Lecœur accompanied me was also very important. He had a great aura at Éclair, then the prototypist, the assembler ... all came to

Grenoble, the small group from the beginnings of Aaton. For me, the team was very important because it forced me to see things to their fruition, not to stay in a world of dreams, which is perhaps a form of laziness... I don't know. I love working in a team, even if sometimes it's a bit cumbersome ... in a team you have to move forward.

So, in the beginning, it was the Éclair team, then there were the Lyon and Grenoble areas breeding grounds, with a lot of nuclear engineers for instance. In the end, we employed up to 50 people at Aaton, a very large proportion of whom were in the design office—more than ten—of which I was in fact the head, because I had delegated financial and administrative matters. There was an Aaton “spirit.” At lunchtime, we went to the pool, we often went skiing, all the offices were open, even mine. I was in shorts, boots and a hat, while maintaining a certain academic rigor, especially for the documentation: all the documentation was stamped, in folders that went from service to service. It was an organization of the knowledge flow that was perhaps not “homogeneous” with the image of a guy in shorts, but it was essential. I've kept this academic spirit going for a long time. So I liked (and still do) to explain things on the blackboard.

There was the Wednesday meeting, which in fact, came from my experience in the student unions. Every week, this meeting brought together the department heads (finance/communication/maintenance/mechanical production management/electronic production management/design office) and a few engineers from the design office, depending on the agenda. I had realized in the student unions that, beyond fourteen participants, it was no longer a meeting, but a cacophony. So we always made sure we didn't go over that fateful number.

At Aaton, there were two important choices that were made right away. The agents (who represented Aaton technologies around the world) were most often film professionals who used the equipment. Besides, Aaton wasn't a factory. We only made prototypes, then we used subcontractors ... which was rare at the time. I didn't want a heavy structure, like at Éclair. I had read that in the Swiss watch industry, they just assembled the parts in their factories ... we followed the same model.

When we recruited, there were often several people from the company conducting the interview. Martine had accompanied a friend for recruitment. She was always answering questions for her friend. I've always been fascinated by fast and smart people. It seemed important to me that the members of the Aaton team loved cinema, that they saw movies ... the question of knowledge of cinema techniques was not important then. Martine, I think she was 25 or 27 years old when she became our financial director, instead of her friend. Bernard Rivoire became manufacturing director at the age of 25. Often during a job interview we would ask: "You're on Mars, and you're tired of walking. The aliens have some knowledge of mechanics; make a sketch of a bike so they can build it for you." Drawing a bike gives you a good idea of observation and synthesizing abilities, because we see them every day. There's the one who hangs the chain anywhere, the maniac who specifies everything, the lamp, the crutch, when he was asked for a sketch... There are clear drawings and others that aren't!

At first, I could only do small drawings, in perspective. For technical drawings, "computer design," I learned by watching others. I also learned how to mill by watching millers: I used to come in during the weekend to see how easy it was to make. Today, I'm an inventor and I

don't do anything with my ten fingers anymore. But I had learned how to use the tools, because it's a form of politeness to understand what your team-mates are doing. With the inventor, there was the craftsman...

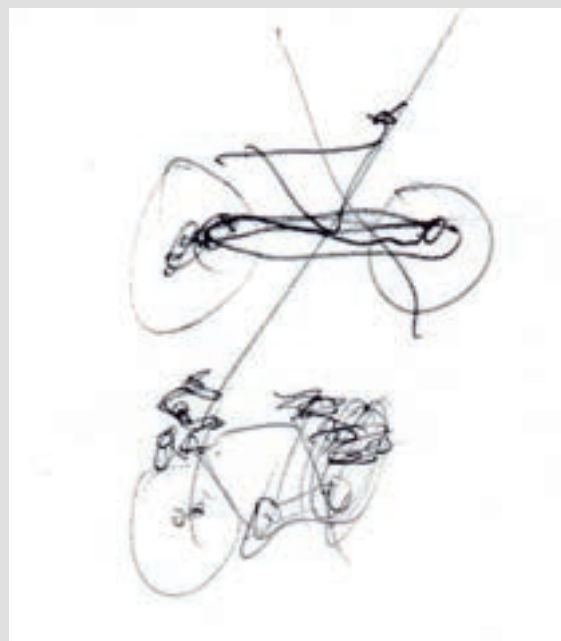

Jean-Pierre Beauviala

## BÉRÉNICE BONHOMME AND FRÉDÉRIC TABET

**Bérénice Bonhomme is an associate professor in film studies at the University of Toulouse II Jean Jaurès (ENSAV). She is a junior member of the Institut Universitaire de France and is part of the LARA-SEPPIA research laboratory. She is currently working on the following themes: Image and Imagination; Cinematographic technique in its relationship to creation; The question of the film crew. She coordinates with Katalin Pór (University of Lorraine, 2L2S) a research project on film crews entitled: "Création Collective au Cinéma."**

*Bérénice Bonhomme est Maîtresse de conférences en cinéma à l'Université de Toulouse II Jean Jaurès (ENSAV). Elle est membre junior de l'Institut Universitaire de France et elle fait partie du laboratoire de recherche LARA-SEPPIA. Actuellement, elle travaille sur les thématiques suivantes : Image et imaginaire ; La technique cinématographique dans son rapport à la création ; La question de l'équipe de film. Elle coordonne avec Katalin Pór (Université de Lorraine, 2L2S) un projet de recherche sur l'équipe de film intitulé : « Création Collective au Cinéma ».*

**Frédéric Tabet is a lecturer in cinematographic studies, in charge of the Master 2 Image course at the ENS d'AudioVisuel. A former student of the ENS Louis Lumière, he has been teaching photography direction for more than 10 years. His research focuses on the archaeology of special effects and its links to magic shows. He is the author of *Le Cinématographe des magiciens* (PUR, 2018) and has co-directed two 2018 & 2020 symposia on the influence of effects on genres and the reception of shows.**

*Frédéric Tabet est maître de conférences en études cinématographiques, responsable du Master 2 parcours Image de l'ENS d'AudioVisuel. Ancien élève de l'ENS Louis-Lumière, il enseigne la direction de la photographie depuis plus de 10 ans. Ses recherches portent sur l'archéologie des effets spéciaux et ses liens avec le spectacle magique. Il est l'auteur de *Le Cinématographe des magiciens* (PUR, 2018) et a codirigé deux colloques en 2018 et 2020 portant sur l'influence des effets sur les genres et la réception des spectacles.*

## A Founding Patent: The Claw Movement of the Aaton 16

| Alexia de Mari

The patents filed by the Aaton Company reveal the effervescence of the research and development undertaken by the company from its beginnings.

They can be categorized into three main groups:

- the key patents: the innovations that were presented were used for the Aaton devices and are essential;
- the protective patents: after, namely, the lawsuit filed by Arri, several tricks are legally protected, whereas up to then patents weren't deposited, as they were considered too expensive;
- the unused patents: but with interesting innovations that may turn out to be used or developed.

“Mechanism to initiate an intermittent movement to a perforated film” was the first patent filed by Aaton, on November 4, 1971. This mechanical patent protects the claw movement developed by the company for its 16 and super 16 mm cameras. First patent filed in the name of Aaton, and key patent, as the claw movement was used for many cameras, from the Aaton 7 to the Xtera. In the 1970s, the main objective of manufacturers aiming at onboard camera technicians is to offer lightweight, robust and silent models. The 16 and Super 16 mm cameras are mainly intended for television and documentary filmmaking. The material must be reliable and resistant in order to avoid technical problems for the camera crew, and is also must be discreet. The precision of the claw movement is essential, because the mechanism has an impact on the image stability, on the silence of the device, and on its reliability. The

Aaton Company rapidly developed a camera capable of standing up to its competitors on a promising market.

### The Importance of Precision

The claw movement, which has an impact on the image stability and on the noise generated by the device, must be stable and quiet. The engineers' objective is to compose with these two constraints, given that “if you don't want noise, you don't have fixity, and if you have fixity, you have noise.” The friction of the parts within the rotation mechanism inevitably generates noise. The objective is therefore to develop a precision mechanism which is very precisely adjusted in order to avoid backlash, which is a source of noise. The beak of the claw must enter and exit the perforations delicately, without brushing against the film in its course. The claw then drives the film to make room for the next photogram. The precision ensures the stability of the film: if the claw does not touch the film when entering and exiting the perforation, there is no additional shaking.

The patent presented here shows that the claw movement is provided by an independent and adjustable horizontal travel and vertical travel, which makes it possible to obtain a very precise movement. The beak of the claw does touch the film during its course. The originality of this innovation lies in the independence of the horizontal and vertical movements. By patenting such a mechanism, the company was able to offer a more silent camera than its competitors. This new claw movement will also be highlighted in advertising brochures, as shown in the extract below: this shows that, from the early years, Aaton was an innovative company capable of finding solutions to problems encountered by technicians. ►

1

Comments made by Beauviala J-P, *Entretien autour des brevets Aaton* (1), by Caroline Champetier, Alexia de Mari and Gilles Mouëllic, November 14, 2018, Paris.

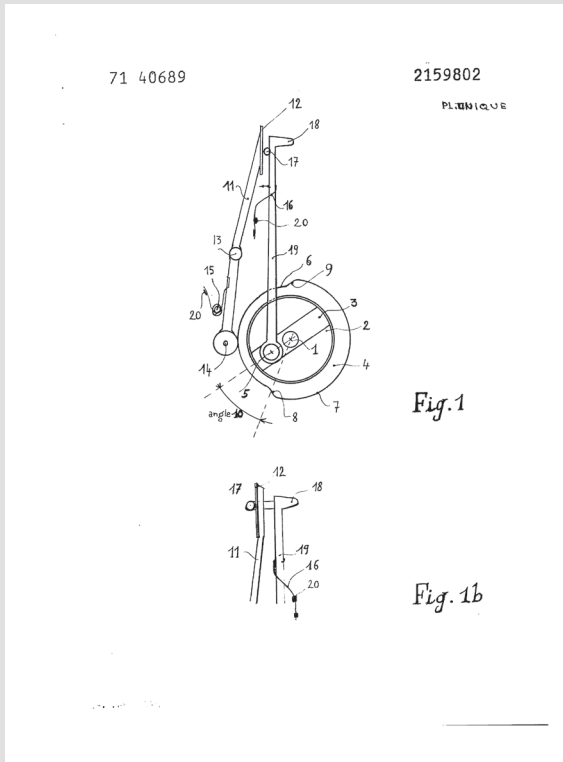

**Drawing of the patent “Mechanism for imparting intermittent movement to perforated film.” Filing 4/11/1971; Issued: May 1973; Depositor: AATON S.A.; Invention of J-P Beauviala; Agent: N.C. - Fonds Aaton/ La Cinémathèque française**

The Aaton LTR was designed to be silent. It is driven by a brushless motor directly linked to the claw movement; power transmission is by high technology gears—no noisy belts. As the film is flat and smooth, as it moves over the aperture plate, it doesn’t need strong rear pressure to hold in place. This means the claw can move in and out of the perfs under low acceleration; there is no consequent generation of noise during pulldown<sup>2</sup>.

<sup>2</sup> Mainly the cameras offered by Éclair and Arri.

<sup>3</sup> *Aaton cameras*, Aaton Collection, Cinémathèque française. “The Aaton LTR was designed to be silent. It is driven by a brushless motor directly linked to the movement of the claw; power transmission is provided by high-tech gears—no noisy belts. As the film is flat and smooth as it travels over the aperture plate, it does not need strong back pressure to hold in place. This means that the claw can enter and exit perforations at low speed; there is no noise during the draw.”

## Lightness of the System

Deposited in 1971 by a team composed in part of former members of Éclair, it seems likely that the mechanism of this claw movement came from the éclair 16. However, it is far from being the case. Whereas in the éclair 16 cameras, there are three parts to the movement and a counter-claw, the engineers at Aaton designed a simple and precise movement that lightens the system. There is no longer a counter-claw but a single claw movement directed by the cam. The elimination of the counterclaw, replaced by the use of the pressure channel, reduces noise. To compensate for this suppression it is necessary to produce a very precise movement. In cameras, fixity is often improved by using a counter-claw, which holds the film during exposure. Meanwhile, the claw goes up to move to the next perforation and thus lowers the film again.

In Aaton cameras, this device is replaced by the use of a presseur which holds the film by pressure, during its course and when it is stationary. This trick makes it possible to achieve at the same time cost savings—with one precision mechanism less—and to lower the noise level of the operating machine, but it cannot replace the use of a counter-claw.

The absence of a counter-claw weakens the use of the single claw<sup>3</sup>. At 24 or 25 images per second, the fixity is satisfactory, which is no longer the case when the speed rises to 50 ips. An increase in speed causes fixity defects that are visible during screening. Films made with Aaton cameras are mostly shot at 24 or 25 ips: users are therefore not bothered by this lack of fixity.

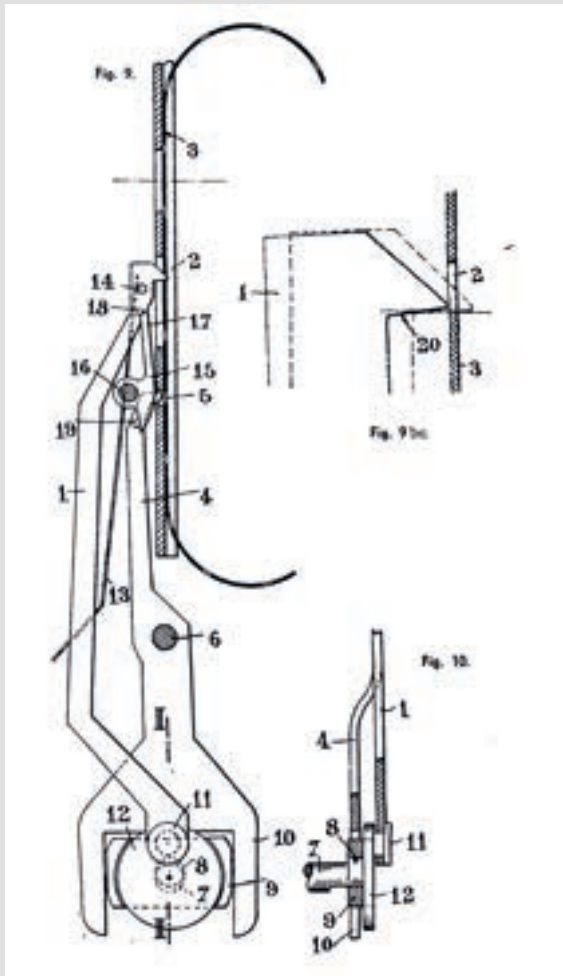

Illustration of the Eclair 16 claw in "La nouvelle caméra française Eclair 16 mm," *Bulletin de l'AFITEC*, Year 18, no 24, 1963.

the invention. Lecœur was the engineer in charge of mechanical studies at SECLER<sup>4</sup> under the direction of Beauviala, before he followed him in the creation of Aaton. Beauviala himself was surprised of the appearance of his name alone, he stated: [it] "seems impossible that Lecœur was not mentioned. He's the mechanic. It is possible that someone asked me what to do, maybe I was asked to answer a question [...]. Once I fixed the problem, a mechanic probably made the drawing, but I'm surprised I didn't put his name." One can imagine that this patent results from a collaborative work between the two engineers, as opposed to what is stated on the official document.

This first patent allowed Aaton to protect the invention which gave it the opportunity to stand out. By offering a unique response to the problems of stability and noise, the young company immediately stood out and asserted its position vis-à-vis pre-existing companies such as Éclair or Arri.

## What about the Inventor?

On the original document it is specified that Jean-Pierre Beauviala invented the mechanism, it seems however unlikely that Jacques Lecœur, who created the claw movement at Éclair, did not contribute to

<sup>4</sup> Traditionally, two claws pull the film, but small, lightweight cameras tend to eliminate the second claw to lighten the system.

<sup>5</sup> Société Éclair Etudes et Recherches.



## Visualizing Time: Chronometric Marking According to Aaton (1970–1987)

Vanessa Nicolazic

Between 1967 and 1970, Jean-Pierre Beauviala carried out, on his own<sup>1</sup>, tests to record time on film using a 16 mm Arriflex camera. At the time, he was a consulting engineer for the Éclair company where he worked on the development of the servo circuit of a motor for the Éclair 16, using a piezoelectric quartz<sup>2</sup>. More precise than the Accutron<sup>3</sup> or the HF connection—used in the early 1960s in Canada<sup>4</sup>, the United States and France—the extremely regular oscillations of the quartz made it

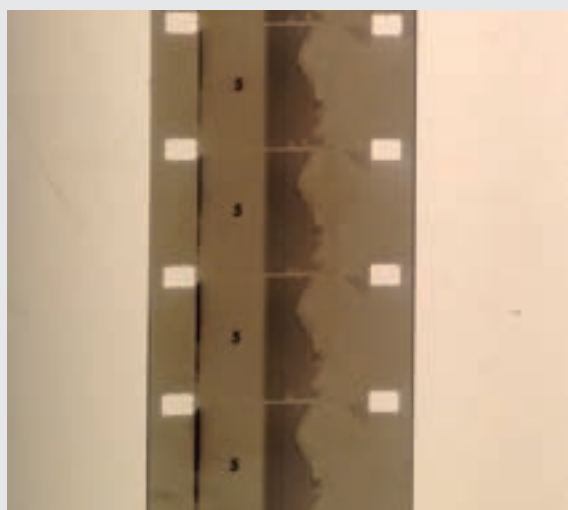

**Fig. 1 : Overprint test [1967], black and white negative, 16 mm, Aaton film collection - Fonds Aaton/La Cinémathèque française**

possible to synchronize a camera and a tape recorder to a stable reference. This electronic clock, by the making the automatic synchronization during shooting and the independence of machines particularly reliable, provided a fertile ground for the development of chronometric marking as expressed, a posteriori, by Jean-Pierre Beauviala: “The basic idea was to free the machines by synchronizing them to a universal time.”<sup>5</sup>

The Aaton film collection today contains two tests which establish the principles of what will become clear chronometric marking, an expression used for the first time by Jean-Pierre Beauviala in November 1977 for the title of an article published by Sonovision<sup>6</sup>. The first test carried out in 1967<sup>7</sup>, presents the superimposition of a number on a black and white film [Fig.1]. The reel consists of three shots, resulting from three distinct shootings: each time, the number 5 appears on the third of the frame, after two photograms and disappears two photograms before the end of the shot. In view of the various exposures, one can assume that it is a question of testing the conditions of visibility and legibility of the figure.

The second test, dated 1970, seems to pursue two objectives: to compose a number (from 0 to 7) using a combination of five segments and to write it on the edge of a colored film [Fig.2]: every twelve photograms is impressed a series of four numbers which follow one another on four photograms. The display methods, similar to calculators, are made using masks and electromagnetic diodes fixed on a channel plate, at the point where the margin of the film passes. This

<sup>1</sup> According to the words of Jean-Pierre Beauviala in an interview conducted on November 14, 2018 (unpublished) by Gilles Mouëllic and Alexia De Mari as part of the ANR Beauviatech program. It is with the same Arriflex camera that Beauviala developed the control circuit that he presented to the company Éclair. Read, on this subject: Vincent Sorrel, “L’invention de L’Éclair 16: du direct au synchrone,” 1895, n° 82, Summer 2017, pp. 107-129.

<sup>2</sup> Material used in particular in high-precision clockwork mechanisms or even for radio transceivers.

<sup>3</sup> Accutron, developed by the Bulova brand, is the acronym for ACCURACY through ELECTRONIC, or “precision through electronics.”

<sup>4</sup> At the National Film Board of Canada, following the experiments carried out by the filmmaker Michel Brault and the sound engineer Marcel Carrère on the film *Les Enfants du silence* (1962), research is carried out from 1963 on the “Time Index System, a portable multi-camera electronic clapperboard.” Vincent Bouchard, “Du Nagra au caméscope: questions de synchronisation image/son,” *Intermédialités*, n° 19, p. 128.

<sup>5</sup> Jean-Pierre Beauviala in Alain Bergala, Jean-Jacques Henry et Serge Toubiana, “Les machines de cinéma: Entretien avec Jean-Pierre Beauviala.1,” *Les Cahiers du cinéma*, February 1978, n° 285, p. 9.

<sup>6</sup> BEAUVIALA J.-P., “Le marquage chronométrique en clair,” *Sonovision*, n° 199, November 1977, p. 42-44.

<sup>7</sup> The dates were provided by Jean-Pierre Beauviala when the films were deposited at the Cinémathèque Française. Our warm thanks to Marianne Bauer who allowed us to view these tests.



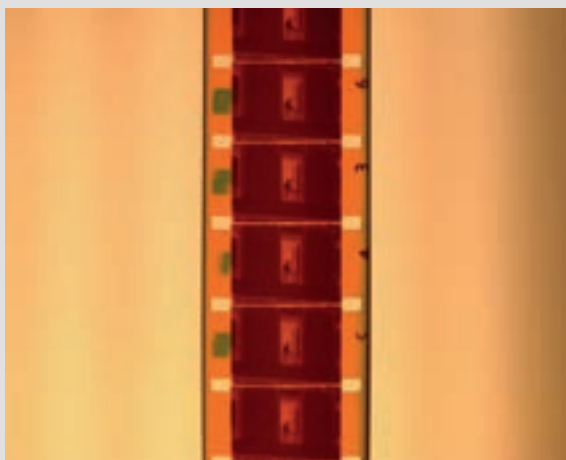

**Fig. 2 : Clear marking test [1970], color negative, 16 mm, Aaton film collection - Fonds Aaton/La Cinémathèque française**

test therefore lays the groundwork for the patent filed in the name of Jean-Pierre Beauviala in June 1977 and called “Dispositif d’affichage de chiffres par combinaison de segments de caractère<sup>8</sup>” (Device for displaying numbers by combining character segments). The principles of inscription on the film are similar. But this time, the numbers are formed using seven segments [Fig.3]. Compared to the 1970 test, this patent also tends to improve the readability made difficult by overly geometric characters. How can one explain, however, the lapse of time which separates these tests from the first patent filed in June 1977?

In several respects, the second half of the 1970s turned out to be more favorable to the continuation of these investigations which remained limited, at the

<sup>8</sup> On the INPI website, there are two very similar patents bearing the same name, and filed a few weeks apart, one on June 1st, 1977 (n° 7716682), the other on June 24, 1977 (n° 7719376). We will refer to the second filing which synthesizes the two claims present in the previous patent. “Dispositif d’affichage de chiffres par combinaison de segments de caractère” (Device for displaying numbers by combining character segments), n° 77 19376, filed on June 24, 1977 and published on January 19, 1979. Depositor: Beauviala / Trustee: Baudin.

<sup>9</sup> Jean-Pierre Beauviala in an interview we conducted on December 19, 2018 (unpublished) as part of the ANR Beauviatech program.

<sup>10</sup> This European organization was created in 1950.

end of the 1960s, by certain technical and economic constraints. Indeed, according to Beauviala, the Arriflex channel plate was undoubtedly too small: “I did not perhaps have the space to put the 7 or 8 segments.”<sup>9</sup> During its first four years of activity, the Aaton Company, founded in March 1971 and composed at the time of a small team, will concentrate all its efforts on the design of a 16 mm camera, the Aaton 7. In addition, microprocessors, widely used in electronics, are becoming more affordable for mass production. Lastly, the research carried out, concomitantly, by the European Broadcasting Union (EBU<sup>10</sup>) will give the Aaton Company the opportunity to promote its system within corporate magazines and trade fairs with professionals from the technical industry. The first two articles published by Beauviala in the *American Cinematographer*<sup>11</sup> and later in *Sonovision*, thus present the clear chronometric marking (also called “Aäton Numerals”) as being significantly more advantageous than the UER code insofar as inscriptions are readable by the human eye and thus facilitate the work of the technicians.

Faced with the needs for profitability of the audiovisual industry and the evolution of transfer techniques, the *Revue de l’UER* reported in June 1971 that a working group (G3) was working on a draft code “for the registration of time marks on image film and on soundtracks during shooting with synchronous sound and without cable.”<sup>12</sup> After various studies, the organization published in May 1976 a report<sup>13</sup>—the EBU Code for Cameras and Audio Recorders Synchronization—which defined the terms

<sup>11</sup> Jean-Pierre Beauviala, “A revolutionary approach to Time Marking on Film Sound and Video Tape,” *American Cinematographer*, vol. 58, n° 9, September 1977, p. 962–965. The aforementioned article by *Sonovision* is a translation of this.

<sup>12</sup> Anonymous, “Quarante-troisième réunion du Bureau de la Commission Technique,” *Revue de l’UER*, October 1971, n° 129, p. 235.

<sup>13</sup> The *EBU Code for Cameras and Audio Recorders Synchronization* (May 1976, 2nd edition) is the result of research carried out with the *Télédiffusion de France* (TDF) and the *Institut für Rundfunktechnik* (IRT). It followed the publication of several reports on the inscription of the code on sound recordings (in 1974 and 1975) and coincided with prospects for using the EBU code for the synchronization of films and magnetic tapes (in May 1975).

of conversion, registration and display on film of a time code (seconds, minutes, hours, months) on the basis of a binary decimal system (8 bits) readable by a synchronization table.

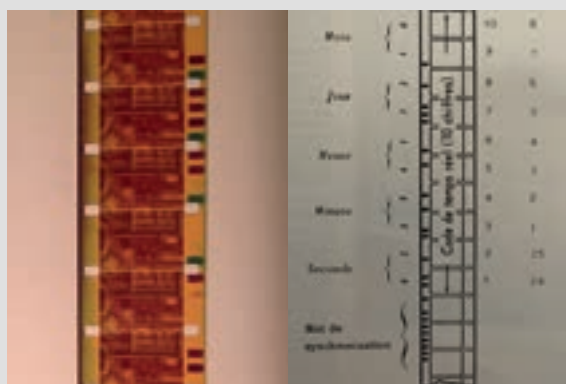

**Fig. 3 :** Test code EBU [1976], color negative, 16 mm, Aaton film base/Principle of recording the EBU time code on a 16 mm film medium, *Code de l'UER pour la synchronisation des caméras de films et des magnétophones d'enregistrement*, mai 1976 (2<sup>nd</sup> édition) - Fonds Aaton/La Cinémathèque française

microprocessor making it possible to program the time on the audio recorder and the camera, after having connected them beforehand for approximately fifteen minutes [Fig.4].



**Fig. 4 :** SPF Aaton 7 and Master Clock: the film gate has been modified to incorporate EBU code. Paul Bonnefond, "L'évolution dans les méthodes de fabrication des films de la SFP," *Cahiers de la production télévisée*, no 21, April 1978, p. 7.

As shown in a test dated 1976 that can be found in the Aaton film collection, the company performed tests with the UER code [Fig.3]. For Aaton, the implementation of this standard<sup>14</sup> provides an ideal opportunity to test its clear marking and to promote its interests among its main buyer in France: television. Thus, in 1978, the Grenoble-based company modifies the film gate of the first Aaton cameras sold to the Société Française de Production (SFP) and to TF1, to incorporate the EBU code and its clear marking system. The order<sup>15</sup> also involved another key player in the implementation of chronometric marking, the Kudelski company: the Swiss manufacturer incorporated the EBU code in the seven Nagra IVs of the SFP and collaborated with Aaton which designed four masterclocks, a device equipped with a

These implementations result in a patent filed in the name of Aaton in March 1979 and named "Camera for recording images on a mobile medium<sup>16</sup>": it defines the procedures for recording and inscription of "useful information during shooting and also their automatic analysis<sup>17</sup>" thanks to a microprocessor with memory connected to the (on/off) switch. As shown in the test of the Aaton film collection [Fig.5], the information relates respectively to the name of the production, the month, the day and the time of the shot.

To improve the EBU code<sup>18</sup> and to conquer a new market, in the 1980s the Grenoble-based company

<sup>14</sup> This report can be found in the Aaton Collection.

<sup>15</sup> According to an article in *Cahiers de la production télévisée*, the SFP began shooting with the EBU code on January 17, 1978. Paul Bonnefond, "L'évolution dans les méthodes de fabrication des films de la SFP," *Cahiers de la production télévisée*, n° 21, April 1978, p. 3-7.

<sup>16</sup> "Appareil de prise de vues pour l'enregistrement d'images sur un support mobile," n° 79 06965. Filed March 20, 1979 and published October 17, 1980. Depositor: Aaton

<sup>17</sup> *Ibid.*

<sup>18</sup> The code is written after approximately one second, the time necessary to reach stability: which makes it therefore difficult to use the process to record time on short takes.



Fig. 5 : Clear marking test [1980], color negative, 16 mm - Fonds Aaton/La Cinémathèque française

began to develop its own coding system whilst maintaining clear marking. Between 1984 and 1986, Aaton filed two additional patents to this effect. The first<sup>19</sup> defined the information coding processes in a matrix format and their inscription on the margin of the film. The second<sup>20</sup> proposes a numeral inscription improvement. Unlike the 1977 patent, the electromagnetic diodes make it possible to flash the film during its descent, and no longer when it is stationary<sup>21</sup>. At the end of the year 1984, following a contract signed with China and with Panavision<sup>22</sup>, the Aaton Company integrated its coding system—called “fdt<sup>23</sup>” and then “Aaton Code”—on the new 16 mm XTR camera in order to “force the hands<sup>24</sup>” of users. Furthermore, throughout the 1980s, the Grenoble-based company collaborated actively and closely with Telcipro<sup>25</sup>, a pioneer in film/ video transfers, as well as with the ONF to test

the reliability of the AatonCode and the Linker, a software, read the code and synchronized the transfer of sound and image rushes, it was patented in 1987<sup>26</sup>.

With these five patents filed by the Aaton Company between 1977 and 1987, chronometric marking becomes an electronic process that involves the entire technical chain, from shooting to post-production. Indeed, as Jean-Pierre Beauviala recalled, the problem laid less in “recording the time” than in “recovering it.”<sup>27</sup> Prior to the Linker, in the early 1980s, Aaton manufactured and marketed a code reading and printing device called Adage. The machine read the code on a (6.25 mm) tape and transferred it in clear, in figures, on the 16 mm tape. At the end of the 1980s, by offering double marking in code and in clear, Aaton adapts to the complementarity ►

**19**  
“Process and system for inscription of coded information on the marginal part of a perforated cinematographic film, and for reading this information,” n° 8415392, filed October 8, 1984 and published April 15, 1986. Depositor: Aaton Trustee: Cabinet Bruder.

**20**  
“Device for inscription on the marginal part of a perforated cinematographic film of information in code or in clear”, n° 8713526, filed on September 10, 1987 and published on March 31, 1989. Depositor: Aaton/ Trustee: Cabinet Bruder.

**21**  
Details provided by Jean-Pierre Beauviala in an interview on November 14, 2018, *op. cit.*

**22**  
“Annexe non simplifiée personnes morales” established by Martine Bianco for the financial year from January 1st to December 31, 1984, file “Bilan 1984”, Aaton Collection, Cinémathèque française. Our sincere thanks to Alexia De Mari for giving us this document.

**23**  
“FDT” stands for “Film Data Time.” According to Beauviala, this acronym was intended to “remove the Aatonian side” to “make it more edible to Arri”. Jean-Pierre Beauviala in an interview on November 14, 2018, *op. cit.* An internal note dated 1986 that can be found in the Aaton collection relates a meeting with Michel Thévenet, director of the young French laboratory Telcipro, and confirms a common desire to conquer the market: “we must act strongly to prevent the adoption of the FDT to take years and allow time to rush into the vacant space.” Internal note, January 28, 1986, Aaton 7 LTR box, Aaton Collection, Cinémathèque Française.

**24**  
*Ibid.*

**25**  
The Telcipro laboratory—for Tel (évision) Ci (néma) Pro (fessionnel)—was founded in 1977 by Michel Thévenet and Charly Meunier: the first films were released in April 1978. Interview we conducted with Michel Zambelli (calibrator at Telcipro) on January 2, 2017.

**26**  
“Procédé et appareil de transfert en synchronisme, sur un support d’enregistrement commun des images d’un film cinématographique et du son enregistré,” n° 8706652, deposited May 12, 1987 and published July 28, 1989. Depositor: Aaton / Trustee: Cabinet Bruder.

**27**  
Jean-Pierre Beauviala in an interview on November 14, 2018, *op. cit.*

of film and video techniques<sup>28</sup>, to the evolution of practices (calibration, transfer) and to that of machines (the new Rank Cintel and Bosch Fernsehen telecinemas).

Time marking allows the technical and audiovisual industry to increase in productivity and profitability—the automation of image-sound linkage, for example, removes certain manual operations such as footage. In the late 1980s, as professionals become reluctant to the reliability problems of this electronic process<sup>29</sup>, Aaton's clear marking enables the technician to ensure monitoring. The information becomes visible to the naked eye, the clear marking adapts to the inherent transparency of the film medium and to manual verification gestures, giving the human a leading role on mechanical operations.

#### VANESSA NICOLAZIC

**Vanessa Nicolazic is completing a thesis in film studies at the University of Rennes 2 on documentary practices and forms in television through the prism of the history of techniques and of the institution (1955-1981). Within the framework of the ANR Beauviatech and the Technès program, her research concerns the evolution of the professional 16 mm production chain and the relationship between the means of production and the creative process.**

*Vanessa Nicolazic achève une thèse en études cinématographiques à l'université Rennes 2 portant sur les pratiques et les formes documentaires à la télévision au prisme de l'histoire des techniques et de l'institution (1955-1981). Dans le cadre de l'ANR Beauviatech et du programme Technès, ses recherches concernent les évolutions de la chaîne de production professionnelle 16 mm et les rapports entre les moyens de production et les processus de création.*

**28**

The term “mixed chain,” used by the CNC as early as 1985 refers to a practice that consists of “using conventional film techniques during the production phase, and switching to electronic techniques in the post-production phase. Daniel Bréchnignac, “La chaîne de postproduction film-vidéo (I),” *Sonovision*, n° 331, November 1989, p. 62.

**29**

Indeed, in practice synchronization problems remain the subject of constant attention. Despite chronometric marking, the clap is used to compensate for the unreliability of the system, and because it gives the signal to the scene being shot, this accessory remains the guarantee for a sense of cohesion in the collective work.

## The *Single System* - The Unloved Invention

| Jean-Baptiste Massuet

The first experiments carried out by Jean-Pierre Beauviala on behalf of the Éclair company were far from his own convictions. As he puts it, the company's desire to incorporate the *single system* in the Éclair 16 and ACL magazines, a system for recording sound directly on film, appears as "a crime against cinema," or in any case against "his initial idea of cinema," which at the time relied more on chronometric marking, in other words wireless sound-image synchronization, originally based on the enslavement of the DC motor of the Arriflex camera to a quartz clock<sup>1</sup>. Although these two approaches to the sound-image relationship seem radically different, the former links sound to image, the latter rather tends to dissociate them (without, however, desynchronizing them), we are inclined to believe that they arise from, if not similar, at least related technical issues.

During an interview conducted within the framework of Beauviatech on November 14, 2018, the inventor seemed surprised by the date of the patent "*Dispositif d'affichage de chiffres par combinaison de segments de caractères*" (Device for displaying numbers by combining character segments) filed on June 1, 1977, as he remembered finding it further back, as described in the previous text by Vanessa Nicolazic. Which is hardly surprising: Indeed, in the 1960s, Beauviala had laid the foundations for his reflection on the emancipation of sound from image. Because the only solution was to get rid of the wire that connected the devices, Beauviala

sought to enslave them to a universal temporality, by means on the one hand of the quartz motor that he worked on in his home attic, and on the other hand of the principle of chronometric marking.

If the question of the marking time was therefore already a concern for the engineer who aimed at "removing the clap" for his film project on the "Villeneuve" in Grenoble, his work at Éclair was very far from this ideal, and based on the question of writing sound information directly on the film strip. The objective was to enslave sound to image, despite the difference in technical paradigm between the two (the sound signal is continuous, whereas the scrolling of the film is intermittent). Beauviala comes up with the idea of a "jumpy sound recording" to adjust to the intermittent movement of the film scrolling through the camera. It's a question of "distorting the sound, so that it matches the distortion of the speed of the camera."<sup>2</sup> Beauviala considers that this system has "nothing to do" with time marking, we however, are inclined to believe that this observation is above all of the result of practical and aesthetic considerations, and that each of these inventions offers different solutions to a relatively similar technical problem. The fact that Éclair entrusted Beauviala with the problem of the *single system* on the basis of his experiments with the quartz motor and chronometric marking undoubtedly supports this intuition.

The *single system* is based on three successive patents: the "*Registre à décalage*" (Shift register) issued on February 19, 1971, the "*Dispositif d'enregistrement et de lecture évoluant dans le temps*"<sup>3</sup> (Recording and reading device evolving over time), issued on February 26 of the same year,

<sup>1</sup> Jean-Pierre BEAUVIALA In Alain BERGALA, Jean-Jacques HENRY et Serge TOUBIANA, "Les machines de cinéma: entretien avec Jean-Pierre Beauviala.1," *Cahiers du cinéma*, Februray 1978, n° 285, p. 9.

<sup>2</sup> *Idem*.

<sup>3</sup> From an interview with Jean-Pierre Beauviala conducted as part of the Beauviatech program on November 14, 2018, in the presence of Caroline Champetier, Gilles Mouëllic and Alexia de Mari.

<sup>4</sup> BEAUVIALA Jean-Pierre, "Registre à décalage" (Shift register), Patent n° 2044562, published on February 19, 1971.

<sup>5</sup> BEAUVIALA Jean-Pierre, "Dispositif d'enregistrement et de lecture évoluant dans le temps" (Recording and reading device evolving over time), Patent n° 2045141, published on February 26, 1971.

and finally the one entitled “*Perfectionnements aux appareils de prise de vue et de projection de films cinématographiques*”<sup>6</sup> (Improvements to cinematographic film shooting and projection devices) issued on April 9, 1971. Each patent is based on the previous one. The first describes a digital sound encoding system to turn an analog signal into information encoded in binary language; the second describes the principle of discontinuous recording of the sound signal, and, on the basis of the first patent, how information will be stored before being reproduced analogically; the third, finally, applies these tools to cameras and screening, describing where the encoded sound information is stored, namely on the side track of the film.

We understand that for Beauviala time marking is the exact opposite of the *single system*. As he explained it himself: “One [system] records sound and image on independent supports which must then be relinked with time marking; the other records sound and image on the same medium without time marking.”<sup>7</sup> The last two stages of the *single system* patent, clearly echo, at least partially, the initial problematic that led to time marking. Indeed, the *single system* aims not only at recording the sound information on the film tape but also at synchronizing this information with the image. In other words, the questions raised by Beauviala with this invention converge with chronometric marking on one aspect: the problem of the perfect synchronization of a continuous signal with intermittent information.

Although time marking and the single system pave the way for two different paths in terms of practice, technique, aesthetics, and even more so ideology as regards the production of moving images at

the time, they nevertheless stem from relatively close engineering issues (at least from a certain point of view), which appear to be at the heart of the technological reflections that emerge in the 1960s on the threshold of the emergence of direct cinema, and of the work of filmmakers like Donn Alan Pennebaker or Albert and David Maysles. In this respect, Beauviala’s perception of the *single system* reveals his conception of engineering, which is fundamentally linked to his artistic eye that nourishes and directs his work, and to the politicized vision of cinema that the inventor developed from the start—including with respect to those of his inventions that he hardly appreciated.

###### 6

BEAUVIALA Jean-Pierre, “Perfectionnements aux appareils de prise de vue et de projection de films cinématographiques” (Improvements to cinematographic film shooting and projection devices), Patent n° 2051977, published on April 9, 1971.

###### 7

Interview with Jean-Pierre Beauviala within the framework of Beauviatech, *op. cit.*

## La Paluche, “The Eye at Your Fingertips”<sup>1</sup>

| Hélène Fleckinger

“Paluche” is the nickname, taken from Parisian slang, of a black and white miniature video camera with unique ergonomics that was designed by Jean-Pierre Beauviala, and marketed under the name Aaton 30 and which exists in different versions. Result of the video control planned on the Aaton 7 camera, autonomous from the 16 mm film system, this “legendary camera”<sup>2</sup> was adapted to the hand in a tubular form, and tested from 1974 onwards. 20 centimeters long, it can be held like a microphone or an electric torch and weighs 300 grams. On the INPI website, a unique patent relates to the Paluche, although the name does not appear: no author, filed on March 3, 1976, it involves a “portable installation for television shots.”<sup>3</sup> Barely technical, primarily legal, this patent offers a brief two-and-a-half-page description, followed by a page of largely redundant claims and two diagrams.

The basic technical device is described as consisting of four elements connected by cables: a small-diameter (approximately 37 mm) tubular video head containing an 18 mm vidicon tube and capable of receiving different lenses with an adapter; a control unit incorporating the various electronic circuits; an electrical energy source; a screen monitor to observe the captured images. The patent mentions three main areas of use of the Paluche: “cinematic” (primary use as “extra viewfinder, flicker free, in a film camera or as a video sensor in an editing table”), “reportage” (appropriation allowing the camera to be “manipulated like a microphone at arm’s length”) and finally “industrial or medical” (in situations

requiring “compactness and reliability”). Compared to the heavy and unwieldy shoulder-mounted television cameras, this new “portable camera installation” is touted as advantageous because it offers “great flexibility of handling” thanks to its smallness and low weight, as well as the possibility to “easily and quickly steer the video head towards any point.” Both drawings illustrate how the different elements that make up the Paluche can be arranged and worn by the operator on a belt around the waist. A variant also suggests hanging the monitor around the neck.

This patent, which focuses on shooting, does not specifically address sound or image recording. The situation that is depicted is that of a minimal shooting with a television signal transmitter, but two other scenarios may arise: shooting with a VCR worn



Video head held. **Éric Guichard - Fonds Aaton/La Cinémathèque française**

in the back (the heaviness of this device fuels “the lightweight video joke: the apprentice cosmonaut”) or in a studio with multiple cameras and recorder. ►

<sup>1</sup> FIESCHI J.-A., “Point de vue sur un troisième œil. Nouveaux cinémas,” *Le Monde*, January 29, 1976.

<sup>2</sup> FARGIER J.-P., “Une caméra légendaire,” *Le Monde*, February 27, 1981.

<sup>3</sup> Patent n° FR2344194, published on October 7, 1977, available online: <https://data.inpi.fr/brevets/FR2344194#FR2344194> (accessed on September 1st 2020). The following quotes are extracts from the patent.

<sup>4</sup> BERGALA A., HENRY J.-J. and TOUBIANA S., “Aux deux bouts de la chaîne (entretien avec Jean-Pierre Beauviala),” *Cahiers du cinéma*, n° 287, April 1978, p. 11.



Although the major assets that will make the Paluche famous are listed in this patent (reduced clutter and lightness of the basic elements, exceptional mobility and maneuverability of the video head, wide choice of shooting angles), these are further developed in Aaton's later commercial documentation, which also highlights its low energy consumption, a definition and sensitivity far superior to other video cameras of the time, the great stability of the electronic circuits as well as the transformation of the shooting conditions and the relationship between those who film and those who are being filmed in the case of the reportage<sup>5</sup>.

The advertising leaflets also detail the existence of three analytical heads each with their own specificity (corresponding to the three types of use cited), two control boxes and two target monitors (the KWA).

Jean-Pierre Beauviala showed little interest in analog video: "It didn't make Aaton's heart beat,<sup>6</sup>" he said. Although he liked, with a disconcerting smile, to relativize the invention of the Paluche: "It was a good idea, the kind of idea that comes in the morning while you're dipping your tartine in your café crème," he admitted, however, that it had become a very special tool for investigating the world, and the origin of new aesthetic experiments<sup>8</sup>. The great innovation of the Aaton 30 video system, which the patent sketches without explicitly formulating it, ultimately rests on the separation between the camera lens and the control of the frame, in other words, the optical viewfinder: the Paluche separates the electronic eye from the physical eye of the framer. And this is precisely what

Jean-André Fieschi, the "first individual touched by grace,<sup>9</sup>" points out: "It sweeps, it picks up. An eye at your fingertips, literally. Strange, new impression, like an organ transplantation or duplication, when the image materializes.<sup>10</sup>"

#### HÉLÈNE FLECKINGER

**Historienne du cinéma et de la vidéo, Hélène Fleckinger est maîtresse de conférences à l'Université Paris 8 Vincennes Saint-Denis. Spécialiste des pratiques féministes du cinéma et de la « vidéo des premiers temps », elle s'intéresse également à l'apport des humanités numériques à l'écriture de l'histoire du cinéma. Elle a récemment dirigé, avec Kira Kitsopanidou et Sébastien Layerle, l'ouvrage *Métiers et techniques du cinéma et de l'audiovisuel : Sources, terrains, méthodes* (Peter Lang, 2020).**

*Historian of cinema and video, Hélène Fleckinger is a lecturer at University Paris 8 Vincennes Saint-Denis. A specialist in feminist practices in cinema and "early ages of video," she is also interested in the contribution of digital humanities to the writing of film history. With Kira Kitsopanidou and Sébastien Layerle, she recently directed the book *Métiers et techniques du cinéma et de l'audiovisuel : Sources, terrains, méthodes* (Peter Lang, 2020).*

<sup>5</sup> See "Aaton Vidéo. Aujourd'hui tout ce que vous voulez savoir sur le système Vidéo Aaton," undated. Archives de la Cinémathèque française, Aaton Collection.

<sup>6</sup> FLECKINGER H. and DE MARI A., Entretien inédit avec Jean-Pierre Beauviala, Paris, December 14, 2018, as part of the ANR Beauviatche Program.

<sup>7</sup> BERGALA A., HENRY J.-J., TOUBIANA S. and ROSENBERG S., "La sortie des usines Aaton (entretien avec Jean-Pierre Beauviala. 2)," *Cahiers du cinéma*, n° 286, March 1978, p. 13.

<sup>8</sup> See Beauviala's speech during the "Vidéo des premiers temps" seminar session dedicated to François Pain and to the la Paluche video experiments, January 12, 2015, at the BNF: <https://earlyvideo.hypotheses.org/284>; and DUGUET A.-M., *Vidéo, la mémoire au poing*, Paris, Hachette, 1981, p. 165-174.

<sup>9</sup> BERGALA A., HENRY J.-J., TOUBIANA S. and ROSENBERG S., "La sortie des usines Aaton (entretien avec Jean-Pierre Beauviala. 2)," op. cit., p. 14.

<sup>10</sup> FIESCHI J.-A., *loc. cit.*



## From the 8-35 to the Aaton 35

Vanessa Nicolazic  
Vincent Sorrel

The 8-35 camera was never marketed, only one prototype manufactured between April 1978 and June 1979<sup>1</sup> exists. Yet, in 1981, the Aaton Company communicated on this device in the *Cahiers du cinéma*. One of the many advertisements for Aaton published in the review presents, on the left page, a collage consisting of a painting and a check for 4,812 francs written by Sonimage and payable to Aaton. It was written by the hand of Godard who added in the margin, “Encore payer toujours.” On the right



Fig. 1 : Cahier du cinéma n°321

page, a text: “This composition was made by Jean-Luc Godard on the occasion of an invoice payment.” This document is published because the first faithful representation of the Aäton 8-35 mm camera can

be seen in the arms of the child. Godard is trying to prevent the project he started from falling to his feet, unless it is Aäton<sup>2</sup> exhausted of carrying out the long and difficult experimentations of this 35 mm camera<sup>3</sup>. It is difficult to quantify how much the filmmaker really invested in the realization of the prototype of the 8.35, probably 100,000 francs.<sup>4</sup> In interviews with Godard published in 1983 in the *Cahiers du cinéma* under the title *Genèse d'une caméra. Episode 1 & 2*, Jean-Pierre Beauviala estimates a much higher cost for the development of the Aaton 35:

“The 8.35 camera, the one you used on *Sauve qui peut*, it took two years to make it. It cost 800,000 francs. The following one, the Aaton 35, after three years, we are at 4 million and it is not yet finished.<sup>5</sup>”

It took 10 years and several prototypes for Aaton to market, in March 1989, a new camera, the Aaton 35. In the exchange with Godard which sealed the fate of the Godard prototype, Jean-Pierre Beauviala considers that the 8.35 was a “stillborn<sup>6</sup>” camera and that everything had to be started over again to design the Aaton 35. On December 7, 1979, the company obtains a financing of 950,600 francs from the CNC’s Commission of technical industries for the “Realization of a silent and lightweight 35 mm high quality cinematographic camera” whose announced cost is 3,426,500 francs. The project was to make a 35 mm camera with a 120-meter magazine that would weigh only 6.5 kilos: “Benefiting from the remarkable electronic know-how of the firm, the prototype of the 35 camera is already currently used by JL Godard as a backup camera on the shooting of his film *Sauve qui* ▶

<sup>1</sup> The prototype of the 8-35 is kept in the Cinémathèque française. The anecdote of Bruno Carrière which is published in this volume suggests that a second model was under construction in May 1979 when the Quebec filmmaker visited the Aaton factory.

<sup>2</sup> At the time, the company used the umlaut on the second letter A.

<sup>3</sup> *Cahiers du cinéma*, n° 321, March 1981. Thanks to Thomas Godefroy.

<sup>4</sup> For his return to cinema, Godard had decided to devote a part of the budget of his three upcoming feature films, *Sauve qui peut (la vie)*, *Passion*, and *Prénom Carmen*, to the development of this camera.

<sup>5</sup> “Genèse d'une caméra. 1er épisode,” *Cahiers du cinéma*, n° 348-349, June-July 1983, p. 94-111. The exchange between Jean-Luc Godard and Jean-Pierre Beauviala is organized by Alain Bergala in the *Cahiers du cinéma* offices, in the presence of Jean-Bernard Menoud, who was Godard’s assistant at the time.

<sup>6</sup> “Genèse d'une caméra. 2ème épisode,” *Cahiers du cinéma*, n° 350, August 1983, p. 45-61. Alain Bergala and Serge Toubiana with the participation of collaborators who were working with Godard at the time: Renato Berta, Romain Goupil and Vincent Blanchet.

*peut la vie* in addition to an Arriflex 35 mm, because the 5 kg prototype has for the moment a magazine of only 60 meters.<sup>7</sup>

The grant application notifies that Aaton wishes to compete with Arriflex with a camera that is lighter (the document specifies that the Arriflex weighs 15 kilos), silent (33 dB without *blimp* and less than 30 with) and at a price of 120,000 francs, and 25,000 francs for video replay. The grant application depends on the success of Aaton, founded in 1971, that manufactures and markets a 16 mm camera model since 1974. “The project is well advanced and the prototype is currently being used on a shooting.” The adventure with Godard, despite its bad ending in the *Cahiers du cinéma*, serves as an argument to obtain fundings, as the 1979 shooting of *Sauve qui peut (la vie)* marks the return of the filmmaker to the feature film format. Why is the 8.35 not the prototype of the Aaton 35? For time and cost issues, but also to meet the requirements of a small and simple camera, Godard had not insisted on the design of a silent camera to, he stated, “listen to people rather hear them.<sup>8</sup>” The 8.35 “makes music<sup>9</sup>” whilst camera noise becomes a constraint for mass-production cameras. Also, according to Jean-Pierre Beauviala, “nobody wants 60 meter magazines.<sup>10</sup>” The profession expects 120 magazines to film a little more than 4 minutes in 35 mm. The difficulty of dialoging between the technical and the formal aspects of the invention, represented here by Beauviala and Godard, undoubtedly resides in the impossibility, in terms of the market, of producing a camera for a filmmaker and the specificity of his gesture. The comparison of the design of the two cameras shows that the industrial objective involves being able to adapt to

a wide spectrum of shooting situations, because the camera is mainly intended for rental companies. Moreover, it must, as are the 16 mm cameras developed by the small Grenoble-based company, be a technological product, which offers an electronic time code and video playback, which is not the case with the 8.35 that Godard wanted simple, to make simple images<sup>11</sup>.

After the funding was received, Jean-Pierre Beauviala took over the design process of the camera<sup>12</sup> to produce a first version which appears on a 1984 brochure. The camera’s name is still 8.35 and the technical specifications describe a two-motor camera: specificity that constitutes the sole (non-patented) innovation of the 8.35, which is also what condemned the 8-35 on the set of *Passion* (1982) when the cold hit the factory prototype which was not yet tropicalized. Raoul Coutard, who arrived on the set during an outdoor shooting refused to use the camera, even though on the following days Jean-Pierre Beauviala had installed resistors to keep the most sensitive parts warm and reprogramed the electronics of the camera<sup>13</sup>. What remained of the misfortune of the 8-35 was the use of resistors, in particular to heat the claw of the Aaton 35<sup>14</sup>, whereas the idea which consisted of synchronizing two motors to multiply the rotation mechanism was lost in the dispute. There is a second small motor on one side of the Aaton 35, but it is not synchronized to the main motor as was the case for the 8-35 and it operates with direct current to pull—continuously—the film so that it winds better on the receiving reel. Electromagnets provide power for the winding of the axis without weighing down the magazine, with a motor which is placed on the side of the camera.

**cette note n'est pas dans la trad** **7** Demande de financement à la commission des industries techniques. Archives Nationales, site de Pierrefitte, Fonds des industries techniques, dossier n°19970544/15.

**8** In the brochure dedicated to the 8.35, Aaton announced 35 dB for the prototype (Aaton Collection, Cinémathèque de Grenoble).

**9** In *Prénom Carmen*, Jean-Luc Godard plays the role of Uncle Jean, a filmmaker that his niece comes to visit at the hospital with a film project. In the scene, Godard is seated on the floor with a radio cassette player on his shoulder, and he offers to lend her his new musical camera.

**10** *Genèse d'une caméra. Episode 1, Op. Cit.*

**11** SORREL Vincent, “L’instant fatal où la lame se brise,” In Antoine DE BAECQUE and Gilles MOUËLLIC (dir.), *Godard/Machines*, Crisnée, Yellow Now, 2020, p. 30-55.

**12** The 8.35 was designed by Jacques Lecoeur and built by prototypist Robert Leroux.

**13** RYFFEL Hugues, “À la recherche d’une caméra qui fait des images...” In Antoine DE BAECQUE et Gilles MOUËLLIC (dir.), *Godard/Machines*, Crisnée, Yellow Now, 2020, p. 57-73.

**14** This precaution prevents dilations which would modify the stillness or the noise of the camera.

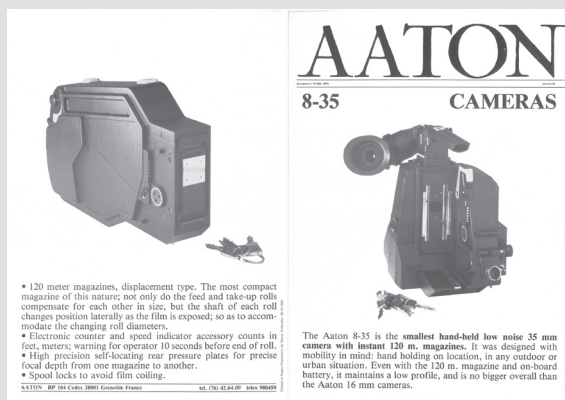

Fig. 2 : Brochure 8-35. Cinémathèque de Grenoble

As of this 1984 version, the 60-meter magazine is replaced by a standard 120-meter magazine which meets professional expectations<sup>15</sup>. The semi-transparent blade, which was the subject of much debate among the technicians who worked with Godard, was replaced by a shutter with a rotating mirror tilted at 50 degrees and which opened at 180°. To keep the concept of a compact camera while doubling the capacity of the magazine, Aaton turned to a well-known system, the compensator. The system, which already existed on other cameras, involves placing a motor inside the magazine to move the axis as the supply reel empties itself and the receiver fills up: which presents the disadvantage of making the magazine—which also needs to be supplied—heavier. The patent filed on April 28, 1987, under “*Caméra cinématographique utilisant des magasins de film interchangeables à déplacement des axes des bobines de film débitrice et réceptrice*” (Cinematographic camera using interchangeable film magazines with motion of the axes of the feed and receive film reels), invented by Jean-Pierre Beauviala (Patent n° 8706000), introduces

<sup>15</sup> The 120 meter magazines allow, in 35mm, to film a little more than 4 minutes (instead of 2 minutes with the 8-35).

<sup>16</sup> The pressure at the bottom of the presser must always be stronger than where the image is formed.

<sup>17</sup> Jean-Pierre Beauviala specified: “There has to be a different behavior of the pressure on the film at the location of the film gate. We made a block in which the film is gently squeezed at the film gate, and at the claw, it is no longer squeezed at all. There is the space for the movement of the claw, but no pressure. So it’s more complex, the number of parts, etc.”, Jean-Pierre Beauviala, interview conducted by Vanessa Nicolazic as part of the Beauviattech project, supported by the ANR, December 19, 2018.

<sup>18</sup> The electromagnets had already been used to drive the magazine of the 8-35: they make it possible to reduce the mechanical transmission components, the energy needed in order to drive them, and the noise they generate by friction. The design of the Aaton 35 largely included this technique (except for the presser and this, in spite of what the patent indicates).

<sup>19</sup> Pierre Michoud is now responsible for sales and external relations services at Aaton Digital, run by Jacques Delacoux.

the use of gravity and of an electromagnetic system to move the axis, without a motor.

The photography published on the 1984 brochure presents a new design, a viewfinder in the same line as the Aaton 16 that allows to move the hand-held camera back, but the mechanical part, the presser, remains identical to that of the Godard prototype. (Ill.03). As the versions progressed (6.35, then LS, LR and LRX with the two prototypes of June 1987 and July 1987 which really foreshadow the Aaton 35), the mechanical system of the camera was perfected. To begin with, the Aaton 35 was equipped with a side presser which did not exist on the 8-35 and the film guide system resulted in two patents. The first patent was filed on February 24, 1986 (n° 860292), the second one on May 13, 1987 (n° 87 06718). Both have the name “*Dispositif de guidage d’un film dans une caméra cinématographique*” (Device for guiding a film in a cinematographic camera) and the declared inventor is Jean-Pierre Beauviala. The system adopted for the Aaton 35 is different from that of the 8.35 which is in two (lower and upper) parts<sup>16</sup>. The system of the Aaton 35 is made up of a main block with, inside it, an element that exactly matches the gate in order to exert a much softer pressure<sup>17</sup>.

The first patent specifies the use of a magnetic field generator which would allow removing mechanical elements, which generate noise, in order to exert pressure on the film at the time of exposure, and to remove it when the film moves. The second patent adds the use of piezoelectric materials to which an electric voltage generator is connected in order to ensure different pressures. However, this use of electromagnets has never been carried out on the Aaton 35<sup>18</sup>. Pierre Michoud<sup>19</sup>, who was in charge of the maintenance

and therefore of the adjustments of these 35 mm cameras at the Aaton customer service for many years, confirmed that the pressure was simply provided by four helical springs placed at each corner of the image presser, as on the Aaton 16. The details provided by the mechanic confronted with experience prompts researchers to be cautious when it comes to understanding an innovation: “Patents are there to protect you from the inventions of competitors. It’s an idea that you patent, but an idea that may not be immediately applicable. Simply, it could be.”<sup>20</sup>

The advertisement for the next version of the prototype, the 6-35, presents a camera of “extraordinary fixity,” with a low inertia claw, adjustable horizontally and vertically, called “Saphir.” The commercial document states that the system was patented but there is no patent filed at that time for a claw system for the Aaton 35. If the drive system has been re-envisioned (the claw, to the left of the channel on the 8.35, is to the right on the Aaton 35), Aaton has adapted the claw principle that the company had developed for the 16 mm: the vertical and horizontal adjustment of the pitch improves the fixity and the noise made by the claw when it penetrates the perforation<sup>21</sup>. The design of the Aaton 35 is interesting because it reveals that a mechanical camera could be improved technically in the 1980s thanks to electronics, but also by extending the adjustment options. The precision of the image and the silence of the camera depended on adjustments of the claw such as that of the tension of the image presser and the parallelism of the channel plate. Only the human hand can, with the help of measuring devices (a load cell), tools and gauges, but above all by eye and ear, make adjustments to the ready

micron<sup>22</sup>. “A load cell is used to check the tension of the springs. If the tension is unsatisfactory, the spring can simply slightly be reshaped (by hand) to reach the desired tension,” as stipulated in the maintenance manual of the Aaton 35 III (1996). The silence of the camera depends on the quality of these adjustments, and everything has been redesigned with rollers mounted with “Teflon or peelable<sup>23</sup>” washers and isolated by rubbers to make the drive of the film as silent as possible.

The comparative study of the devices reveals that the devices developed for the Aaton 35 in order to ensure a good fixity of the image are much more sophisticated than the presser of the 8-35 which remains sketchy. Yet, the analysis of the tests carried out by William Lubtchansky in 1979<sup>24</sup> show us that the fixity of the camera is good. Renato Berta, who worked on *Sauve qui peut (la vie)* in collaboration with William Lubtchansky, gave us what could be a rational explanation: the 8.35, intended to make pieces of films, is equipped with a 60-meter



**Fig. 3 : The 8-35 and the Aaton 35. Photography: Vincent Sorrel - Conservatoire des techniques de la Cinémathèque française.**

**20** Interview of the author with Pierre Michoud, September 28, 2020.

**21** This patent was filed on November 4, 1971.

**22** The 1996 Aaton 35 III Service Manual indicates that “the parallelism must be checked at the four corners of the exposure window. The maximum deviation is of 2/100th between two sides”. OR: “To adjust the feed friction of the magazine, use tool 0920092 and a dynamometer. (0.50 grams) is the correct setting for friction and 30 grams + 0/+ 5gr.”

**23** Aaton 35 III Service Manual. A peelable washer is obtained by stacking metal sheets glued together, the friction parts made out of Teflon resist temperature changes and strong mechanical stresses.

**24** William Lubtchansky carried out tests between May 16 and May 22, 1979, in Rolle, then in Paris, assisted by Caroline Champetier. The stillness was checked by shooting a mire de Foucault and exterior shots and comparing the stillness of the 8.35 with that of the Arri BL. We thank Marianne Bauer of the Cinémathèque française for allowing us to examine the film.

magazine. Ensuring the fixity at the exact moment of the imprint on the film represents a different degree of complexity according to if the mechanism has to drive a 60-meter magazine, or the 120 meters of the standard magazine of the Aaton 35. The weight and the inertia are different with twice more film, despite the fact that the alternating scroll limits these parameters. The small 8.35 is a fixed camera because the drive system is consistent with the size of the magazine. Above all, it meets the technical requirements of a time which was different from when the Aaton 35 was marketed, ten years later. The lightweight camera, which allows shooting in 35 and Super 35, is often used as a second camera and must *match* with the more advanced models<sup>25</sup>.

Handling both cameras, one discovers two very different technical objects<sup>26</sup>. Even though it's compact, balanced over the shoulder, and very maneuverable compared to other 35 mm cameras, the Aaton 35 is heavier and wider than the 8-35 because it includes a lot of improvements. The Aaton 35 weighs 7 1/2 kilos (battery and film included), as compared to the 5 kilos of the 8.35 and its 60-meter magazine. In its simplicity, the 8-35 is a technical object that has achieved its consistency. "Carved in rock and glass," as Jean-Pierre Beauviala said, it is a very discreet, narrow, thin camera. Smaller than an Aaton 16, its lightness allows it to be held in the hand, to be reactive in the action.

This maneuverability was confirmed to us by Renato Berta<sup>27</sup>. While he was preparing the shooting of Patrice Chéreau's film, *L'Homme blessé* (1983) in the Gare du Nord in Paris, the director of photography decided to take Jean-Pierre Beauviala at his word when he said that the 8.35 was made to shoot in railway stations because of its maneuverability and



**Fig. 4 : Electromagnetic system for the travel of the axes of the compensator magazine of the Aaton 35. Sketch by Pierre Michoud - Photography: Eric Hurtado.**

the fact that the noise would be covered by the hubbub. The 8.35 served as the main camera for the opening sequence of the film and proved to be perfectly suited to shooting discreetly, slipping behind the character played by Jean-Luc Anglade among the crowd in the station that had remained open. The moving camera perfectly followed the movements of the character and of the extras. Berta doesn't remember any particular difficulties for focusing or slipping between moving bodies. As it was not possible to light the concourse, the first sensitive color films (Fuji 200 ASA) enhanced the strong points of the prototype by offering the possibility of shooting a sequence of images with an extended depth of field and great modernity. ▶

**25**

The camera was quickly improved with the Aaton 35 II (1992) and the Aaton 35 III (1993).

**26**

We thank Laurent Mannoni for giving us the possibility to manipulate the camera, which again confirms the importance of research by the Conservatory of Techniques of the Cinémathèque française.

**27**

Interview with the authors, February 17, 2019.

## VINCENT SORREL

Vincent Sorrel is a filmmaker and lecturer in artistic creation at the University Grenoble Alpes. His work on technique is seen both as an imaginary shared between inventors and filmmakers, and as a medium linking tool making and filmmaking by intervening on questions of writing and documentary filmmaking. This research, both theoretical and artistic, is also developed through the making of films on the cinematographic gestures of Artavazd Pelechian or Vittorio de Seta. He participates in the ANR Beauviatech supported by the University of Rennes 2 and collaborates in the Technès international research partnership on film techniques and technologies.

*Vincent Sorrel est cinéaste et maître de conférences en Création artistique à l'Université Grenoble Alpes. Son travail sur la technique est envisagé à la fois comme un imaginaire partagé entre les inventeurs et les cinéastes, et comme un milieu reliant la fabrication des outils et la pratique filmique en intervenant sur des questions d'écriture et de réalisation documentaire. Cette recherche à la fois théorique et artistique est développée également à travers la réalisation de films sur les gestes cinématographiques d'Artavazd Pelechian ou de Vittorio de Seta. Il participe à l'ANR Beauviatech porté par l'Université de Rennes 2 et collabore au partenariat international de recherche Technès sur les techniques et les technologies du cinéma.*





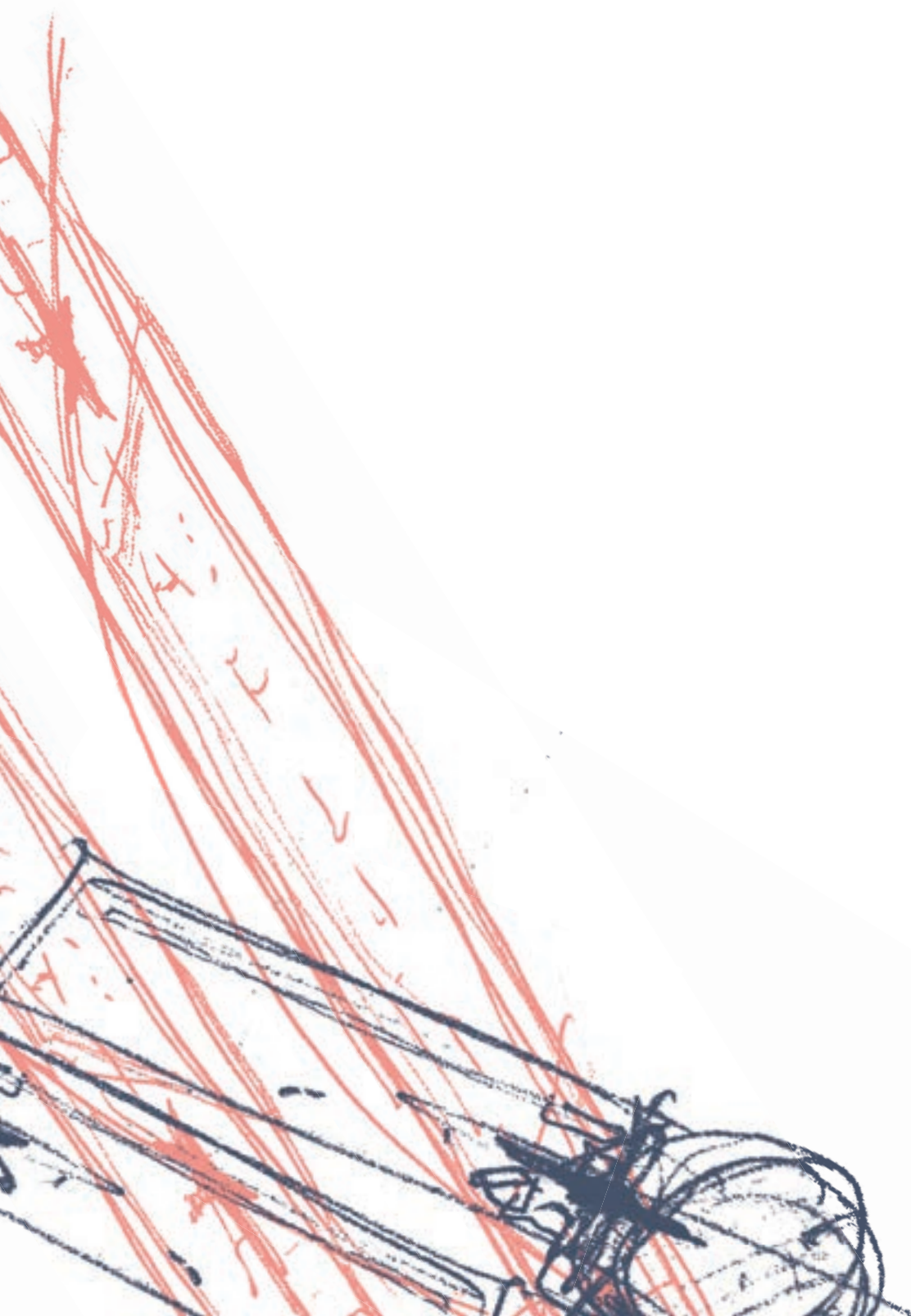



# 3. The Aaton Company

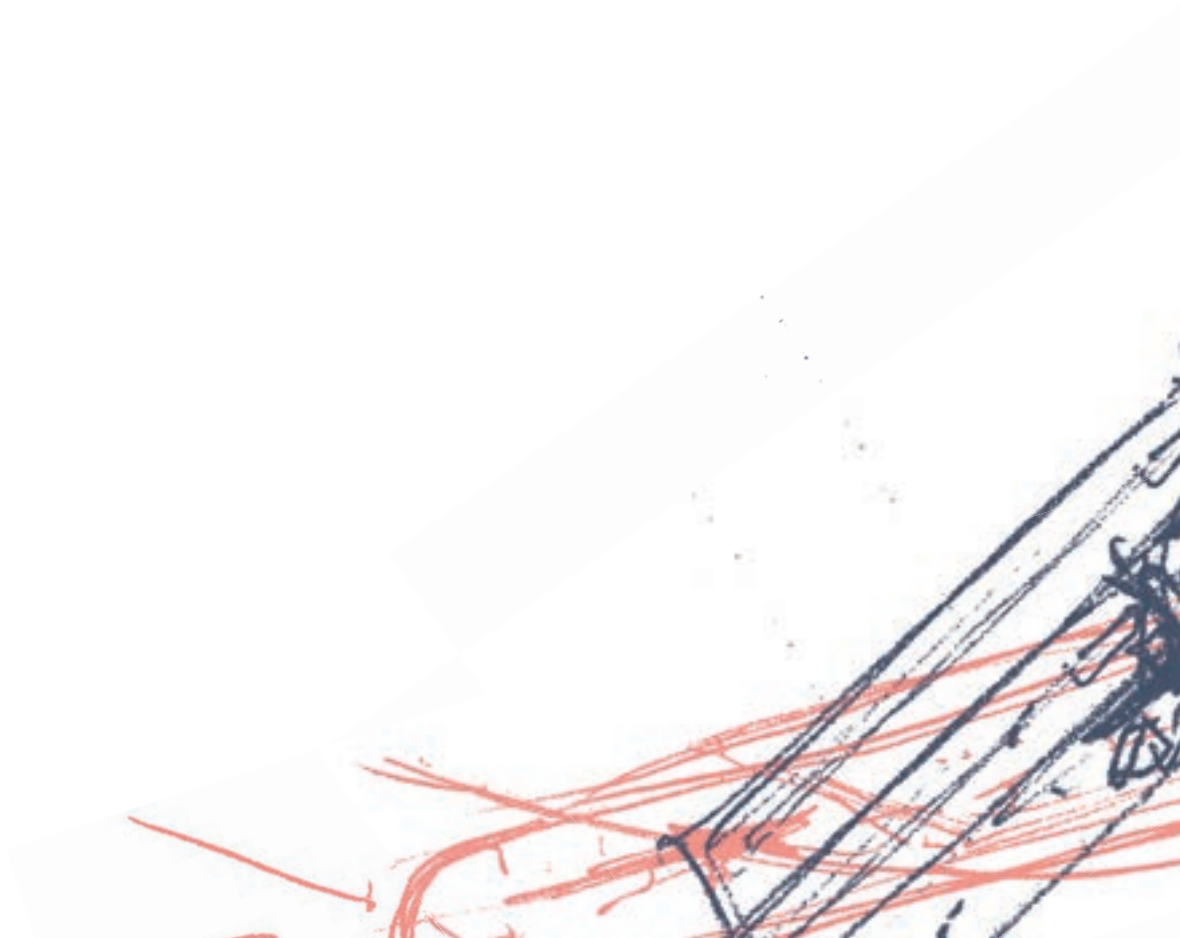



## The Visit to Grenoble. The Aaton Factory Manufactures Images and Sounds<sup>1</sup>

Vincent Sorrel  
Nicolas Tixier



The Aaton camera factory is a place that embraces the imaginary of a small cinema factory, to which Jean-Luc Godard was sensitive when he moved to Grenoble to order a prototype camera made to his measure. This 8.35 camera adventure represented the fantasy of a dialogue between an industrialist and a filmmaker, Jean-Pierre Beauviala and Jean-Luc Godard, for which the critics of *Cahiers du cinéma*, Alain Bergala and Serge Toubiana, traveled to Grenoble.

The first vocation of Jean-Pierre Beauviala was architecture: he expressed it through the design of technical objects (cameras, sound recorder) but also of spaces: the apartments on rue Carnot and Place Notre-Dame, the house in Mens and the

film factory located in the historic city center of Grenoble. To go from one workshop to another, the *Aatoniens* had to cross the rue de la Paix. The factory expanded gradually, in a very organic way, by annexing old craftsmen's workshops with windows where you could glimpse the manufacturing process. This street scene has largely illustrated two articles published in the *Cahiers du cinéma* under the titles *Genèse d'une caméra. Episode 1 & 2*. Although these interviews tell the story of the failure of the alliance between Godard and Beauviala, a movement sparked. Many filmmakers made the trip: the place, which had become legendary, represented, with its small company artisanal dimension, the possibility of making cinema differently. The stakes of creation were never far from the factory which was above all a design office and an assembly workshop partially visible from the street: the thousands of parts that make up a camera were manufactured by suppliers from all over the world. , but "the film factory" represented, with the advertisements, the mise en scène of a dialogue between filmmakers and industrialists.

Jean-Pierre Beauviala was very attached to its location in the city center and its position outside Paris: the advertisements for Aaton published in the *Cahiers du cinéma* extended the vitrines of the factory whose transparency reveals the craftsmanship in the same way as the *design* of Aaton products reveals their internal structure. Some of the advertisements are an invitation to visit the factory to talk about cinema, but also to discover the mountains or admire a Bonnard at the Grenoble Museum. Each visit is an opportunity to position the "view" of the rue de La Paix on the international stage. ►

<sup>1</sup> This research work sees the factory as a creative environment that produces cameras and images. It is the result of interdisciplinary work carried out in Grenoble (Liit & arts and AAU\_Cresson-Université Grenoble-Alpes) and is part of the ANR Scanea (Sagot-Duvauroux, Charles Ambrosino, Universities of Angers and Grenoble-Alpes) and Beauviatch (Jean-Baptiste Massuet and Gilles Mouëllic, Université Rennes 2). vincent.sorrel@univ-grenoble-alpes.fr & nicolas.tixier@grenoble.archi.fr

You made the trip. We would like to collect the stories of your visits to Grenoble to form a book on the aesthetic and sensitive dimensions of the place, as the starting point for reflections on cinema, on the relationships between manufacturers and filmmakers, and on the relationships between devices and films. In these texts, which may come in very free form, we would like you to describe these encounters in detail, the discussions and the rituals that took place during these visits with the walks up the rue Bayard to the Place Notre-Dame and the Le Glacier brewery, the tonneau de Diogène or, closer, the pizzeria on rue Auguste Gaché. You may have kept sketches, taken photos, shot images ... which document these “ambiances.” Whether in the form of texts, films, photographs, drawings, or oral narratives, our purpose as architecture and cinema researchers is to collect these fragments of atmospheres in order to compile sensitive traces of one of the last mechanical camera factories in the world. The following pages present the first responses to our call.

#### NICOLAS TIXIER

**Nicolas Tixier is an architect and professor at the Ecole nationale supérieure d'architecture de Grenoble, AAU\_Cresson laboratory. He contributes to the ANR SCAENA. He is president of the Cinémathèque de Grenoble.**

*Nicolas Tixier est architecte et professeur à l'École Nationale Supérieure d'Architecture de Grenoble, laboratoire AAU\_Cresson. Il contribue à l'ANR SCAENA. Il est président de la Cinémathèque de Grenoble.*

## A Journey of Happy Coincidences

| Bruno Carrière

In May 1979, the *Office franco-québécois pour la jeunesse* sponsored the trip to France of a small group of emerging Quebec filmmakers made up of three girls and twelve boys, all in their early twenties. Hey yes, I agree, parity was shamefully lacking. As a remedy, we had elected Céline Tanguay as responsible and official spokesperson for the group.



**Bruno Carrière, cinéaste et directeur de la photographie, en tournage avec une Aaton 16 LTR à Deschambault, au Québec, été 1979 - Photo Bruno Carrière.**

The project was to go for a walk with Pierre-Yves Schaefer—our French fixer—and to meet many people from the community, distribution organizations, production cooperatives, small distribution companies. We also visited several film studios, as well as equipment manufacturers. It also gave us the opportunity to show our first

films to French distributors. The aim of the trip was to foster lasting exchanges and contacts between French and Quebec artisans on various aspects related to the establishment, viability, development and financing of traditional and independent cinema, whether fictional or documentary.

We arrived in Paris on Tuesday May 8th. From the first week, I remember that the encounters were indeed interesting, but nothing really memorable.

On Friday at noon, we had the weekend off. With two friends of the group—Michel La Veaux and Daniel Bisson—we jumped on the first train for Rouen for an appointment in the afternoon at the School of Fine Arts. We met with our friend Didier Funkiewiez—known to his friends as Funky—who had organized a small conference and screening for us with the graduates of the School.

The next day, Franky had scheduled a meeting with Jean-Pierre Rouette, a young director from Rouen who had just finished making a one-hour documentary entitled *Loulou et Marie*. We had a drink together; he told us about his film which he had produced on his own with a small crew of volunteers and an Aaton camera.

Then, we went to the Maison des associations for a screening. His film is a beautiful, serious and tender document on the life of the involuntary marginalized people of the old districts of Rouen who are mercilessly doomed to the digger and forgotten by the rest of the world. Rouette mentions that he will present his film at the Cannes Film Festival the following weekend. When I tell him that we will be in Grenoble in a ►

<sup>1</sup> Claire Lepage, Michel La Veaux, Rénauld Bellemare, Denis Boivin, Daniel Bisson, Gilles Cadieux, Édouard Faribault, René Lépine, Jacinthe Melançon, Guy Ouellette, Rénauld Racine, Céline Tanguay, Jean-Pierre Sabourin.

few days, he invites me to join him at the Festival, and says that he can accommodate me for a night or two. He adds that he will be in the company of the director René Vautier, his friend and mentor. I spontaneously accept Jean-Pierre's invitation and we shake hands on the promise of a weekend together on the Croisette.

The next day, the three of us spend our Sunday in Étretat with Funky and a small group of his friends, including one of the students I had met at the Ecole des Beaux-Arts and I had only eyes for. The sun is shining and the landscape is absolutely sublime.

Back in Paris, the highlight of the second part of the trip was for me the visit to the Kodak film production site in Vincennes; a totally fascinating work environment! At the time, the very modern factory supplied the whole of Europe with photographic and cinematographic film. Imagine a place where hundreds of employees work on several floors in the same conditions of

darkness as in a photographer's darkroom. The young director of photography that I was could finally understand in great detail all the stages of production of the 16 and 35 mm film that he used all year round without having the slightest idea of the manufacturing process. I vividly recall this visit which—although it almost entirely took place in the dark—opened my eyes wider still to my profession. Later on, I told the story of this visit to my assistant cameramen many times.

On the following Monday, we have an appointment with Jean-Pierre Beauviala at Aaton, but during the weekend I decide to meet up with Jean-Pierre Rouette and René Vautier in Cannes. I take the overcrowded night train and spend the entire trip standing or sitting on the floor between compartments. We meet the next morning at ten o'clock at one of the terraces of the Croisette. Huge relief, they are already there. We're happy to meet again, but I'm quite buzzed by my sleepless night on the train. In short, I'm too tired to think straight. Not a problem, the atmosphere is so invigorating that I feel energized by the effervescence of the festival. Not surprising, it's my first time there. I spend the week-end with them—and several other festival-goers I meet during these 48 hours—it was a memorable weekend.

Vautier impresses me and I feel privileged to spend two days with him. At the time, he is 52 years old. I hardly know him but I quickly learn a lot more about his reputation and his background. He's communist, a committed Breton filmmaker, and a relentless activist against French colonialism. Hero of the Résistance, he was awarded the Croix de Guerre at the age of sixteen. He graduated first of the production-direction section at the IDHEC (Institute for Advanced



Jean-Pierre Rouette and René Vautier, Cannes 1979  
- Photo Bruno Carrière.

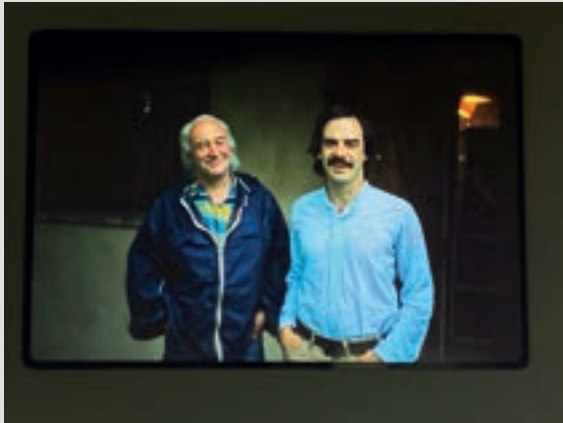

**René Vautier and Bruno Carrière, Cannes 1979 - Photo Bruno Carrière.**

Cinematographic Studies) in 1948. Over the years, he fought many battles with his camera. In 1972, he won the International Critics Prize in Cannes for his film *Avoir vingt ans dans les Aurès*. Vautier knows everything about the festival since he comes there every year; he helps me find my way around.

Curious to know what is happening in Quebec at this historically crucial period, he questions me; he wants to understand where I stand politically. I answer that I practice cinema both to make a living but also to bear witness to my convictions as an independentist; we are, at the time, one year—to the day—away from the referendum for independence that is to be held on May 20, 1980 and I am working on several films which campaign for the cause. That's when he gives me the same line almost all French people I've met since the beginning of the trip have served me: the General of Gaulle gave you a real boost with his "*Vive le Québec libre*." Didn't he? I gently answer that it was just a bump on the road that had made a lot of noise but that hadn't changed things on

paper, and that we didn't really need a great French visitor—as important as he may be—to move more quickly towards autonomy. I added that the discourse reflected a colonialist posture and that Quebec was no longer New France. I remember he was taken aback when I told him: "*You know René, it's been a long time since we were cousins.*" There was a silence... But, fortunately, we toasted again and the incident was over.

Since I had arrived at the Festival unexpectedly and without any preparation, I had no passes, let alone free tickets to attend screenings. So I spent my time walking around and trying to figure out how it all worked. I spent several hours at the Festival Film Market which is the largest of all the markets. I see countless film distributors and resellers of all kinds, essentially of lower category films. In short, the Temple peddlers—cinema version.

The big star of this 32<sup>nd</sup> Festival is undoubtedly Francis Ford Coppola who came to present *Apocalypse Now* in the official competition, whose production just quite cost him heavily. The film isn't finished; it is a working copy, without titles or credits. It is an unprecedented event, never before has the festival accepted an unfinished film in the official competition. Coppola is a cherished child of the festival and he can get anything he wants. Those who managed to see the movie came out stammering, in a state of shock. I won't be able to attend the screening, but on the other hand, I attend the press conference on Sunday morning. I can't remember how I did it, but I managed to slip up to the mezzanine. Coppola's performance is remarkable, he goes all in. He puts up a whole show because he is aware of two things: the festival leaders want him to get the Palme d'Or, and they're working behind the scenes to get the jury to ►

go in that direction. But he also knows that Françoise Sagan, who chairs the jury, is fiercely opposed to the idea of granting him the distinction because she campaigns for Volker Schlöndorff's film—*Le Tambour*—that she clearly prefers. In the end, neither will win entirely. To avoid a scandal, the 1979 Palme d'Or will be awarded ex-aequo to the two movies.

I spend the rest of the day with my friends Rouette and Vautier and in the evening, I take a night train back to Grenoble. I have a connection for Grenoble in Lyon in the middle of the night. With 45 minutes between the two trains. As I'm pacing through the waiting room of the Gare de Lyon, I see a man coming towards me with his bundle. The closer he gets, the more familiar he looks. Our eyes meet, and suddenly, what a surprise! It was François Protat! A director of photography from Montreal, originally French. We didn't know each other much at the time, but it was enough to throw ourselves into each other's arms. His trip was over and he was traveling back to Paris. We talked for a few minutes and parted ways to catch our trains. You do realize that the odds of such an encounter are really slim. My whole '79 trip was like that; full of anecdotes and incredible coincidences.

I arrive in Grenoble at dawn and return to my hotel. I get two hours of sleep before meeting up with the group to go to our meeting at Aaton.

Jean-Pierre Beauviala was already a highly respected figure at the time, and of international reputation, especially within documentary film circles. In Quebec, he had many friends within the community of Direct Cinema directors and directors of photography and he was very respected by the members of the technical department of the National Film Board of Canada.

We first go down the rue Bayard—a shopping street in the old city center—and take the little rue de la Paix with Aaton on both sides of the street and stop in front of number 2. We are facing the headquarters of the Company. The old building, with apartments above and shops at street level, is six stories high and rather insignificant. The storefront on the ground floor is painted blue with the words AATON in large black letters. No way to figure out it's a camera manufacturer unless you already know it. I admit that I am surprised by such discretion and simplicity. Given the reputation of the company, I expected a more remarkable storefront. We enter the porte cochère to access the inner courtyard. We find a door that seems to be the reception and we see Jean-Pierre waiting for us inside. I knew his face from flipping through several of the company's catalogs. It was moving to finally shake the hand of a true multidisciplinary image and sound genius. Jean-Pierre was a character from two eras - the renaissance and the future. You could feel it, you could see it, and you could hear it.



A group of young filmmakers visiting Aaton on May 21, 1979.



We followed him as we went through different doors from one room to another. You could see that the premises had previously had other functions and that the rooms had been reclaimed little by little, as the business evolved. At least that's the general impression I kept. The aesthetics and the harmony of the decor hadn't particularly been taken into consideration; occupational efficiency had been privileged.

Jean-Pierre received us with great generosity; he told us about his projects and introduced us to several people from his team of collaborators.

A happy coincidence struck again, more generous than ever. At the time, Jean-Pierre had already been working on the 35 mm version of the Aaton for a while. Jean-Luc Godard—who had come to live and produce video works in Grenoble for several years—was preparing a new feature film. He had asked Beauviala to create a mini 35 mm camera for him. A camera so compact and light that it would allow you to shoot incognito around the corner. On the day of



Jean-Pierre Beauviala, William Lubtchansky, and, on the left, Robert Leroux, rue Bayard, in Grenoble.

our visit, William Lubtchansky, Godard's director of photography, had come from Paris to see the first tests with this camera.

Beauviala invited us all to follow them and we went to the local cinema to watch the test reel on the big screen. Proud to participate in this small historic moment, we went down the street and into an old movie theater from another era. We sat randomly. The projector started and we saw Godard's head appear on the screen with a color chart in his hands. They had shot some shots in town and others in the countryside<sup>2</sup>. Some were stationary and others were in motion. Pans were unpleasant because of the strobe effect. We were explained that this was because of the shutter movement they had installed in the camera because their budget did not allow to do otherwise.

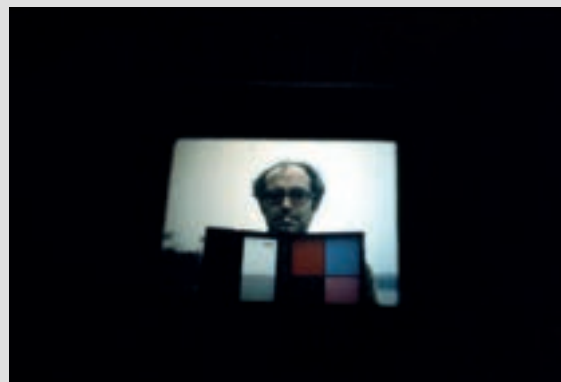

Screening of the first tests filmed with the 8-35 prototype in a cinema in Grenoble, May 21, 1979.

After the screening, we were able to exchange with Lubtchansky who was already at the time a very famous director of photography. For us, it was a unique opportunity to listen to a craftsman of this caliber. He was 42, and had already signed more than thirty feature ►

<sup>2</sup>

Some of these tests were filmed in Rolle, with Godard, and then in Paris where Caroline Champetier assisted Lubtchansky.

films. He was kind of a super camera star of his time. When he retired in 2013, Lubtchansky had 110 films on the clock.



**Left to Right: Robert Leroux, Jean-Pierre Beauviala, William Lubtchansky, Bruno Carrière.**

We returned to the offices with Beauviala because he wanted to show us two things before leaving. The first of the two was obviously the 35 mm camera that had been used to shoot the tests we had just seen. We lined up and followed him through a whole maze of storage rooms and offices to finally arrive in a workshop where the prototypist Robert Leroux was expecting us. With a *Gauloise maïs* in his mouth and white lab coat on his back, he shows us the second model of the 35 mm camera that he was assembling. It had a rough aspect and you could see large traces of planning on the surface. It was impressive to see that it all started there, with an aluminum specimen straight out of the foundry.

La deuxième chose que Jean-Pierre souhaitait nous The second thing Jean-Pierre wanted to show us was the anechoic chamber. He introduced us into a tiny, totally padded room where there was a 16 mm



**Jean-Pierre Beauviala handles a lens on an Aaton 16 LTR. Next to it, a Nagra is open and standing upright, and its engine is visible.**

Aaton camera and two Éclair cameras, an NPR and an ACL. One after the other, he operated them in the presence of an (at the time) extremely precise sound level meter. The Aaton won hands down in terms of decibels; the engine purred more quietly than a cat. It was his greatest pride I think—to have created the most silent camera of its time.

Beauviala created an extremely avant-garde technological universe (I also remember La Paluche), a circle of influence and a community of knowledge. His passion was contagious. It's like the etymology of his last name. Viala is above all the name of a small village in Aveyron: Viala-du-Tarn. Word of Occitan

origin, Viala designates a village or a small town. Which leads me to believe that Beauviala probably means “beautiful community.”

I never saw Jean-Pierre Beauviala again, but I followed his career thereafter and he never ceased to impress us with his inventions, each more efficient than the last. Some were commercial successes, others weren't. His company is still there, at the 2 rue de la Paix.

Before leaving for Montreal, I was able to see Martine again, the student from Rouen. At a time when the Internet was still a vision of the future, we agreed to exchange letters regularly and to call each other from time to time. We did so for nine months, a long gestation, and then we met again for good—and for life—after an encounter which turned out to be a happy coincidence.



Jean-Pierre Beauviala with the Aaton LTR on his shoulder.

#### BRUNO CARRIÈRE

**Bruno Carrière a étudié les arts plastiques. Il pratique la sculpture et la fonderie avant d'entamer, en 1971, une carrière de réalisateur et de directeur de la photographie mais aussi de producteur en créant les Films Cinétrie. Il a réalisé de nombreux films : un long-métrage de fiction, Lucien Brouillard (1983), des courts et moyens-métrages et des documentaires, téléfilms et séries dramatiques, pour la télévision, en France et au Canada. Depuis 1976, il est membre et investi, à différents titres, dans l'association des réalisateurs et réalisatrices québécois, l'ARRQ.**

*After his studies in the plastic arts, Bruno Carrière went on to work as a sculptor and a founder before embarking on a career as a director and cinematographer in 1971, and a producer by setting up the company Films Cinétrie. He has directed a number of films including the feature length Lucien Brouillard (1983), and short and medium-length films, as well as documentaries, TV films, and television drama series in France and Canada. Since 1976, he has been an active member holding various roles in ARRQ, Quebec's association of directors.*

## An Aatonian in Grenoble

| Valentina Miraglia

*“Don’t Miss the Action.”* On March 27, 2006, I am expected at the Aaton workshops in Grenoble. The action Jean-Pierre Beauviala is referring to in his invitation letter is a friendly visit from Raymond Depardon. Like Agnès Godard, Éric Gautier, Stéphane Fontaine and Cesare Charlone, Raymond Depardon is a fervent user of the Aaton 35. Having the opportunity to meet him on the same day as Jean-Pierre Beauviala is not to be missed.

At the time, I was finishing my Masters in Toulouse. My research then focused on the Aaton 35 III, a camera which, my intuition told me, materializes the evolution of a concept born from a prototype (the 8-35) wanted by Jean-Luc Godard to answer an alternative desire for directing and shooting.



**The first prototype of the Penelope 35 mm, open-hearted. At first, Jean-Pierre Beauviala dreamed of the possibility of adapting digital or film magazine - Photo Valentina Miraglia.**



**The 8-35 camera, engine side view, with its case. Photograph taken at the Conservatoire des techniques of the Cinémathèque Française, BNF - Photo Valentina Miraglia.**

The meeting and exchanges with Jean-Pierre Beauviala and his team marked a turning point in my research work. With the support of Laurent Mannoni of the Cinémathèque Française, I completed a doctoral thesis in 2012 in which I revisit the history of lightweight cinema by analyzing the aesthetic and practical repercussions of technical constraints on filmmaking. To open, delimit and deepen a field of reflection on the genesis of cameras, I approach the history of lightweight filming by defining a body of research on a century of cameras, from the chronophotographic gun of Etienne-Jules Marey up to the RED digital camera. It goes without saying that Aaton cameras are well positioned in the study.

On the afternoon of March 27, 2006, Julie Flament and her image crew were also at Aaton to test cameras for a future film. The manufacturer Pierre



Michoud answered all the filmmakers' questions. Raymond Depardon was there. With an Aaton35 III, he tested the 35MM 2Perf format intended for the Penelope camera. The test turned into an on foot shooting in Grenoble.



Camera on the shoulder, Raymond Depardon films, with an Aaton 35III, Jean-Pierre Beauviala in front of Aaton's mechanical workshop, rue de la Paix. The camera has been transformed into 2Perf, a format for the Penelope camera that was still being developed - Photo Valentina Miraglia.



Jean-Pierre Beauviala equipped with a Cantar sound recorder and Raymond Depardon filming, rue Bayard, in front of Aaton's electronics workshop - Photo Valentina Miraglia.



Jean-Pierre Beauviala welcomes Julie Flament and her image crew to Grenoble for the camera tests of his next film, of which Georges Merlan is the DOP - Photo Valentina Miraglia



A family portrait Director and producer Julie Flament, Jean-Pierre Beauviala, Pierre Michoud head of the Aaton's after-sales service, and filmmaker Raymond Depardon - Photo Valentina Miraglia.

Camera on the shoulder, Raymond Depardon followed Jean-Pierre Beauviala. With a Cantar sound recorder, the founding engineer of Aaton met up with Julie who was sitting at a café in the city center. My photo report documents these moments.

Le lendemain, je retrouve Jean-Pierre Beauviala dans ce même café pour un premier entretien, Cantar sur table !



Stroll in the city of Grenoble, wireless! - Photo Valentina Miraglia.



Jean-Pierre Beauviala and Raymond Depardon join Julie Flament, sitting at the café Le tonneau de Diogène, place Notre-Dame - Photo Valentina Miraglia.

### Interview with Jean-Pierre Beauviala, Grenoble, March 27-28, 2006

**V. M.:**

My work is to take a closer look at the Aaton 35 III. Let's begin with the fact that this camera was the result of your partnership with Jean-Luc Godard. Today it is a mark that makes this object a very unique and particular tool. Because one of the specificities of this "model" is that it is part of a history, of evolutions, of additional operations on a technical level. Hence the interest in this object

as an "object in the making." We could therefore say that the "historical circumstances of its birth" determined the history of its use today.

**J.-P. B.:**

Well, it's a bit complicated to answer, because, in reality, the Aaton 35 III has become what it is, over time, oddly, precisely by moving away from the recommendations Godard made at the beginning. The strange thing nowadays is that this camera has been returning to cinema lately because we've come back to the origins of its conception, that is to say to the design of a 16 mm camera, the Aaton XTR. The Aaton 35 III today has an instant magazine, time recording, lens positions in relation to the eye, the problem of silence. Everything in the Aaton 35 III makes it look like an Aaton 16 that shoots with 35 mm film. And that's what's strange: it's a comeback. Because when I designed the camera with Godard—in 1982-83—everyone was shooting with 16 mm, and he asked us something very different. So you could say that, paradoxically, the 35 III—as it is today—has returned to its origins: the structure, the functions, the silence, the marking of the 16 mm.

What Godard was asking for was exceptional. Yes! But people in the profession totally refused it. In other words, it was—exceptionally—a very small camera containing a minimum of moving objects. He almost wanted a Bell and Howell, a time-marking Bell and Howell. That's the story. And in a way he brought me to a dead end because, apart from him who wanted to make films all of a sudden, wherever he was ... (By the way, we were traveling in Spain two months ago with Julie in places where there were wind turbines, there was snow, there was wind, there were wonderful things and



To me, a city was a place to live. Not only a place of trade, not just a place of dormancy, but it is also a place of work. And unfortunately in cities today there is no more work. Work is gone, real work: transformation has disappeared

because we were more or less mentally scouting for her next movie—without really scouting—, we thought: “God! If we had a very small, light 35 mm camera, etc. ... we could make shootings that could be used in the movie.”)

But anyway, there it is. Those kinds of things never work out. Because afterwards, you need to connect the shots to the real film. So you might as well take pictures! In fact the idea of Godard was wrong. It was a wrong good idea. And nowadays it is much better to take pictures if you want to do that type of scouting because they do the same job. So why design a small spotting camera? It wasn't a good idea. And the point is, he never used it for that purpose, never. Anyway, Godard is a guy who wonderfully knows how to make cinematographers make images, but he doesn't know how to frame. He doesn't even know how to use a lighter, he's very myopic, he can't see a thing. So he doesn't know how to use a camera! So we shouldn't have done this. And so little by little the camera 35 caught up with the Aaton 16 and we are in the process, with the Penelope, today, finally, of making an Aaton 16. Except we put 35 mm film in it. That's it.

So saying it was in progress... I wouldn't say it was in progress, I'd rather say it was searching for its origins, with the big sister, the XTR 16 mm camera. It's completely the opposite, the Aaton 16, because it was a camera I was making for myself, according to specifications defined by my own needs, the needs of the film I wanted to make. And everything at Aaton is linked to this first film which was never made. It was about shooting on the street, to show the city, etc., and the only thing that came out of

this “unshot” film is: THE CAMERA ... and Aaton. “But Aaton on the street where everyone on the street—as we showed you yesterday with Raymond [Depardon]—can see what is happening inside a company, a factory, workshops, can see people at work. It was

one of my concerns.

My main concern wasn't to make films of my night fantasies like Fellini or Julie Flament. My preoccupation was to theorize on *What is a city?* To me, a city was a place to live. Not only a place of trade, not just a place of dormancy, but it is also a place of work. And unfortunately in cities today there is no more work. Work is gone, real work: transformation has disappeared, the secondary sector as it is called in economics; the primary sector is mining, agriculture ..., the secondary is transformation and the tertiary is trade. And in the city there is practically no secondary left. Before there were carpenters, coachbuilders, painters...

**V. M.:**

Indeed, today society no longer makes a living that way!

**J.-P. B.:**

Precisely! But at the time it did, in Grenoble there were upholsterers, carpenters. Aaton was a carpentry. And today everything has disappeared Like in Belleville, in Paris. In Belleville, they were only craftsmen, everything you could find in Paris was made in Belleville. So I did with Aaton what I didn't show by making the film, since the film was never made. ▶

**V. M.:**

In other words, you provided an opportunity for filming this. People say that the Aaton 35 promotes “new” modalities of narration, that its use is sensitive to the perception of reality. Watching films shot with Aaton made me realize that the Aaton workshops marked the history of this technique. To the point that the Aaton 35 III challenged the previous, bulky and imposing filming methods.

**J.-P. B.:**

Absolutely yes!

**V. M.:**

The movies shot by Cesar Charlone, *La Cité de Dieu*, by Claire Denis, *Beau Travail*, by Walter Salles, *The Motorcycle Diaries* ... are all movies where the device becomes an integral part of the directing, along with the actors, the assistants, the landscape. Their cinematic language converges towards the use of the shoulder camera to recover a documentary style. In an interview with François Reumont, Eric Gautier said that for the film *The Motorcycle Diaries*, Walter Salles “wanted to rediscover a documentary style, while building fiction and the evolution of characters and situations.” On the basis of specific characteristics of the object, my analysis describes the high impact of the camera on certain shooting conditions, and the new relationships that are established around the object between the director, the actors and the technicians.

We could say that the Aaton 35 camera had formalized a particular language, and that today this language is readable either by the type of shooting practices that presuppose its presence, or by the aesthetic choices of the image.

**J.-P. B.:**

The question is quite important. But before coming back to this subject, to the relationship between the “filmer” and the filmed, and to the instrument that is or isn’t between the two. Are there any other questions in your survey? Because I’d rather wait before coming back to this fundamental question, and I’d like to give myself time for a coffee.

**Georges Méran (Chief op.):**

In fact, that’s what I was saying to Julien, my assistant. The camera, I can feel it, it’s like a part of me now. I see how it sees, or the camera sees how I see, I don’t know, and it’s pretty amazing to feel a camera to that point. I shot with many other 35 mm cameras but I’d never had that feeling of intimacy. And that’s important to me.

**V. M.:**

With this camera the human dimension—like the breathing of the operator—enters the shot. On this subject, Jacques Audiard said—again in *LUMIERES, les cahiers n° 1 de l’AFC*—that he likes the shoulder camera and particularly Aaton “Because I can feel the breathing of the operator, because I can smell the human inside. It’s not motion-control.” And even if the shot is still, shoulder shooting gives breathing to the shot.

**G. M.:**

If you want to make still shots to the eye, when you look at someone, you can stare: it’s a still shot. And movement with this camera is as simple as that: if you want to move, you move with it.

**J.-P. B.:**

There are two concepts here. There is indeed the idea of the cameraman’s intimacy with his object when it is well balanced, close to him, purring—and it’s the



story of the “cat on the shoulder,” which feels even more extraordinarily real with the Aaton XTR which has even more the shape of a shoulder. Unfortunately, we haven’t been able to transpose this same very close to the shoulder shape to the Aaton 35 because, by structure, the loop of the camera 35 prevents us from doing so. But it works out quite well: see how Georges feels the same intimacy. That’s one thing. But the other thing about the camera on the shoulder, apart from all considerations,—which we will discuss later—is that even when you make a still shot (at the shoulder) it moves all the time. There is indeed the breathing, the micro movement that makes you feel inside the picture (here, the projected image), you feel that there is a human who leads it: it’s not a crane, it’s not a machine and that is why I am a very fond of—when it is possible—the camera on the shoulder. It’s difficult to work with a camera on your shoulder because if you move too much, you get dizzy and you feel sick. But when you can make a still shot that’s not quite still, it’s great. Because you can feel that it’s actually a person’s point of view. It’s not the point of view of a Sirius or whatever! ... We put life not only because we use film with its grain that dances and that goes to get information on people’s heads, but also because we feel that it is a man, a woman who chose the point of view: what you’re referring to, probably, when you say, “the little vibration.”

**V. M.:**

So we could speak of a “medium use profile.” With the 35III camera, the “shoulder shoot” would be the most consistent as regards the original manufacturing project, the why it was designed. It is particularly appreciated in this shoulder configuration, which makes its specificity. On a tripod, it loses its *raison d’être*.

**J.-P. B.:**

Oh yes, well. A camera on a tripod loses four fifths of its *raison d’être*. You might as well take an ARRI or anything else. But hey, wait, there is a difference, and even two differences. The first one is that the Aaton, by its design—because precisely we did not try to make it hyper silent—is the only 35 mm camera that exists these days where the lens is directly related to the film, to what is called the channel plate. So there is no movement between the lens and the film. That’s why it’s still the camera that makes the most crisp films. The incredible thing is that the most expensive films that are made on tripod by Panavision, Moviemcam, Arriflex,—Arriflex is not too bad, there aren’t too many vibrations—so the incredible thing is that on a Panavision people buy priceless lenses, accessories, and all kinds of stuff ... and the images are blurry, always! You can recognize the Panavision and Moviemcam images: they are the worst, blurry. Why? Because, precisely, to build silent cameras, instead of designing intrinsically silent movements like we did, they make noisy movements and then try to isolate the noise so that it doesn’t come out of the camera. To isolate mechanical noise you need to put rubbers, including on the channel plate, which means the channel plate spends its whole time vibrating too—as micro-mechanically as possible—but it vibrates when you make a picture. Which means that you can have lenses with thousandths of millimeters and microns of definition, the film moves, so the films are blurry. That’s one of the first justifications for, after all, using a tripod with an Aaton. Godard had made comparisons between the Arri I don’t know what and the first Aaton, and the guys couldn’t believe it: it was the same lenses, the same films, the same filters, side by side—it was Renato Berta who said that—and in the Aaton there was a certain something that what finer, sharper. That’s for the first point. ▶

Secondly, using a tripod with an Aaton—although the camera is not made for that—indeed presents the advantage that when you finish a magazine, two seconds later, you can put a second one, and the scene doesn't stop. That's the second advantage. But the genius of the camera is less obvious on tripod. To the extent—incidentally this is what you see—go to ARRIFLEX in Munich and you'll see, all the cameras on display are on tripods. If you come to Aaton the tripods are all old as Methuselah: you wouldn't even want them. In the same way that there is no lens hood, there is no tripod.

**V. M.:**

I think there is a connection between the cinema of the 80s (I'm naturally thinking of Jean-Luc Godard) and the French and foreign cinema of several contemporary filmmakers such as Jacques Audiard, Claire Denis, Patrice Chéreau, Gonzales Inarritù. It seems to me that the presence of the Aaton implies a particular collaboration between the director and the chief operator: a search for dynamics rather than stability during shooting.

**J.-P. B.:**

All the people you quote, in fact, are documentary filmmakers. Godard always said that he was a documentary filmmaker, that his calling to cinema was Jean Rouch and that he became a filmmaker the day he saw Rouch's films. Basically, Walter Salles, Raymond Depardon, Claire Denis, all these people, their way of filming, their way of being, the subjects they choose can be justified by the fact that they fundamentally are documentary filmmakers. Because I also was a documentary filmmaker, but I didn't know all these people at the time. I was on my own in Grenoble, I was a university engineer and professor with a desire for films, that's all. And I build myself a

camera because my film, which was a pamphlet, was first and foremost a documentary. I used the walk in the city to present a theory: "Here's how cities should be made." And so the Aaton camera was built in a documentary perspective (mine), and it ended up being used and changing the heavy cinema, because it was a camera that offered a very high quality of image etc., etc. We could add that modern cinema—at least in part: a quarter, perhaps a third, it's not huge—has become very documentary.

**V. M.:**

Could we say (still speaking about cinema) that the use of the camera on the shoulder and the kind of sequence shots that characterize it have spread to the extent that it has become the signature of an Aaton shooting "style," even in other countries? For example, I'm thinking of Michael Mann's *The Insider*, and despite the fact that it wasn't shot with an Aaton—the first sequence (the interview granted to the character played by Al Pacino) seems to me, for various reasons, to carry the possibility of an Aaton presence.

**J.-P. B.:**

It's hard for me to answer because I haven't seen the film. But I'm not surprised that great directors, from a certain point onwards, try to reproduce what the directors you mentioned earlier have done.

**V. M.:**

A remark comes to mind. The Aaton 35 III is the culmination of a concept that originated with a prototype (8-35) that was implemented in order to respond to an alternative desire for directing and thus filming. But while this prototype was being built, the cinema had already changed (had taken to the streets, had

offered alternatives to the installed cinema, had accomplished its “new wave” ...). Today, the Aaton 35III marks the evolution of this search for lightness, compactness, dynamism and, while cinema has become incredibly diversified, it offers a tool that allows directors and operators to design their shooting more freely. It is quite a historical twist that a concept intended to meet a demand of the 70s and the 80s for an advanced camera represents an alternative for today’s filmmakers.

**J.-P. B.:**

We’re heading back to the beginning. Aaton went for 35 mm at the request of Godard. That was 1979-1980, and it had been about ten years since I started to publicize the Aaton 16 mm camera. Jean-Luc came with his request for a very small camera you could put in a door pocket, to be able at any time to film something that he could possibly incorporate in a film later on.

So he asks us to make a very small camera, really very small, and we design outside Aaton’s conventions because, on the one hand, it was a 35 mm, and at the time I didn’t like that format because it represented heavy, comfortable cinema, etc. ... And besides, he made us make an object that wasn’t very usable in my idea of cinema. In other words it was rather a notebook, and I’d nearly say he would have been better off with a camera: a Leica permanently with him, it would have given the same result. Anyway, we made this camera that turned out not to be usable at all to the chief operators who worked with him. That is to say, he was making a camera for himself—which he never used, practically—and all the people who wanted to use it around him thought that the magazines were too small, that the viewfinder was not bright enough, not precise enough, not enough of all sorts of things. So we spent years transforming the

prototype, trying to make it usable by people in the profession and in fact, we now realize it when we look back, we spent too many years in the end wanting to do in 35 mm what I had already done ten years before in Super16. That is to say an object—to really speak of what the Aaton camera is and why the Aaton 16 has transformed the relationship of filmmakers, chief operators, cameramen, documentary filmmakers with the object of their profession—... a camera that was based on three things, three principles.

Firstly, the highest possible image quality, given that, for me, shooting in 16 mm didn’t mean we couldn’t broadcast in movie theaters or we had to make a camera for television. You must remember that 16 mm was mainly for television. So the first constructive idea of the Aaton was to make an image as sharp as possible.

Secondly, to have a camera—but we didn’t invent that—with an instant magazine, so that, we will talk about it later, when you need to change the film, to reload the camera, you don’t cut the relationship that has been created between the person who is filming and the people who are being filmed.

Thirdly, what is fundamental and that is the very characteristic of the Aaton is that it is a camera that—at the shoulder—lies at the very back of the shoulder of the framer (it is the first one of its kind). That’s when I used the “cat on the shoulder” image. It was the first camera that really became one—deeply—with the cameraman and didn’t get in the way between him and the people he was filming. At the time, Georges Merlan reminded me earlier—we used to say that the nodal point, i.e. the point of rotation of the images when you move was in the same plane—almost—as the cameraman’s



**In fact, the Penelope, which is the completion of the Aaton 35III, is an absolute return to the Aaton basics. Or in other words: the best possible image, silence—silence is very important—the camera towards the back and of course the instant magazine.**

eye. Which explains the bizarre shape of the viewfinder that allows you to have the eye at the same level as the lens, as the nodal point of the lens. That's why, today, the Aaton 35III, after many avatars, modifications to achieve the Penelope (the same camera, simply with slightly more modern materials, with electronics replacing the mechanics) returns to the original Aaton conception design. In fact, the Penelope, which is the completion of the Aaton 35III, is an absolute return to the Aaton basics. Or in other words: the best possible image, silence—silence is very important—the camera towards the back and of course the instant magazine. Because the instant magazine has two advantages. The main advantage in our cinema is to be able, when changing magazines, not to wait too long. You almost have to do it in the same breath that exists between the person filming and the person who is being filmed. The magic of the relationship that is created between the cameraman and the object (or subject) filmed must not be broken. As I said earlier, in the end, the Aaton 16 and consequently the Aaton 35—as it has become—is a documentary camera, documentary-minded. Which means that you need a lot of freedom of movement and, as you were telling me about dancing, you need to be able at all times, because you have a camera on your shoulder, to have a point of view that is not imposed by an a priori on framing but by something you invent along the way with the filmed object. What you said earlier about dancing that calls for the movement of the camera is totally true. You can totally imagine that an actor—he knows that—if he feels that he has, in front of him, someone who is mobile and able to follow his moves, is going at times to invent stagings. I saw that with a girl called ..., I can't remember her name, who knew how

to stand in front of the camera and who invented things, as an actress, who didn't wait for the director to tell her what to do. She felt that the camera was there: she turned her head, she got into the light, she made a gesture—as you said earlier about the gesture of the arm—and the cameraman could

follow her. You can't do that with a tripod: you stay on your marks and you try to say your text, to act smart, and you lose the elegance of the gesture, we could say.

So, indeed, from the beginning, in the Aaton 35 and 16 cameras, we had put time marking, the famous system that allows to synchronize sound and image, as we saw yesterday, without any connection, and which allows, especially when you stop and restart, not to have to do a clap. Yet another way to avoid breaking the magical relationship between the cameraman and the person playing. Because even in a documentary, most people—unless they're completely idiotic—stage themselves. It's always in relation to the camera. And it's like what you said earlier about the Rouch ciné-trance, the creation between the cameraman and the person of a kind of..

**V. M.:**  
... empathy...

**J.-P. B.:**  
Yes, that's it, that's exactly it: where everyone stages: I push you, you shoot me, etcetera. And indeed, it is true that the Godard camera as it was at the beginning slightly led us in the wrong direction essentially because Jean-Luc had told me: "I don't care about the sound because anyway, I'll do it the

Italian way, with post-synchronization.” But that was crap, it was the opposite of what I had always done since the beginning of the Aaton cameras, that is to say the quietest camera possible—even today the Aaton super16 cameras are the quietest that ever existed. And all of a sudden, we made a 35 mm camera that made noise and that ruined the career of the 33 mm camera, because in the meantime cinema had taken a documentarist twist with much less post-synchronization, much less. We like it now, especially with the improvement of recorders, microphones etc..., directors, sound engineers ... love to post-produce with real sounds. And unfortunately, the camera was noisy, we did everything we could to make it silent, but by structure it wasn't built to be silent.

And to speak of the 35III, as the microphones become more sensitive, as people because of the use of the wide angle are forced to put the pole further, as the actors no longer carry their voice but mumble, Aaton 35 III camera still makes too much noise for the new way of recording sound. Even in three perfos, which makes much less noise than four perfos, the unfortunate is still too noisy. So we decided two years ago to make a silent evolution, and that's Penelope. We call it Penelope like that but we could have called it 35IIIA or 35IV. But hey, it's prettier to give her a name like that, of this famous woman who worked at night to undo what she did during the day. Which is a bit like the way we work at Aaton: always question, always undo and redo.

#### VALENTINE MIRAGLIA

**In 2010, Valentina Miraglia – filmmaker and cinephile – and Laurent Mannoni worked together to produce a photographic inventory of lightweight cameras for the Cinémathèque Française. She continued this work in a doctoral thesis that was defended in 2012 and whose jury included François Albera (chairperson) and Jean-Pierre Beauviala (founder of the Aaton company). Today, Valentina Miraglia is a visual artist who lives and works in Paris and whose artistic activity has an international resonance. The Miramorphoses are an example of her work that lies between the analysis of individual memory and the study of how this memory becomes a collective imaginary.**

*Cinéaste et cinéphile, Valentine Miraglia réalise en 2010 pour la Cinémathèque Française auprès de Laurent Mannoni un inventaire photographique des caméras légères. Elle approfondit ce travail dans une thèse de doctorat soutenue en 2012. François Albera en préside le jury auquel participe également Jean-Pierre Beauviala, fondateur d'Aaton. Aujourd'hui artiste plasticienne, Valentina Mir vit et travaille à Paris. Son activité artistique bénéficie d'une aura internationale. Ses œuvres, les Miramorphoses, se situent entre l'analyse de la mémoire individuelle et l'étude de la façon dont cette mémoire devient imaginaire collectif.*

## Not to film but to sing with a camera

Éric Hurtado

Godard

I was the first one to put the camera on my shoulder, today it horrifies me to see all those TV morons who put their cameras on their shoulder. The consequence is that we don't know how to frame anymore, because you can't frame from the shoulder.

Beauviala

There, I agree: you frame from the hand. No one ever looked at anything with a shoulder.

Jean-Luc Godard

You frame from the hand, from the stomach, from the eye, but from the shoulder there is no frame. 3/4 of the professional operators look with their shoulders and their feet. What we need, and that's why I need a mounting, is for the camera to land more like a bird<sup>1</sup>.

Yes, a bird. Jean-Pierre Beauviala going through Mens perched on his bike, mechanical perfection! (In tune with the unfolding of the world, like steel blades on the cylinder of a music box). Freedom and rigor, the harmonic of a life.

He often answered before I finished my questions. He illuminated them from his point of view, opening a window on an ever-new landscape, that of his country house, turned towards the sky, beyond the walls. Both minimal and generous, he had conceived it like his cameras, a refined architecture, just the right balance between sky and earth, to bring in the rumors of the seasons.

I came to live in Mens with Shiraz, my wife, almost fourteen years ago. Four good, poetic, reasons for that: The troubadours, it is a territory of langue d'oc and of the countess of Die, the *trobairitz*, singer of love, joy and youth, still dazzles the sunny boxwoods. Jean Giono who made of the Trièves a "cloister of mountains," the Mont-Aiguille, figure of Dante's Purgatory, axis of the world for the hermetists and kingdom of Messire Gaster in the *Quart Livre* of Rabelais and Jean-Pierre, like an echo that I knew was here, without knowing where.

Grenoble, rue de la Paix. As a student at Sciences Po (not for long because I was probably too rebellious), it's winter. I jump over the puddles of melted snow to go and have a mint tea on the other side of the square and put the world to rights with my friends, under the calligraphy of a verse of Rumi. I like to walk through this street that looks like a huge aquarium, laborious and mysterious. Aaton, it's nighttime, an alchemical green light bathes the large windows of the workshops, I think of Father Ubu's candle.

In the fall of 1975, my uncle Guy and his friend Vincent made short fiction films in 16 mm Ektachrome. I was still in high school and I remember a story about a dark cellar and oranges falling down the stairs one by one to end up at the foot of a mysterious assassin... They had once met Godard at la Villeneuve, who according to them was not very talkative, but their master was Brian de Palma and his *Phantom of Paradise*. Café Stendhal, in the fumes of the percolators and the revolution (we are all red and black) we drink hot chocolate. They take a Pathé Webo out of the bag and run it empty. Beautiful and noisy! Aaton is just a stone's throw away but the brand new Aaton 7 is too expensive, they already evoke it as an unattainable legend. I

1

Jean-Pierre Beauviala and Jean-Luc Godard  
« Genèse d'une caméra », *Cahiers du cinéma*, n°350,  
août 1983, p. 50.

think of the desired camera and look through the fogged-up window at a pretty girl walking in the rain.

Spring 2006, we are preparing our movie with my brother Marc. Jean-Pierre welcomes me at Aaton's to introduce me to the A-Minima we insist on shooting *Jajouka, quelque chose de bon vient vers toi* in Morocco with, even though it is not generally



**Simon Blanchard, assistant operator, loads the Aaton A-minima. Shooting of *Jajouka, quelque chose de bon vient vers toi*, by Marc and Éric Hurtado - Photo E. Hurtado**

used as a first camera. I operate it. A slight rustle of moths at night. It feels good to handle, I don't put it on my shoulder. I try an XTR, even quieter, but can't stand it, I feel like I'm turning into a tripod. I want a camera that I can hold like my Leica, as an extension of the eye, with all the mobility of the head and not just that of the torso.

In the A-Minima, the film adopts the profile of a wave in the channel plate before coming to rest against the window, resulting in exceptional image stability. A wave for a lake. You were always quick to talk about your findings, such as how to take advantage of the curvature of the film generated by the loop so that you could almost do without a presser. The technical solution is also knowing how to make a clearing to reveal the potential of the matter. You often spoke of the "animality" of a form, yes because it is endowed with a soul. (Didn't Cézanne quoting Saint Thomas Aquinas say "the soul is the form of the body"?)

We are now surrounded by a panoramic landscape, a fresco of the 19<sup>th</sup> century representing the Trièves. A true romantic diorama where adorable putti throw flowers on us from the ceiling, in an eternal spring. We're at the Café des Arts in Mens. Giono was there too before the war, at the time of the *True Riches*. Suddenly, an image appears in a mirror; you, smiling Ulysses, behind the beautiful Penelope resting on a walnut table.

Someone knocks, you walk in and wish they hadn't cut down the trees on my street under construction. They're going to plant new ones soon, but it doesn't matter, you're furious. You visit my house, there is a garden facing south and the dry mountains of the Dévoluy, a vine of a rare grape ▶

variety, the Baco noir (this say this wine can drive you crazy!) waiting for the sun to offer us shade, and lots of air for the shouts of the children.

You dropped by to see the movie *Jajouka* which, after several screenings at the MoMA in New York, has just been added to the museum's collections. You really enjoyed the night scenes filmed by torchlight, at the full aperture of the Zeiss. We had shot during a whole night with Pascal Auffray, the brave chief op, in the cave of Bou Jeloud, made very slippery by the burning olive oil dripping from the torches, (the kind of things you don't think about ... we had to hold on!) It was one of the last films shot in Super 16 mm, we had to fight for that, for what we felt was an obvious love affair, so much in line with the film's; the gold of the sun on the silver salts of the film.

*"From now on, alongside his traditional flute, the god Pan also carries an Aaton A-Minima on his shoulder."*  
(Nicole Brenez).

A small digital Canon falls into your hands, you think that a Super-16 format sensor is more than enough to make good pictures. More is too much. Small and mobile, always, like your new camera project Libellule. You want to stay, you want to linger. We drink apple juice silently until the light goes down.

October 2016, Jean-Pierre sends me: *"a little iPhone movie thought out and made out of the blue (I was almost put out of business)"*. A harvester in the field in front of his house in Montvallon. It is mowing wheat in the summer light and moves forward until it comes to maneuver very close to Jean-Pierre, very close indeed, and then moves off again.



**Filming the machine. Videograms from a movie shot on an I-phone by Jean-Pierre Beauviala, Mens, 2016 - Jean-Pierre Beauviala**

### **Gold dust.**

I remember ... Grenoble, I was young. A backlight of soft and cold gold on the Vercors. Everything seems to be lost and given in a kiss, just before dark. I'm sure Jean-Pierre and Jean-Luc saw it too, forgetting everything but the joy of the next day.



## ÉRIC HURTADO

In 1980, brothers **Éric and Marc Hurtado** founded the group **Étant Donnés**, which quickly gained international recognition with shows in Europe and the United States and through collaborations with major artists on the avant-garde music scene. In 2012, they co-directed the film **Jajouka, quelque chose de bon vient vers toi**; it was shot in Morocco and released at several international festivals, the Paris-based Cinémathèque Française and Musée du quai Branly Jacques Chirac, and the Museum of Modern Art in New York that included it in its collections.

Since 2005, **Éric Hurtado** has devoted his time to photographic works that poetically question landscape and reality, as well as the medium itself in its phenomenality, guiding the viewer's gaze to the limits of the visible and the invisible. The numerous solo and group exhibitions of his work include **Dreamtime** at the art museum Les Abattoirs in Toulouse, and a retrospective at Gallery AMU in Prague.

*En 1980, les frères Éric et Marc Hurtado fondent le groupe Étant Donnés qui obtient rapidement une reconnaissance internationale avec de nombreux spectacles en Europe et aux États-Unis et des collaborations avec des artistes majeurs de l'avant-garde musicale. En 2012, ils réalisent le film Jajouka, quelque chose de bon vient vers toi, tourné au Maroc, qui sortira dans plusieurs festivals internationaux, à la Cinémathèque Française, au Musée du quai Branly à Paris puis au Museum of Modern Art à New York, qui l'intègre dans ses collections.*

*Depuis 2005, Éric Hurtado se consacre à un travail photographique qui interroge poétiquement le paysage et le réel, mais également le médium lui-même dans sa phénoménalité, entraînant la vision du spectateur aux limites du visible et de l'invisible. Nombreuses expositions personnelles et collectives dont Dreamtime au Musée des Abattoirs à Toulouse et une rétrospective à la galerie AMU à Prague.*

## The Mechanical Curvature of the Film

Around the intelligence of a piece, meeting with Pierre Michoud and Eric Hurtado, café La Table ronde, Grenoble, September 28, 2020.

Vincent Sorrel

I'm not sure if the optical center is in the middle of the window.  
Here is the sky, if you are inside or outside the focal plane, it doesn't matter, it's all blue, it's all focused. What is the image? Jean-Pierre was thinking about what the image is: the sky will always be up there and it will always be focused because it is at infinity.

Pierre Michoud

Camera manufacturers have used the mechanical qualities of film—in particular its strength and flexibility—to design coaxial magazines which, from Debie Parvo to Aaton cameras, have made it possible to reduce the size of the cameras by using the twisting capabilities of film<sup>1</sup>. To make a smaller camera, with a 60-meter magazine instead of 120 meters, the design of the A-minima is based on a “lack” of plasticity: the film takes the shape of the reel when it is stored. Once unrolled, the film remains arched. To mitigate this phenomenon, film manufacturers have introduced an anti-curl *layer* into the substrate composition. However, the film still retains a slight curvature which is due to a difference in tension between the substrate and the emulsion.

The design of the A-minima uses this curve to imagine its mechanism in relation to that of the film. On most

<sup>1</sup> Feed and receive coils are on the same axis, which saves space.

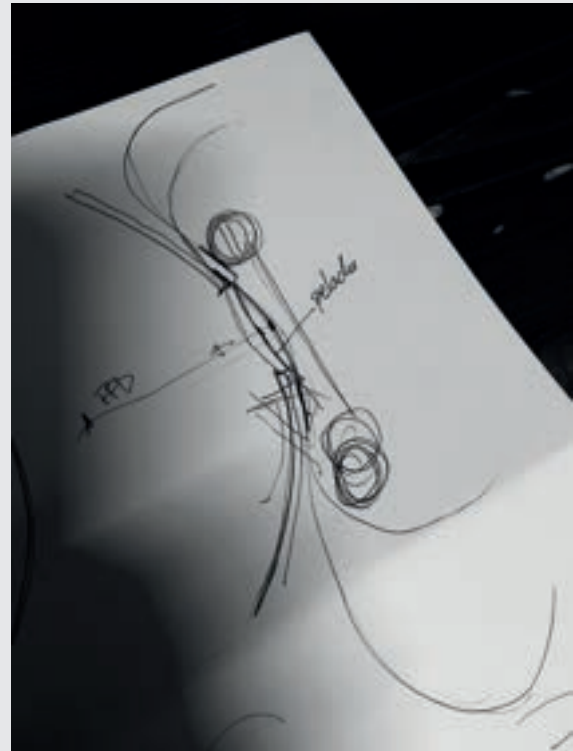

L'œil de l'A-minima formé par la rencontre de la pellicule avec la plaque canal à l'endroit de la fenêtre. Dessin de Pierre Michoud - Photo E. Hurtado.

trad légende ?

cameras, the gate is usually straight, flat and smooth. However, on the A-Minima, it is curved and its curve is reversed in comparison to the film. In general, several aspects are reversed compared to other Aatons. The film is conditioned for the A-minima with the emulsion side on the external side (winding B): the mechanical design of the camera relies on the phenomenon of *curling* to constrain the film so that it presses itself against the gate. “In internal emulsion winding, the emulsion tends to want to move away. In external emulsion, it is the opposite [...]. Finally, the claw is also reversed compared to the other Aaton cameras: it catches the film on the magazine side. Doing so,

it helps to press the film against the gate, which measures a little less than 16 mm, in order to constrain it and arc it across its width.

This design allows to do without the presser: a fixed part—a clasp—contains the film but does not hold it: the film itself exerts the pressure, guided by lateral pressers that press on the edges of the film. Not only is the film curved in its length, but also in its width,” said Pierre Michoud, Aaton’s service manager and now head of sales for Aaton Digital. The window is not only curved but also cantilevered relatively to the gate: thanks to the softness of the surface treatment, this texture, which frames the window like a 19th-century painting, does not scratch the film and, as Pierre Michoud points out, makes it possible to “stiffen the film” at the moment of exposure. At the



Gate, 16 mm A-minima camera - Photo E. Hurtado.

critical moment and at the sensitive place where the light impresses the film, the film is stiffened, curved, vertically and horizontally. Pierre Michoud, who for a long time was in charge of camera adjustments, points out that to measure the flange focal distance



Gate, 16 mm A-minima camera - Photo E. Hurtado.

on an A-minima, a special tool is needed, which is also curved, because the flange focal length—identical everywhere on another camera—is not exactly the same at the top, the bottom and in the middle of the image that is formed in an A-minima.

## Aaton at Work: Photographic Tracks

Caroline Champetier  
Pascal Lagriffoul  
Alain Sarlat



Aaton Photokina stand, Cologne 1974

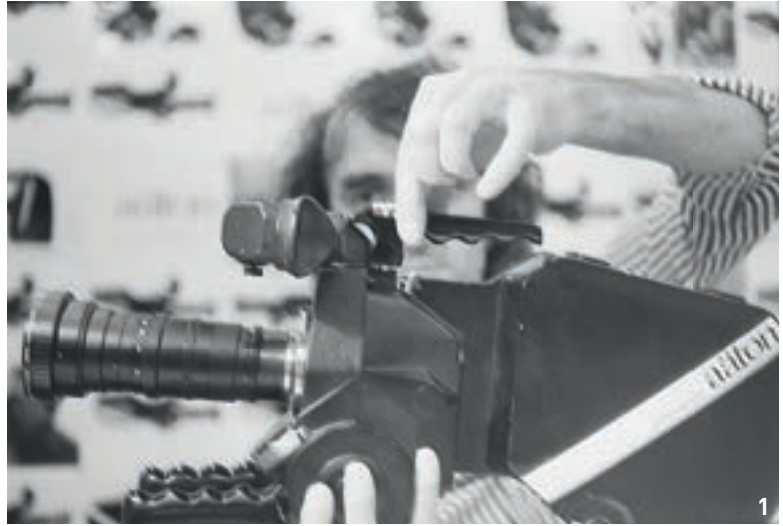

1 : Aaton 7 held by Jean-Pierre Beauviala

2 : Director of English Television, Photokina Stand, Cologne 1974

3 : Jean-Pierre Beauviala and an English TV director with the Aaton 7 camera, Stand Cologne 1974

4 : Jean-Pierre Beauviala and a Danish Television director





The Aaton mechanical workshops, behind the glass of the rue de la Paix in Grenoble (ca. 1980)

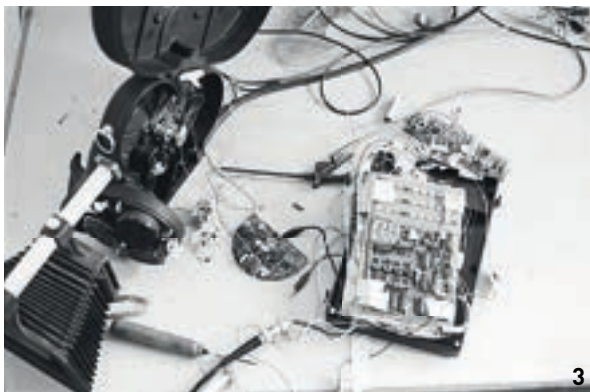

- 1 : Quartz tests with a Nagra 4 and a Zoom (1972)
- 2 : The famous quartz cases for time marking
- 3 : Electronic do-it-yourself with an Arri for time marking
- 4 : Prototype LTR camera
- 5 : Prototype LTR camera



1 to 4 : Jean-Pierre Beauviala, electronics workshop, rue Carnot, Grenoble





1 : Jean-Luc Godard and Francis Reusser with the prototype of the camera 8.35 (ca. 1978)



2 : Francis Reusser, Jean-Luc Godard, Robert Leroux and Jacques Lecoœur around the 8.35 camera prototype (ca. 1979)



3 : Jean-Luc Godard testing the viewfinder of the 8.35 camera (ca. 1979)



4 : Jean-Luc Godard with the LTR camera (ca. 1979)



1 : François Weulersse and Jean-Pierre Beauviala studying the regularity of time marking  
2 : Julien Beauviala on the board of the Aaton design office with Jean-Pierre Beauviala (1973)



- 1 : Michel Brault (ca. 1985)
- 2 : Louis Malle and Etienne Becker (ca. 1977 )
- 3 : Jean Rouch
- 4 : Jean-Luc Godard testing camera balance 8.35 (ca. 1979)





1 : Louis Malle Jean-Claude Laureux, rue Carnot, Grenoble (ca. 1977)

2 : Jean Rouch and Jean-Pierre Beauviola discussing sound (ca. 1977)

3 : Jean Rouch and Jean-Pierre Beauviola discussing in front of the LTR camera diagrams (ca. 1977)



1



2



3



4



5



6

- 1 : Michel Brault and his assistant (ca. 1985)  
 2 : Louis Malle and Jean-Claude Laureux, rue Carnot, Grenoble (ca. 1977)  
 3 : Jean-Pierre Beauviala and Jean Rouch with the Aaton 7 camera  
 4 : Etienne Becker Louis Malle Jean-Pierre Beauviala Jean Claude Laureux, rue Carnot, Grenoble (ca. 1977)  
 5 : Jean-Pierre Beauviala and Jean Rouch with the battery on the head  
 6 : Louis Malle and Jean Claude Laureux, rue Carnot, Grenoble (ca. 1977)  
 7 : Louis Malle, François Weulersse, Jean Claude Laureux, Etienne Becker, Offices in rue Carnot, Grenoble



7



1 : Jean-Pierre Beauviala

2 : Jean-Pierre Beauviala and the Aaton 7 camera





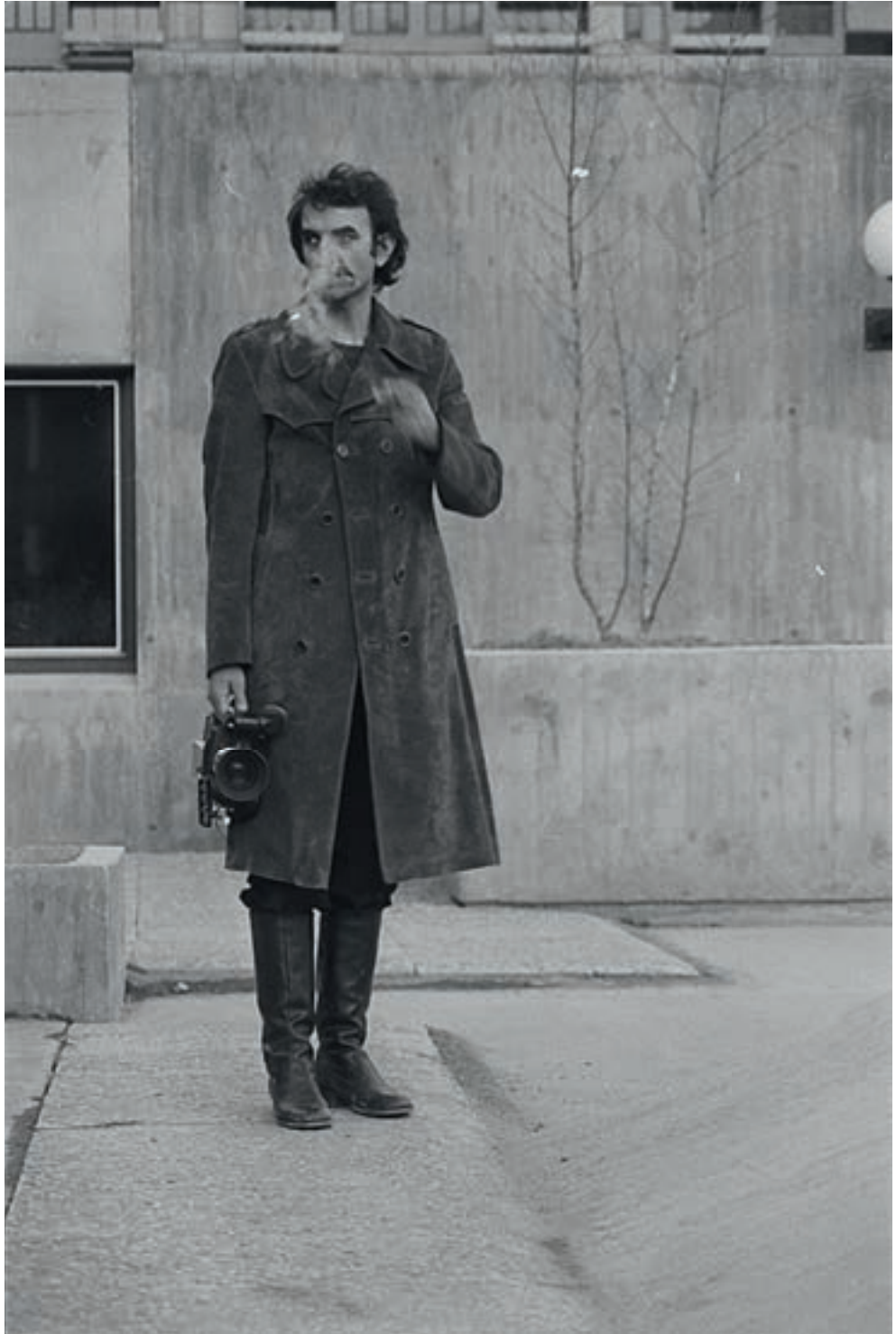

#### CAROLINE CHAMPETIER ET PASCAL LAGRIFFOUL

Director of Photography Caroline Champetier has an impressive filmography that has led her to work with C. Akerman, J.-L. Godard, J. Rivette, C. Lanzmann, A. Gitai, J. Doillon, B. Jacquot, P. Garrel, A. Despleschin, X. Beauvois, A. Fontaine, P. Mazuy, N. Suwa, M. Von Trotta, L. Carax... She has been honored at international festivals: Cesar for Best Photography, Gianni di Venanzo Prize (2011) for *Des Hommes et des Dieux* of X. Beauvois, Camerimage's Grenouille d'Argent and several awards for her work on *Holy Motors* by L. Carax (2012). A retrospective was devoted to her in 2014 at the Cinémathèque Française. She has just finalized the image of *Annette* by L. Carax and is preparing a documentary about C. Lanzmann.

*Directrice de la photographie, Caroline Champetier a une impressionnante filmographie l'ayant amenée à travailler avec C. Akerman, J.-L. Godard, J. Rivette, C. Lanzmann, A. Gitai, J. Doillon, B. Jacquot, P. Garrel, A. Despleschin, X. Beauvois, A. Fontaine, P. Mazuy, N. Suwa, M. Von Trotta, L. Carax... Elle a été honorée dans les festivals internationaux : César de la Meilleure Photographie, Prix Gianni di Venanzo (2011) pour Des Hommes et des Dieux de X. Beauvois, la Grenouille d'Argent de Camerimage et plusieurs prix pour son travail sur Holy Motors de L. Carax (2012). Une rétrospective lui a été consacrée en 2014 à la Cinémathèque française. Elle vient de finaliser l'image d'Annette de L. Carax et prépare un documentaire à propos de C. Lanzmann.*



## Jean-Pierre Beauviala in the *Cahiers du cinéma*: The Story of the Inventor

| Thomas Godefroy

In the second half of the 1970s, the rise of video and television and the new uses they bring about encourage the *Cahiers du cinéma* to integrate into its reflections on image objects and questions hitherto little explored by the film magazine. As written in the editorial of number 285 (February 1978) where this shift is formulated, the idea was at the time "to open a new field of questions concerning the material and technical basis of cinema." It was in this context that between 1978 and 1988 Jean-Pierre Beauviala granted the *Cahiers du cinéma* three major interviews. The founder of Aaton appeared as the ideal interlocutor to approach and deepen these technical questionings, while remaining within the lines and the cinephile imaginary of the magazine.

*Dans la seconde moitié des années 1970, l'essor de la vidéo, de la télévision et les nouveaux usages qu'elles induisent, incitent les Cahiers du cinéma à intégrer à leur réflexion sur l'image des objets et des questionnements jusque-là peu éprouvés par la revue cinéophile. Comme on le trouve écrit dans l'édito du numéro 285 (février 1978) où ce glissement éditorial trouve à se formuler, il s'agissait à ce moment « d'ouvrir un nouveau champ de questions concernant la base matérielle, technique, du cinéma ». C'est dans ce contexte qu'entre 1978 et 1988, Jean-Pierre Beauviala accordera aux Cahiers du cinéma trois grands entretiens. Le fondateur d'Aaton apparaît être l'interlocuteur idéal pour aborder et approfondir ces questionnements techniques, tout en restant dans les lignes et l'imaginaire cinéophile de la revue.*

In the second half of the 1970s, the rise of video and television and the new uses they brought about encouraged the *Cahiers du cinéma* to integrate into its reflections on image objects and questions hitherto little explored by the film magazine. As written in the editorial of issue no 285 (February 1978) where this shift is formulated, the idea was at the time "to open a new field of questions concerning the material and technical basis of cinema." A technical territory that the *Cahiers du cinéma* had just begun to explore, notably through a series of interviews with technicians beginning in issue no 283 (December 1977), with the chief operator Nurith Aviv<sup>1</sup>.

Between 1978 and 1988, Jean-Pierre Beauviala gave the *Cahiers du cinéma* three major interviews<sup>2</sup>, which constituted strong aspects for a long-term technical reflection. The founder of Aaton appears to be for the *Cahiers du cinéma* the ideal interlocutor to approach and deepen these technical questionings, while remaining within the lines and the cinephile imagination of the magazine. Indeed, the creation of the inventor, as it is documented by the *Cahiers*, is entirely placed under the seal of a singular cinematic conception, in the same way as that of the authors celebrated by the magazine. With the slight difference of a creation that was both technical and inventive: cinema machines, and a place to design them. Thus, if it is tempting to see the inventor as an author—in the cinematographic sense, it is just as tempting to make him the author—in the literary sense—of the story of his own enterprise and of his technical research<sup>3</sup>. It is these two aspects, distinctive in my opinion of Aaton's presence in the *Cahiers du cinéma*—inseparable in this context, as in so many others, from the figure of its founder—that ► this text aims to explore.

<sup>1</sup> The series "Rencontres avec des techniciens" continued in issue n° 284 (January 1978) with Renato Berta, then with Bruno Nuytten in issue n° 289 (June 1978).

<sup>2</sup> See annex.

<sup>3</sup> To these two approaches to the notion of author, we could add a third, more prosaic one, which would be that of "author of the *Cahiers du cinéma*"—meaning: member of the editorial team—insofar as the engineer's name has for a time appeared in the statutes of the journal. Jean-Pierre Beauviala joined the management committee of the *Cahiers du cinéma* as of February 1978 (n° 285). He then appears, from n° 297 (March 1979), as scientific advisor in the statutes of the journal, until n° 368 (February 1985). However, it seems, on reading the first part of the interview "Beauviala Story" (, n° 409, June 1977)—and by his own admission—that the engineer's commitment to the editorial board was quite minimal.

First of all, we must begin by emphasizing that the technical narrative carried by Jean-Pierre Beauviala in the *Cahiers du cinéma* is coupled with the narrative of a filmmaker, or at least: of a man caught by a desire for film. A documentary film imagined as a reaction to the urban project of la Villeneuve<sup>4</sup>, in Grenoble, that Beauviala wanted to make with the help of a “concomitant sound” device synchronized to the image:

Basically, I wanted to make a film to wring the neck of Le Corbusier, an okay architect but a reactionary and despicable urban planner. It was a walking pamphlet in the old Grenoble where I live, a district still full of craftsmen at the time (1967). Against the new city project that was being planned. For this film I needed a camera that was completely free to roam the streets and squares of the neighborhood, a pure product of the donkey path according to Camillo Sitte. The image path was bathed in the sound space recorded at the same time by four or five tape recorders distributed in the shops [*sic*], workshops and apartments of friends and neighbors around. At the time it was technically impossible to make such a film. The new town [*sic*] was made, not the film<sup>5</sup>.

Through the various evocations of this film and the device it required, it is, beyond the mere technical aspect, a certain vision of cinema that finds expression. An eminently *political* vision (in the primary sense of the term: which concerns life in the city space), where the cinema machines must allow the user to regain control over the modes of image production and to reveal through the film

the structures of domination of the individual. This reflection on the city seems, moreover, to have determined the location of the Aaton workshops in downtown Grenoble. Workshops that were visible from the street and accessible on foot—in the exact same way as they appear accessible in the pages of the magazine. The engineer’s words and accompanying illustrations put special emphasis on the company’s premises and how it works:

My project, my goal almost, is to express myself through cinema in a way that is as convincing, almost as violent, as if I were to take the viewer by the hand and show him day after day everything that proves my point. On a city, for example, a film must be able to be a means of forcing the viewer to see, hear and feel what he or she, as an inhabitant and in the face of social pressures of all kinds, refuses to see, hear and feel. At work too, the life of Aaton made me want to show the ineptitude of certain practices that are socially accepted as obvious: like separating the work space from other urban living spaces, prioritizing work relationships, freezing them in optimum performance, and many other things that made me and my friends, Rouch and Guattari for example, want to make a film about the Aaton Company<sup>6</sup>.

If it is thus, as *author*, that Jean-Pierre Beauviala will appear in the pages of the *Cahiers du cinéma*, his technical discourse will nevertheless have to be adapted to the readership of a magazine which, in its great majority, is not specialized in the matter. In order to create and maintain interest in issues that sometimes involve a certain degree

<sup>4</sup> La Villeneuve in Grenoble is a large urban complex designed in the mid-1960s and built between 1970 and 1983. In addition to creating housing, this project included the installation of sports and cultural facilities, and saw the creation of a community television channel between 1972 and 1976

<sup>5</sup> BEAUVIALA, Jean-Pierre In “Beauviala story 1/3. Stratégie / Temps. Entretien avec Jean-Pierre Beauviala,” *Cahiers du cinéma*, n° 409, June 1988, p. 72.

<sup>6</sup> BEAUVIALA, Jean-Pierre In “Entretien avec Jean-Pierre Beauviala. 1,” *Cahiers du cinéma*, n° 285, February 1978, p.14.

of technicality. In this respect, it is necessary to underline the rewriting work that has been carried out, from the raw material to what will be published in the *Cahiers*—work shared, regarding the first series of interviews published in 1978, between the editors of the *Cahiers* on the one hand, and the engineer and Suzanne Rosenberg on the other:

**[The *Cahiers du cinéma*] sent us the roughs [transcripts of the interview]. And I remember very well that with Suzanne—Suzanne Rosenberg, who was in charge of the video in Paris [...]—we had extensively reworked the writing, a more written side than what comes out of a raw *interview* [...] because there had been, I think, one or two trips back and forth with the *Cahiers* on the illustrations and on the way the questions and answers were presented<sup>7</sup>.**

More generally, the aim is to give the interviews a tone that Jean-Pierre Beauviala later described as “romanesque [and] technically correct.”<sup>8</sup> About the romanesque dimension, it should be noted here that the narration of the technical invention, notably induced by this rewriting work, will borrow, in substance and in form, from different registers. The publication of the interviews, spread over several issues, resemble the 19th century sagas like the famous *Mystères de Paris* by Eugène Sue, published weekly, and that gave an account, on the singular scale of the protagonists, of the changes that were taking place in society. In the same way, this series of monthly interviews, which describe the milestones in the creation of the company and the technical research that was

carried out, allows us to grasp, at the local level of the Aaton workshops, the global upheavals which then transformed the film industry, and changed it profoundly. And if the narrative occasionally takes the form of a futuristic novel—with, for example, the description of the urban, social and convivial uses that video or television will give rise to, or of the future development of certain<sup>9</sup> technologies—it mainly consists of an initiatory journey rather than an original story.

Initiatory journey for the team of the *Cahiers du cinéma* (that is, for the first interview, Alain Bergala, Jean-Jacques Henry and Serge Toubiana), for whom questioning the material basis of cinema and the technical inventions it requires geographically consists of a “passage to Grenoble,<sup>10</sup>” in Aaton’s workshops. A journey from Paris to Grenoble naturally echoed Jean-Pierre Beauviala’s desire to remain rooted in the center of that city, which will also become an important element of his company’s communication. The motif of the “trip to Grenoble” will thus be used to describe those who will have traveled to Aaton’s workshops to try out their cameras and possibly to begin working with Jean-Pierre Beauviala, as well as to invite others, through advertisements, to try his devices and the economy and aesthetics that they induce:

**Those who come here to Grenoble are cameramen like Jean-Philippe Carson, whom I have already mentioned, or scientific researchers like Jean-Luc Godard, or individuals suffocated by the audiovisual avalanche who also want to use the instrument [...] The people we** ▶

<sup>7</sup> BEAUVIALA Jean-Pierre, “La Communication d’Aaton,” Interview with Jean-Pierre Beauviala conducted by Alexia de Mari and Thomas Godefroy, February 6, 2019.

<sup>8</sup> *Id.*

<sup>9</sup> In this respect, we can refer to the insert “Un Rêve,” that appears in the third part of the first series of interviews, in which Jean-Pierre Beauviala envisages the establishment of a local television station by taking advantage of the infrastructures of the national network. Jean-Pierre Beauviala, “Un Rêve,” In “Aux deux bouts de la chaîne. (Entretien avec Jean-Pierre Beauviala. 3),” *Cahiers du cinéma*, n° 287, March 1978, p.8.

<sup>10</sup> This is the title of the introduction to the first series of interviews, in which Serge Toubiana also looks back at what the trip meant, on a more personal level, to him and to Alain Bergala and Jean-Jacques Henry who traveled with him: “And then the three of us travelled to Grenoble (which represented, by the way, an opportunity to get to know each other better, to have the feeling that we were making a move: taking the train, taking photos, taking stock of a trip, leaving Paris for work, and then deciphering a long 200 typed page text), and we really started the interview.” Serge Toubiana, “Passage to Grenoble,” *Cahiers du cinéma*, n° 285, February 1978, p.7.

see are looking for alternative economic relationships with the cinema, something closer to the economy of barter, to craft economy, to direct political action”.

This relationship between technique and aesthetics—which is eminently political as we have already underlined—naturally brings us back to the film project on la Villeneuve in Grenoble that Jean-Pierre Beauviala wanted to make. Although it will never be filmed, the numerous evocations given by the engineer (the project is mentioned in almost every interview) come to constitute an original story, containing already the essence of Aaton’s future technical research, as well as its business model:

**This non-film is the origin of Aaton: the cat-on-the-shoulder camera, the inscription of time to make images and sounds independent during filming, the simple means to master complex editing, the establishment of workshops in the heart of the city to counter the invading tertiary sector that is killing it. And my predilection for filmmakers who discover themselves through their ramblings in the apparent reality<sup>11</sup>.**

Like all original stories, this story includes a degree of fantasy, as regards the immateriality of the missing film, as well as Beauviala’s comment on the city, and on la Villeneuve more specifically, as “uprooted.” Indeed, his discourse appears in contradiction with the reality of an urban project which, unlike what emerges from his remarks, was precisely designed to break with Le Corbusier’s urban planning<sup>12</sup>, and whose community television channel—the Vidéogazette, which broadcasted

between 1972 and 1976—corresponded to the technical practices Beauviala called for in his first interviews.

It is nevertheless interesting to note that as a preamble to the discussion between Jean-Pierre Beauviala and Jean-Luc Godard, retranscribed in the June/July and August 1983 issues, the latter presented the founder of Aaton as an “architect” (ie: a thinker of the city) whose reflection allowed the creation of technical devices that could be inscribed in a more global narrative that would be that of the history of cinema:

**Jean-Luc Godard. Cameras have always been raised by filmmakers, including that of Lumière—as shown in Langlois’s documentary—who was a painter. And the camera was brought about by Charles Cros, who was a poet ... and the Aaton 16 camera by Beauviala who was an architect, because the others didn’t suit him<sup>14</sup>.**

Yet, far from complementing the business discourse carried by Jean-Pierre Beauviala, this discussion rather complexified the debate. The interview was indeed an opportunity for the two parties—Godard and Beauviala—to discuss “on neutral ground<sup>15</sup>” the failure of the development of the Aaton 8-35, commissioned by the filmmaker: a 35 mm camera that Godard dreamed of being as handy, portable and compact as an 8 mm camera, in order to always have it at hand to film himself images with the same quality as images shot with a movie camera. Although Godard and his technicians were not satisfied with the prototype that was developed, the 8-35 nevertheless served as a basis for the Aaton 35, which was larger than the initial 8-35, but also better

<sup>11</sup> BEAUVIALA Jean-Pierre, “Aux deux bouts de la chaîne. (Entretien avec Jean-Pierre Beauviala.3),” *Ibid*, p. 5.

<sup>12</sup> BEAUVIALA Jean-Pierre, “Beauviala Story 1/3. Stratégie/Temps. Entretien avec Jean-Pierre Beauviala,” *Cahiers du cinéma*, n° 409, June 1988, p.72.

<sup>13</sup> See on the subject: Nicolas Tixier, “Habiter-Filmer. La Villeneuve de Grenoble,” *Duen de Bux*, 2018. URL: <http://www.lafuriaumana.it/index.php/67-archive/lfu-34/783-nicolas-tixier-habiter-filmer-la-villeneuve-de-grenoble> [Online], accessed November 30, 2020.

<sup>14</sup> GODARD Jean-Luc, “Genèse d’une caméra (1ère partie), par Jean-Pierre Beauviala et Jean-Luc Godard,” *Cahiers du cinéma*, n° 348-349, June-July 1983, p. 95.

<sup>15</sup> That is, for this interview, the Parisian premises of *Cahiers du cinéma*: “The scene takes place on neutral ground, in an office of the *Cahiers*, in the presence of Jean-Bernard Menoud, Godard’s assistant on his last three films, and myself, representing the *Cahiers* as a welcoming body.” Alain BERGALA, “Genèse d’une caméra (1ère partie), par Jean-Pierre Beauviala et Jean-Luc Godard,” *Cahiers du cinéma*, *Ibid*.

adapted to market expectations. Although it didn't settle the dispute between the director and the engineer, this interview is interesting in the sense that it reveals the paradoxical nature of Beauviala's company: that of an engineer who defended, through his machines and his business model, a militant and committed vision of cinema, but who also had to take into account the expectations and constraints of the market.

This paradox between the company's policy and more mercantile considerations can be observed in another section of the magazine, namely the advertisements for Aaton, which from issue n° 320 (February 1980) regularly appear, sometimes on two pages. If, like all advertisements, their promotional dimension is undeniable, it would seem fair to say that these advertisements tend more to praise a business model and a technical imaginary open to art, auteur cinema and political commitment, rather than to sell machines whose technical specificities, moreover, remain relatively unspecified. Viewed by Jean-Pierre Beauviala more as an *exercice de style* he did by himself (and sometimes quite hastily, since Aaton did not have a graphic designer or a dedicated communication team), these advertisements thus consisted in several respects of an extension of the comments made during the interviews and make it possible to assert, in a more experimental and plastic way, the identity and founding principles of the company.

In addition to the motif of the trip to Grenoble, certain technical aspects developed by the engineer in the course of his interviews thus reappear in the advertisements. Such as the concept of the "image chain," for example, used to designate the entire

process from the shooting to the broadcasting of the image<sup>16</sup>, and which is found in a 1984 advertisement promoting the Super 16 format and clear marking—it should also be noted that, more than a syntagm, it is an entire concept of post-production, explored in the first series of interviews in 1978, that is asserted here:

**In this way, the [Super] 16 negative becomes the first link in all the channels for the production and distribution of future cinema: heavy fiction projected in 35 mm, medium fiction distributed by cable or high-definition disk, essays and documentaries broadcasted by cassettes and television<sup>17</sup>.**

In addition to the filmmakers whose words meet Beauviala's in the pages of the magazine (Jean-Luc Godard, but also Raymond Depardon, Claudine Nougaret or Éliane de Latour who appear before the 1988 interviews<sup>18</sup>), these advertisements allow Aaton to define a certain cinematic style (a letter from Richard Leacock addressed to Beauviala, and obviously praising the Aaton LTR, is thus reproduced in an advertisement in issue n° 322, in April 1981<sup>19</sup>), and to show a sensitivity to other media such as photography and painting, by referring to various works. Thus, an advertisement dated November 1985<sup>20</sup> and praising (again) the merits of the Super 16 and Super 35 formats, is completely representative of the Aatonian approach to advertisement: It includes a reference to Alfred de Musset ("There's no trifling with love ... of images"), as well as a large-format photograph by the anthropologist Marc-Henri Piault... This, in addition to a new reference to the concept of the "image chain," and to the location of the company's workshops in Grenoble. Finally, on a ►

**16**

This syntagm is indeed used in the titles of the last two parts of the first series of interviews, and the entire discourse. See annex.

**17**

Aaton advertisement "Résolution 1984: Ne pas faire les choses à moitié," *Cahiers du cinéma*, n° 355, January 1984, NP.

**18**

See "Le Marquage du vent. Entretien avec Raymond Depardon, Éliane de Latour et Claudine Nougaret," In "Beauviala Story '1/3,'" *Cahiers du cinéma*, n° 409, June 1988, p. 76-78.

**19**

Aaton advertisement "Du M.I.T une lettre de Richard Leacock," *Cahiers du cinéma*, n° 322, April 1981, NP. In addition to Richard Leacock, the advertisement also mentions other documentary filmmakers who use the LTR, namely Michel Brault, Albert Maysles and Jean Rouch.

**20**

Aaton advertisement "La sagesse inverse les idées reçues," *Cahiers du cinéma*, n° 377, November 1985, NP.

more prosaic level, these advertisements are also linked to the interviews published in the *Cahiers du cinéma* insofar as they are, in a way, the financial counterpart of Jean-Pierre Beauviala's various contributions to the magazine:

**I said to them: 'Ok, in exchange for the massive job you're asking me for—since it was a job—you're going to give me a special price for the ads' [...] And indeed, they gave me a price that was unbeatable compared to normal institutions. It was half, or a quarter. But at the same time, they [the magazine's editorial staff] [...] knew that it would be a plus for the Cahiers, and it was. And some people would say, 'I buy the Cahiers at the newsstand and the first thing I look for is this month's Aaton ad.'<sup>21</sup>.**

In short, the relationship between Jean-Pierre Beauviala and the *Cahiers du cinéma*, formalized for a moment in the statutes of the review, is a win-win relationship that allows each of the parties to expand their respective theoretical, political and commercial ambitions. The pedagogical tone of the engineer, as well as the narration of his career as an inventor, allow the *Cahiers du cinéma* to put into words and deepen their technical questioning, through texts in which even the uninitiated can immerse themselves. It is precisely these same questions, combining technical, aesthetic and political issues, which, certainly more than any other magazine at the time, enabled *Cahiers* to provide Jean-Pierre Beauviala with a valuable space for expression, which gave him the opportunity to expand on the story of his company, on its ideological positioning and its visual identity—both through interviews and advertisements.

21

BEAUVIALA Jean-Pierre, "La Communication d'Aaton," Interview with Jean-Pierre Beauviala conducted by Alexia de Mari and Thomas Godefroy, February 6, 2019.

#### ANNEX: J.-P. BEAUVIALA IN THE CAHIERS DU CINÉMA

Between 1978 and 1988, Jean-Pierre Beauviala gave three major interviews to the *Cahiers du cinéma*, published in several consecutive issues:

> "*Les Machines du cinéma*," where the engineer looks back on his career as an engineer, the founding of Aaton and his various invention projects, and the technical evolutions that were taking place (in video and television in the first place, but also super 8):

- "Entretien avec Jean-Pierre Beauviala. 1," *Cahiers du cinéma*, no 285, February 1978, p. 8-15.
- "La sortie des usines Aaton. Entretien avec Jean-Pierre Beauviala. 2," *Cahiers du cinéma*, no 286, March 1978, p. 4-15.
- "Aux deux bouts de la chaîne. Entretien avec Jean-Pierre Beauviala. 3," *Cahiers du cinéma*, no 287, April 1978, p. 5-17.
- "Le maillon central. Entretien avec Jean-Pierre Beauviala. 4," *Cahiers du cinéma*, no 288, May 1978, p. 16-21.

> "*Genèse d'une caméra*" is an interview in two parts that describes a lively discussion between Jean-Pierre Beauviala and Jean-Luc Godard, in which everyone finds the opportunity to discuss the reasons that explained both the development of the Aaton 8.35, and what led to eventually abandoning the project. The interview is supervised by Alain Bergala and Serge Toubiana. Jean-Bernard Menoud (Jean-Luc Godard's assistant) is also sitting at the table during the first part of the exchange, while during the second part, Romain Goupil (Jean-Luc Godard's assistant on *Sauve qui peut la vie*), Vincent Blanchet (a filmmaker) and Renato Berta (a chief operator who namely used a 8-35 on the shooting of Patrice Chéreau's *L'Homme blessé*) join the discussion:

- "Genèse d'une caméra. 1er épisode," *Cahiers du cinéma*, no 348-349, June-July 1983, p. 94-111.
- "Genèse d'une caméra. 2ème épisode," *Cahiers du cinéma*, no 350, August 1983, p. 45-61.

> "*Cinéma, innovations techniques, recherche – Beauviala Story*," an interview carried out ten years after "*Les Machines du cinéma*," which will provide Jean-Pierre Beauviala with the opportunity to describe the evolution of his company during the past decade, how it worked, the trial with Arriflex and the technical breakthroughs—in particular in terms of editing—promised by computer technology. Out of the three announced, only two interviews will be published.

- "Beauviala story '1/3.' Stratégie / Temps. Entretien avec Jean-Pierre Beauviala," *Cahiers du cinéma*, no 409, June 1988, p. 70-75.
- "Cinéma, innovations techniques, recherche – Beauviala Story '2/3.'" Fausses sorties des usines Aaton et entrées des artistes dans le montage virtuel. Entretien avec Jean-Pierre Beauviala," *Cahiers du cinéma*, no 410, July 1988, p. 53-62.

Because they represent a special moment in the editorial history of the *Cahiers du cinéma*, and because they develop a set of common issues over ten years, the three interviews form a coherent entity. Jean-Pierre Beauviala will also appear in the *Cahiers du cinéma*, more occasionally and/or later on, in the following interviews:

> "Outils et formes. Entretien avec Jean-Pierre Beauviala," *Cahiers du cinéma*, no 325, June 1981, p. 91-95.

> "Changer de paradigme. Entretien avec Jean-Pierre Beauviala," *Cahiers du cinéma*, no 719, February 2016, p. 26-29.

## **THOMAS GODEFROY**

**Après avoir soutenu en un mémoire portant sur les liens entre le cinéma de Georges Franju et la littérature policière du XIX<sup>e</sup> siècle, Thomas Godefroy entame en 2016 une thèse, demeurée inachevée, sur l'émergence des appareils dédiés à un usage « domestique » du cinéma en France. Il a également pu prendre part aux activités du partenariat international Technès, ainsi qu'au programme Beauviatech, avec un intérêt particulier pour l'imaginaire déployé par la firme Aaton dans ses différents supports de communication.**

*After having defended a dissertation on the links between the cinema of Georges Franju and the detective literature of the 19th century, Thomas Godefroy started in 2016 a thesis, still unfinished, on the emergence of devices dedicated to a "domestic" use of cinema in France. He was also able to take part in the activities of the Technès international partnership, as well as in the Beauviatech program, with a particular interest in the imagination deployed by the Aaton firm throughout its various communication media.*



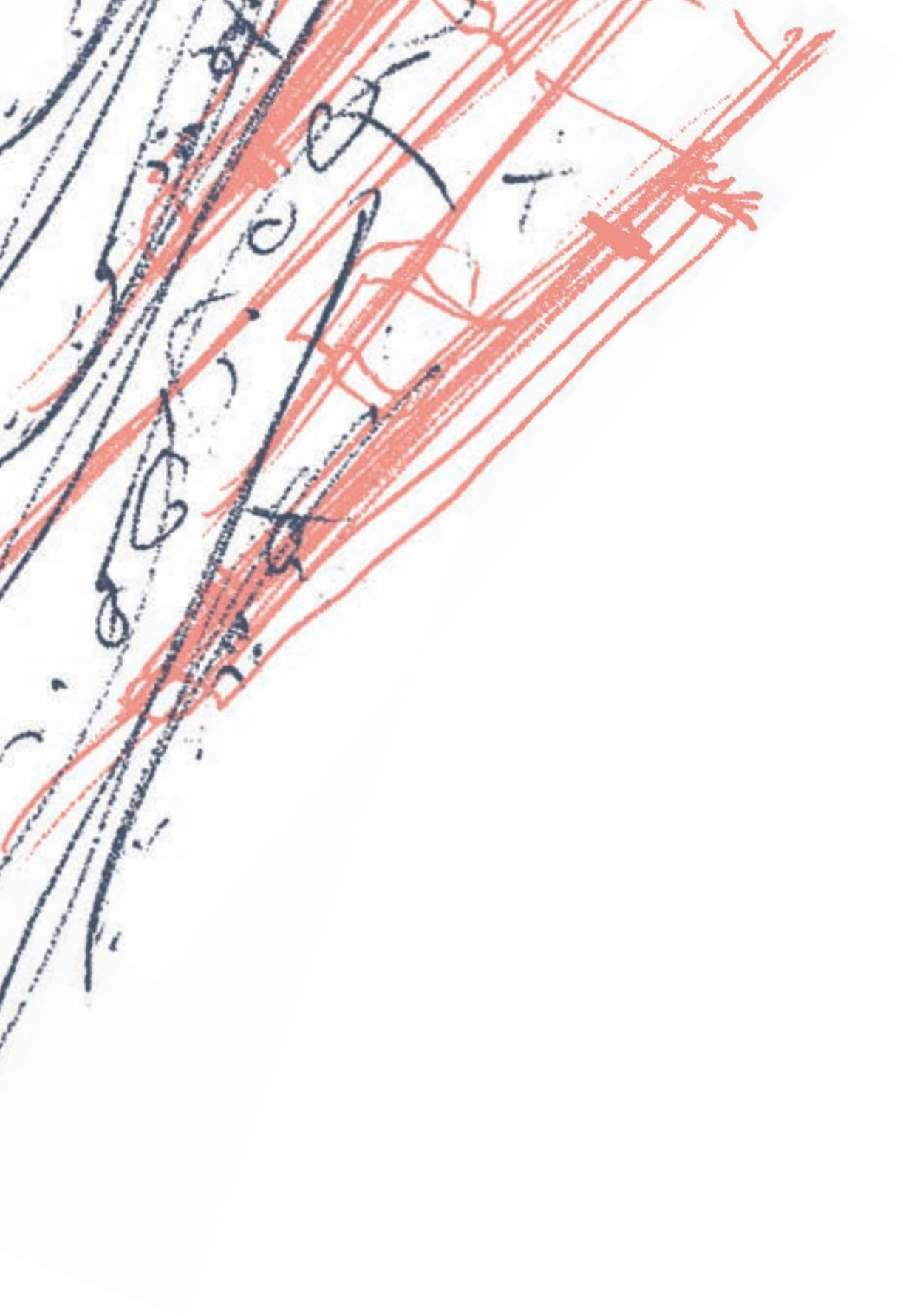

# 4. The Delta Penelope and the Cantar: Experiences and Practices





## The Penelope Delta, the Last Tactile Camera

| Martin Roux

### Abstract

Delta Penelope is the latest camera project developed by Jean-Pierre Beauviala at Aaton, his contribution to the major break between film and digital. Even if the camera was not produced in series, it is a unique tool whose technical description and aesthetic implications are a source of deep reflection on shooting tools.

### Résumé

*La Delta Penelope est le dernier projet de caméra développé par Jean-Pierre Beauviala chez Aaton, sa contribution à la rupture majeure entre argentique et numérique. Même si la caméra n'a pas été produite en série, elle est un outil singulier dont la description technique et les implications esthétiques sont une source de réflexion profonde sur les outils de prise de vue.*

As assistant of Caroline Champetier, I first handled the Penelope Delta in 2013. We had done a multitude of tests to evaluate, with a mix of benevolence and vigilance, if the camera was ready for the shooting of Xavier Beauvois' feature film, *La Rançon de la Gloire*. In the end, the film was shot in 35 mm and the development of the camera was interrupted shortly after. We hadn't managed to produce entirely satisfactory images, especially in comparison with the 35 mm film and its perfectly controlled chain.

After that, I regularly handled the Penelope Delta for tests on different projects, without ever ending up

shooting with it. But this created an intimacy with the device, fueled on the one hand by the challenge of partly overcoming an initial failure, and on the other hand because the manipulation of this camera was so different from the other cameras on the market that it nourished my reflection on shooting devices.

To begin with, it is important to detail the Penelope Delta, its characteristics, the ideas behind its design, whether they were completed or not. Then we will discuss the aesthetic stance of the device.

### An Unconventional Camera

The Penelope Delta is a digital camera that was initially designed to offer an interchangeable digital magazine to the Penelope, the last 35 mm camera developed by Aaton and released in 2008. The development of a digital magazine proved to be a dead end, firstly because the interchangeability was in itself technically very cumbersome (both mechanically and electronically) and secondly because it did not really meet market needs. Indeed, productions and rental companies are very good at accommodating different devices, and mixed silver/digital shootings have always represented a small minority. The project therefore focused on the creation of a hand-held camera, more capable of competing with the strong players on the market (Arri, Red, Sony), within the lines of the Penelope 35 mm and in particular of its optical viewfinder. This viewfinder signs the positioning of the Delta Penelope as the heir of the silver tradition, and distinguishes it from the other digital cameras on the market which, with the exception of the Alexa by Arri, offer devices that are relatively distant from ►

silver-based film. Ergonomics is resolutely focused on the operator's body and gestures: as in the Cantar, the main navigation key is a rotary selector whose different physical positions differentiate various camera functions, allowing purely manual navigation without the need to look at a screen. The rest of the characteristics are equally at odds with the trends at the time.

Aaton opted for a CCD sensor, while the rest of the industry had largely switched to CMOS. The CCD is an analog sensor, which produces an image that is completely discharged from the sensor as an electronic signal. An analog-to-digital converter converts it to a digital image afterwards. On the contrary, CMOS integrates an analog-to-digital converter for each pixel, so the image is digitally recomposed from a sum of separate information. The CCD is more expensive and more difficult to manufacture, and was for a long time of better quality than the CMOS. But advances in microprocessor technology, and efforts to make better CMOS, which were much more suitable for integration into consumer devices (smartphones, cameras), result in the fact that by the early 2010s, the superiority of the CCD was no longer obvious.

The Delta Penelope CCD was manufactured by the Canadian company Dalsa. It offers a 3.5K definition which places it at the top of the digital camera market at the time. The camera has a built in RAW recorder, RAW CineDNG, which is an open format developed by the American company Adobe, sampled in 16 bit and without compression. This makes it by far the most demanding camera in terms of data flow and file size, with an extremely high quality standard. The sensor was set to 640 iso, and had the ability to record a dynamic range

of 14EV. The images are recorded to standard SSD hard drives, as opposed to the trend that leads other manufacturers to develop proprietary media.

In addition, Aaton integrated a number of absolutely unique functions into its camera. To address the need for several native sensitivities for the sensor, Jean-Pierre Beauviala imagined a mechanical shutter with a kind of "louver." A blade with multiple tiny slits can be placed in front of the sensor. This blade, by spinning with the shutter, substracts part of the incoming light in order to reduce the sensitivity of the camera. To improve the texture of the image, Jean-Pierre Beauviala also imagined a device that would allow the photosites of the sensor to be placed differently from one image to another, inspired, from a theoretical point of view, by silver film, where the grains are never positioned in the same place from one image to another. Using a piezoelectric mechanism, the sensor can therefore move a few microns between exposures, providing a slightly different analysis of reality with each image. The vibration is compensated for during image processing by Aaton's software, Ergon, thus generating not an analogon of the silver grain, as it has been said, but actually a finer image, as it produces more spatial information over time. This increases the finesse of the analysis grid.

From my first to my last uses of the camera between 2013 and 2019, the Delta Penelope didn't change. Its development having been stopped in 2013, it has remained as I knew it. On the other hand, the technological environment, the market for cameras and the devices available for the production of cinematic images has evolved considerably, and it appears that it is now much easier to make satisfactory images with the Delta than before. The

camera, whose properties were somewhat unusual, suffered in the first place from difficulties in post-production of the images it recorded. Indeed, in 2013, several calibration softwares did not support cineDNG, and when the format was supported, manipulating the curve to achieve a correct image was tedious. Aaton never made available an extensive range of post-production tools like Arri, Red or Sony did with their own log curves and color spaces. This being said, cineDNG is now widely democratized. BlackMagic Design, the company that develops the Davinci Resolve calibration software has showcased it in its products. As a result, it is now easy to post-produce Delta images with some success.

Thus, the camera was misjudged. Although its performances can sometimes be disappointing, it is far from being useless and can even produce very valuable things.

Unfortunately, the sensor does not have the expected very high dynamic range, the rather high noise level makes the camera much less efficient in low light than its competitors, and it turns out to be generally less versatile than announced. In addition, defects in the finish, in particular in the calibration of the sensor, totally incompatible with series production, and the camera's price well above the competitors made all the defects unacceptable.

But handling the Delta and its images gives insights on expectations about a camera device, on the dominant paradigm in the development of new cameras, and on the relationship between the operator, his gestures and his device.

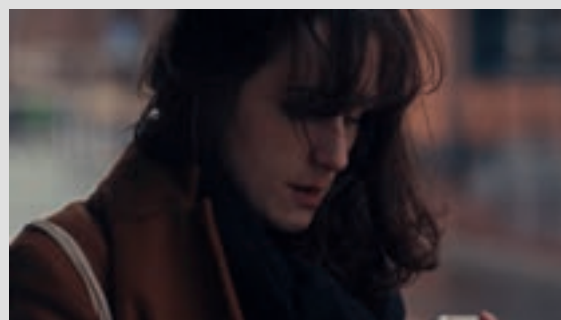
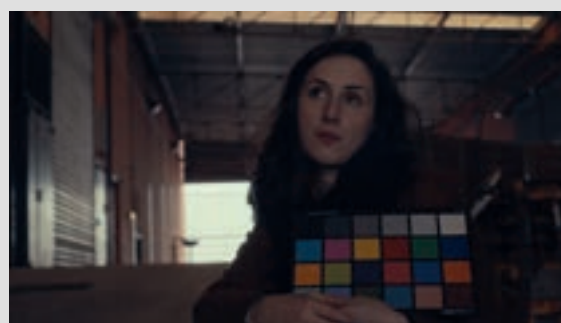
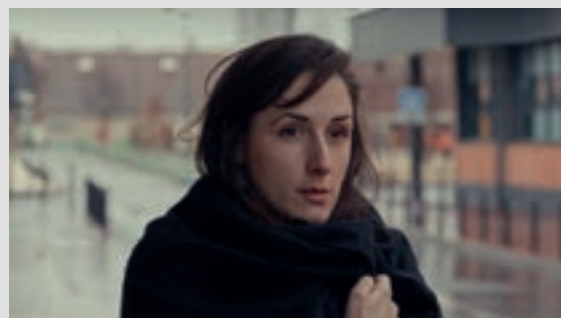

Images extracted from tests shot in 2018, interpreted with BlackMagic Design.

There is a great fineness in the image, a depth and richness of color that can easily be explained by the 16-bit sampling. In daylight viewing conditions, the Penelope Delta works smoothly, the image is easily calibrated and the performance equals the best cameras on the market. The details and texture are different from CMOS cameras, though the difference is very subtle, the precision and roundness is striking when the images are projected.

## Tactile Rather than Digital

The Penelope Delta is an exemplary project of resistance to the digital world. What is striking, in comparison with modern digital cameras, is that for every aesthetic problem that seems to have arisen in its development, a physical, or analog solution was chosen, instead of a pure digital solution. What is at stake in these decisions is the way in which the user, in this case the chief operator, is intellectually solicited. Does he intervene manually, perform physical modulations? Or is his interaction with the tool more abstract and intellectual?

Gilles Deleuze distinguishes between manual, tactile and digital, as three modalities of the eye/hand relationship, in other words the relationship between intellection and gesture, in the pictorial context: “‘Tactile,’ is what I’d call the hand subordinated to the eye. The state of the hand subordinated to the eye. When the hand follows the eye’s commands, then the hand becomes tactile. When the hand shakes off its subordination to the eye. When it imposes itself on the eye, when it does violence to the eye, when it strikes back against the eye—that’s what I’d call ‘properly manual.’

And the digital, on the other hand, is the hand’s absolute subordination to the eye. It’s not even that the hand’s tactile qualities are enlisted in the eye’s service. The hand has dissolved; only a finger remains, for picking between visual binaries. The hand is reduced to a finger pressing on a keyboard. In other words, it’s the computerized hand. It’s the handless finger.

In a way, isn’t that the ‘Ideal?’ But in a very qualified sort of way: the ideal of abstract painting as a pure optical space.<sup>1</sup>”

This trichotomy suits us perfectly to qualify the way the image is made by the operator. The proper manual, i.e. pure physical intuition, exists only marginally, in certain cameraman’s gestures or reflexes, in the context of the cinematographic image. But the tactile and the digital, and the gradation of possibilities that goes from one to the other, describes well the relationship of the operator with the device. From purely mechanical cameras, we have moved towards more sophisticated, but also more abstract devices, with which the operator must make a sum of *binary choices*, as Gilles Deleuze calls them, that condition the internal digital operation of the camera. The camera thus interacts more with the intellect than with the hand. Even the commitment of the operator’s body has shifted. The reflex viewfinder of the analog camera forces the operator to be at one with the camera, whereas the current development of ergonomics oriented towards on-screen framing introduces a distance between the operator and the camera. Without establishing a value hierarchy between these possibilities, it can nevertheless be noted that the design of digital tools is progressively sliding towards the “digital” mode described by Deleuze. The Penelope Delta, as soon as it was released, and today even more so, is a “tactile” UFO.

To the problem of sensitivity, Aaton responds with a shutter, which the operator can put in front of the sensor using a key integrated in the camera. The operator is therefore invited to intervene physically, by his gestures, on the sensor. Aaton offers a physical response to the textural problematic, in an unprecedented way: by making the sensor vibrate, and mechanically operating an aesthetic transformation. Its entire design is an invitation to the manual apprehension of the operator, be it with the rotary selector, the optical viewfinder, or the shape of the camera made to fit the shoulder.

<sup>1</sup> DELEUZE, Gilles, Lecture in Paris 8 on 05/05/81 : [http://www2.univ-paris8.fr/deleuze/article.php3?id\\_article=48](http://www2.univ-paris8.fr/deleuze/article.php3?id_article=48)  
Accessed on 23/09/2020 Transcription : Paula Moore





**In the Delta Penelope proposal, there is the idea that the aesthetic challenge is at the intersection of the gesture and tool. The latter must keep a maximum of shots, or entries, for the hand of the one who operates;**

In the Delta Penelope proposal, there is the idea that the aesthetic challenge is at the intersection of the gesture and tool. The latter must keep a maximum of shots, or entries, for the hand of the one who operates; technical solutions involving the gestures and the body, where the material properties of the camera are superior to digital and abstract solutions. The choice of the CCD also goes in this direction. Unlike CMOS, it produces a complete analog image, outside the field of the digital code, an electromagnetic modulation which integrates the aesthetic properties of the sensor. It is therefore a choice in line with an essentialist conception of the filming medium, a medium from which the cinema image would emerge after its contact with reality, digital technology only having a role of coding and recording this modulation.

There is in the design of the Delta the idea that one can manufacture sophisticated electronic tools without resorting to complex digital manipulations, algorithms for signal optimizations, corrections of noise, sharpness or other settings. There is the principle that the digital intelligence, the calculating capacity of microprocessors, must be used at a minimum, since it is necessary to try to keep the properties of analog electronics intact.

This vision of digital technologies is opposed to the dominant trend of shooting tools, which, generation after generation, are making considerable progress in terms of the computing capacities of their integrated processors, making it possible to increase the performance of sometimes limited components. The most radical example of these advances in digital algorithmic shooting technologies are the cameras integrated into smartphones, whose optical

properties and sensors are considerably digitally corrected to produce satisfactory images. Thus the quality of photos on smartphones increases in proportion to the power of the integrated processors.

In film cameras, likewise, the role of computer science has become increasingly important. The ability to correct color, noise, stability defects or optical aberrations, with algorithms integrated into cameras, has become predominant. As a result, it is difficult to attribute the quality of the images we are given to see to the sensor element alone, or to the performance of the capture process.

The Penelope Delta was therefore an attempt to ward off this trend of moving towards digital, in the Deleuzian sense of the term, cameras. It was meant to be a less abstract and less intelligent tool, computer-wise, a tool supposed to bridge the gap between the operator's gesture and the medium, in a logic very close to the analog shooting devices.

The relevance of this trajectory is questionable, given that several shortcomings seem to compromise the viability of the tool. The shutter louver is supposed to offer a second nominal sensitivity, but it generates optical defects that deteriorate the sharpness of the image. The vibrating sensor, although an exciting and novel approach, does not really solve the problems that camera users may encounter, including texture, and makes the images completely dependent on the interpretation software developed by Aaton. Finally, for several years now, many CMOS sensors have shown a clear superiority over the CCD.



Thus, the idea of manufacturing high-performance tools without massively resorting to digital processing is perhaps illusory, but there are in the Delta, as well as in other cameras made by small manufacturers using CCDs (Ikonoskop, Digital Bolex D16; both in 2K super 16), the demonstration that the dominant paradigm in terms of digital camera design (CMOS, Bayer Matrix, Proprietary Raw, Heavy digital processing...), is only one out of several possible configurations. Today, it makes it possible to manufacture the most versatile and efficient cameras, but perhaps only until the emergence of another paradigm. These different cameras, having relied on the Deleuzian “tactile” rather than the “digital,” produce an image that does not quite resemble the dominant image. It is not necessarily the image sought by all operators and for all films. However it highlights, by its singularity, the aesthetic convergence that exists, conversely, between the images produced by dominant cameras in the market. It demonstrates that this dominant aesthetic does not constitute the whole range of possibilities.

It is through the use of alternative cameras, such as the Delta, that chief operators can take a step back and reflect on their practices, not within the strict framework of the dominant tools but in a more absolute way in terms of the desire for images.

#### MARTIN ROUX

**Martin Roux is director of photography. He graduated from the ENS Louis-Lumière in 2012, and began his career as an assistant to cinematographer Caroline Champetier. In his practice, he is particularly interested in the challenges of image textures. He accompanies his work as an operator with research work on the interface role of the cinematographic image, in a logic of overcoming the silver/digital dichotomy.**

*Martin Roux est directeur de la photographie. Diplômé de l'École Louis-Lumière en 2012, il a commencé son parcours comme assistant de la directrice de la photographie Caroline Champetier. Dans sa pratique, il s'intéresse particulièrement aux enjeux de textures d'image. Il accompagne son activité en tant qu'opérateur par un travail de recherche sur le rôle d'interface de l'image cinématographique, dans une logique de dépassement de la dichotomie argentique/numérique.*

## Optical Viewfinding

Pascal Martin

### Abstract

Aaton's choice for the Penelope and Penelope Delta to keep a reflex sight and not to use a digital sight is part of a tradition of high-tech cinematography. Sighting is an optical instrument in its own right. Its function and principle are recalled in this article which will also seek to understand why, it is still preferred by many operators.

### Résumé

*Le choix d'Aaton pour la Penelope et la Penelope Delta de conserver une visée reflex et de ne pas recourir à une visée numérique s'inscrit dans une tradition de haute technicité cinématographique. La visée est un instrument d'optique à part entière. Son fonctionnement et son principe sont rappelés dans cet article qui cherchera également à comprendre pourquoi elle est encore préférée par de nombreux opérateurs.*

Comparing a ground glass and an LCD screen doesn't make much sense. However, in most digital cameras, the optical viewfinding system has been replaced by an electronic device. While technically it is obviously simpler to achieve, the feeling is eminently different. Once again, the judicious choice made by Jean-Pierre Beauviala on the *Penelope Delta* is understandable.

There is no need to define the importance of the frame, since in the theories specific to the understanding of cinematographic language, it is often the first element that is put forward. Antonioni, Welles, Dreyer, Griffith and so many others have given it particular meanings, but in

all cases a recurrence remains and rests on its technical prerequisite: the viewfinder, the camera operator's tool, which, whatever the technology used, allows him to correlate the filmed object and the recorded image. In the descriptions of cameras or in the works dedicated to them, the viewing systems are rarely detailed, and yet they often reveal a great technicality.

### A Historical Reminder

Without claiming to be exhaustive, it seems interesting to us to review to the main categories of viewfinders. A pioneer in the field of the image, photography, is the first to be concerned with this question. The 19th century wooden chambers worked with a simple principle: a ground glass collected the real image formed by the lens, thus allowing the photographer to achieve his frame and focus. At the moment of the shot, it was replaced by a frame containing the sensitive plate. Of course, everything had to stay perfectly still.

The invention of cinema does not necessarily mark a rupture insofar as, if we refer to the very first cinematographic tapes, the shots are mostly fixed. But as soon as the camera becomes mobile, this *modus operandi* is called into question. The viewfinding device which, however, would come closest to it was, in the 1920s, used on the Parvo-Debrie. The cameraman aimed directly through the film, and he did so behind a black veil so as to block out the light<sup>1</sup>. The image was very dark. When the films were coated with an antihalo layer, this solution became impossible and the camera model that succeeded it, the Super Parvo Debrie, used a mechanism that made it possible to substitute blank film in the print window for ground film where, it should be remembered, the image was inverted top-to-bottom and right-to-left. This modification could only be made when the camera was ►

<sup>1</sup>

People in the profession say that some camera operators wore welding goggles when they weren't viewfinding, to keep their eyes accustomed to the dark behind the camera.

stationary, the frame being defined only at the start of the shot and if the camera was in motion, it was necessary to use an external viewfinder.

There are two types of external viewfinders: the sport viewfinder and the clear viewfinder. The first [Fig. 1] is similar to that used on a firearm. The part near the eye—the *front viewfinder*—must be aligned with a reticle etched on a glass plate or low power lens. It was later replaced by a clear viewfinder operating on the



Fig. 1 : Viseur Caméréclair - La Cinémathèque française

principle of subjective optical systems, of the telescope type, a lens/eyepiece combination. However, these systems have several shortcomings, as they do not take into account the problem of the parallax, i.e. the shorter the distance, the more different what is aimed at is from what is framed. A correction device has been imagined, on different cameras. Let us quote, in 16 mm, the Paillard Bollex H16 and in 35 mm the Mitchell BNC.

## The Reflex Viewfinder

The real technological revolution came with the invention of the reflex viewfinder in 1932 by Erich Kurt Kästner<sup>2</sup>, an engineer working for the Arnold & Richter Group (ARRI). He imagined a hemispherical shutter, rotating, inclined at 45° and equipped with a mirror. It either sends the image back to the ground glass, or lets it through to impress the film. The system is synchronized with the advance of the film and of course with the movement of the claws. From then on, this type of viewfinder has integrated almost all film cameras, including the Penelope and the Delta Penelope. For the latter, a simpler choice could have been made by using an electronic viewfinder, as it is equipped with a sensor. Providing a virtual image to the camera operator, bright, always straightened, is not optically as simple as it seems since before reaching the eye, the image returned by the lens follows a fairly long path and goes through different stages that we will quickly detail. The lens provides a real image on the sensor when the shutter is open. In the closed position, the reflection on the mirror gives a so-called aerial image, difficult to observe because the eye does not know where to accommodate. This is the reason why a focusing screen is placed, the position of which is obviously conjugated<sup>3</sup> to that of the sensor (or film) in relation to the mirror. This element must almost have “schizophrenic” properties, since precision is required (i.e. to materialize the image) but also light (i.e. to allow the maximum amount of light rays to pass through photometrically), two conditions that are at the least contradictory.

While Aaton used a fiber optic focusing screen on the 16 mm Aaton, the choice for the Penelope was an *Aatonite* type focusing screen. It comprises two parts. The first is a 1 mm thick glass plate, on which

<sup>2</sup> The ARRI 35 camera, equipped with this device, was presented at the Leipzig Fair in 1937 and was used by the German army during the war. This clever technical device had already been patented in 1913 by a German, Anton Aretz, but had never been commercialized industrially.

<sup>3</sup> The conjugated term in optics literally means “is the image of,” the focusing screen is therefore the image of the sensor given by the mirror, they are perfectly symmetrical. This incidentally is a check that assistant operators carry out during the aforementioned tests.

the frame markings have been engraved and then filled with fluorescent paint. Chrome was deposited on three of the four sides of the blade, leaving the last one transparent and positioned in front of the Led Aatonite system. This technique offers a perfect and homogeneous diffusion concerning the frame lighting. The glass plate is easily interchangeable depending on the frame format that is chosen. The second part includes the focusing screen itself, on which the central cross has been engraved on the front face of the field lens, its back face obviously being convex. The whole forms a single block.

The field lens has an important function: it redirects the dispersed rays towards the eyepiece in order to ensure a homogeneous illumination of the image that will be observed. This is why it is also known as a “collector lens.” For purists, its exact role is to conjugate the exit pupil of the lens with the entry pupil of the eyepiece. Without it, only the central part of the image would be visible and its periphery would vignette drastically. At the exit of the field lens, begins a long journey where the light meets a whole series of prisms called “rectifiers.” Their intrinsic roles and the complementarity due mainly to their associations are necessary in order to keep a straight image in the viewfinder, whatever the position of the latter.

On the Penelope, the viewing system is special because it is divided into two parts: one is attached to the camera body and the other is located outside (Figure 2). The unit is manufactured by P&S Technik, in Germany. When looking at the camera from the front, it is easy to see that the viewfinder is slightly offset to the left of the lens. As the viewfinder is obviously aligned with the film gate, a system of prisms is optically used for this offset. These are two straight prisms positioned at an angle of 90° to each other. ▶

The external viewfinder forms a “U.” It consists of two plane mirrors aluminized on the surface (two straight prisms would have given the same result) facing each other and arranged symmetrically to one another. Between the two is a Dove prism whose role is to keep

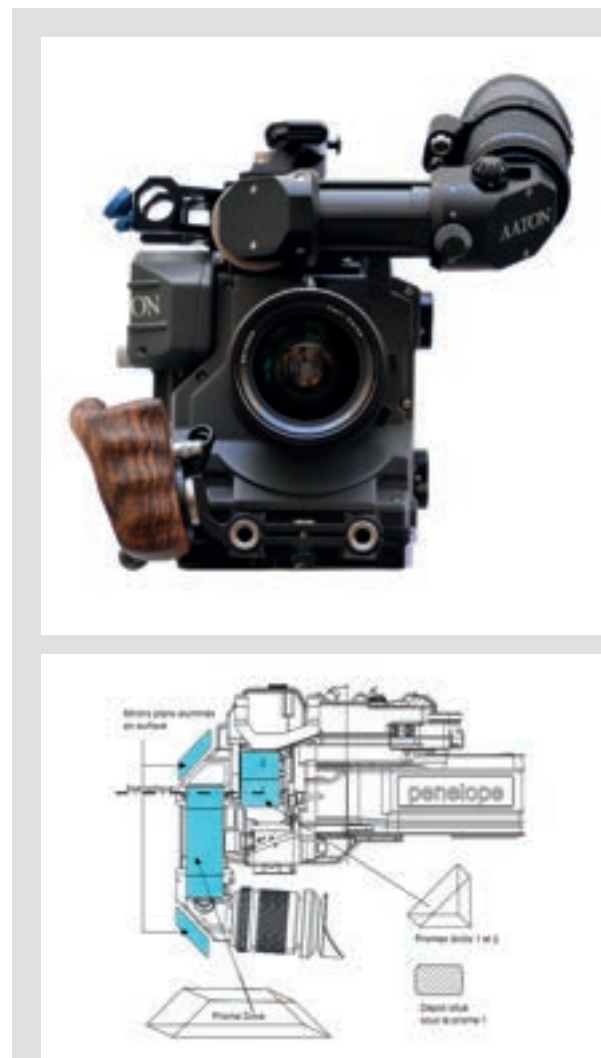

**Fig. 2 et 3 : Penelope 35 mm front view, you can see the viewfinder output is offset from the lens (Source: Aaton. Pierre Michoud)**

the frame horizontal during high and low angle shots. For example, if the cameraman points the viewfinder upwards by  $45^\circ$ , the Dove prism rotates inversely by half of that value, i.e.  $-22.5^\circ$ , if the cameraman points downwards, the Dove rotation will be  $+22.5^\circ$ . This specificity is not recent, it was very quickly integrated into reflex viewfinder cameras<sup>4</sup>, as early as the second half of the 20th century, but it requires a very high mechanical precision in the machining and adjustment of the gears that correlate the movements of the rotating parts. Field lenses are located on either side of the Dove prism which must work in a cylindrical beam. The light then reaches the eyepiece, whose role can be compared to that of a magnifying glass. It is of the dioptric type, (Figure 4), i.e.- it can be used by people with classic visual ametropia (myopia and hyperopia).

The Penelope's viewfinder provides a viewfinder for cameramen with right or left master eyes. The system can therefore perform a rotation of  $180^\circ$  in a horizontal plane<sup>5</sup>. At the top of the viewfinder, an index knob offers the option of rotating the image. The short viewfinder can be replaced by a long magnifying glass which integrates a function of deanamorphosis (not too useful on a camera initially intended to switch from the 3 perforations to 2 perforations formats) in case the lens mounted on the camera would be of anamorphic type. The viewfinder is equipped with a heating device to prevent it from fogging up when the camera is used outdoors.

### Optical or Digital Viewfinder

It must be noted that the optical viewfinder, although it has been used for a long time on all so-called professional analog cameras, is technically



**Fig. 4 : Penelope: dioptric viewfinder with heating system (Source: Aaton. Pierre Michoud)**

more complex to manufacture, to adjust and more expensive for the manufacturer than its digital counterpart where the image of the sensor is taken and sent back on a small monitor placed in front of an eyepiece. Why then keep a technological solution that complicates the manufacturing process, makes it more cumbersome and increases the costs? This point cannot be approached only from a technical point of view, but also requires the integration of some sociological elements<sup>6</sup>.

For many operators, the image provided by the optical viewfinder is more natural. This point is obviously factual, as it comes directly from the lens and is conveyed to the eyepiece without undergoing any alterations other than the nature of the elements encountered. But the optical industry benefits from an immense know-how in the field of lens manufacturing, and the anti-reflective coatings used to guarantee this. The digital image in the viewfinder obviously depends on the compression algorithms, the color balance settings, the associated Lut and, moreover, a very slight delay between what is filmed and what is perceived through the eyepiece which appears to be annoying

<sup>4</sup> Other prisms perform a similar function: Péchan, Abbe...

<sup>5</sup> If optically possible, this is not ideal, as the cameraman's head will then hide the camera's control and command panel.

<sup>6</sup> From a methodological point of view, a complete study will have to be carried out on a representative panel and not only in Europe. The present text is therefore only about considerations and not about results.

for some operators. The very structure of the viewing screen therefore seems to argue in favor of the optical viewfinder, which, by respecting the perception of the image in its depth, allows a better understanding of the ensemble and its contours. Several cameramen say it: the optical viewfinder gives an aesthetic closer to reality. A contrario, working with a real diaphragm is difficult in low light, whereas it is always possible to bring gain to a monitor.

An alternative to eye viewfinding is generally to use a “transvideo” (a small monitor of a few inches in diagonal) mounted on the front of the camera, as is the case on some cameras like the Reds. This device hosts that magic, that closeness that only the camera operators could have with the actors. For it is also necessary to integrate this dimension, where the cameraman was for a long time the first spectator, the first to really see what had just been shot. The monitors on the set provide this specificity to others and mainly to the director. The optical viewfinder provides a special, almost timeless feeling, because nothing tells the user whether behind the lens the recording is done on a sensor or on an emulsion. Doesn't the flicker caused by the shutter (mainly on highlights)<sup>7</sup> create, even unconsciously, a resonance with film projection? Shouldn't we then see in these preferences a generational impact? The fact that Jean-Pierre Beauviala chose this solution is, after all, in tune with his spirit and with the importance he attached to perfection in cinematographic technique as close as possible to those who make the images, never in a technicist logic. Although he was a visionary, he understood perfectly that the transitions in terms of technological progress<sup>8</sup> should not be brutal but that they should be supported as to keep the individual at the forefront. Therefore, we shall leave it to him to conclude:

**7**  
*Ah sacré log quand, tu nous tiens...* See the Weber-Fechner law.

**8**  
It was indeed the hybrid spirit of the original Delta project.

**9**  
Symposium “Métiers et techniques du cinéma et de l’audiovisuel: approches plurielles (objets, méthodes, limites)” at the National Institute of Art History (INHA), Paris, February 12 and 13, 2016.

“I’ve been asked to organize in Port-de-Bouc, near Marseille, for young people, punks who are the same age as the students of the film schools, a screening on a screen with a 10 meter base and not to watch it on shitty little computers. The decision was to use smartphones that the kids know well, and to project on the big screen, because we’ll all be there in a real room in the dark with the magic of screening ... the famous ... Godard triptych and we’ll watch ... we’re not going to turn them into filmmakers, but we’ll make them understand that when we make films, we first do the framing ...<sup>9</sup>”

#### PASCAL MARTIN

**Pascal Martin is a university professor at the École nationale supérieure (ENS) Louis-Lumière where he has been teaching applied optics in photography and cinema since 1984. His research work on depth blurring attempts to find practical and theoretical tools to reinforce the connectedness of the technical, aesthetic and semantic fields of the image. He has also participated in public-private research projects such as Action 3Ds on 3D cinema. He is a member of the Laboratory Paragraphe EA 349 of University Saint-Denis Paris 8.**

*Pascal Martin est professeur des Universités à l'École nationale supérieure Louis-Lumière où il y enseigne l'optique appliquée dans les spécialités photographie et cinéma depuis 1984. Ses travaux de recherche sur le flou/net de profondeur tentent de trouver des outils pratiques et théoriques afin de renforcer la connexité des champs techniques, esthétiques et sémantiques de l'image. Il a participé également à des projets de recherche public-privé comme Action 3Ds autour notamment du cinéma en relief. Il est membre du laboratoire Paragraphe EA 349 de l'Université Saint-Denis Paris 8.*



## The Workshop "Filming with the Delta Penelope"

Giusy Pisano  
Pascal Lagriffoul

Within the framework of a workshop called "Filming with the Delta Penelope," students from the ENS Louis-Lumière and other institutions (Master ArTec, the University of Paris 8, the University of Nanterre) were able to study the characteristics of a mythical camera whose potentialities were tested through filming. The educational objective was to make students aware of the idea that the device is not neutral and that the choice of a camera rather than another determines the images that are filmed. Indeed, it seemed necessary to us to remind future filmmakers and directors of photography of this obvious fact, given that the discourse that has accompanied the development of digital technologies involves an increasingly disembodied perception of the tool. One of the challenges of the workshop was also to reflect on the concept of the *prototype*, which involves the



principle of non-standardization and leaves open technical questions and possible answers. Using the Delta Penelope as an example, students were led to reflect on the digital technological landscape that is gradually imposing norms and standardized practices.

Animated by two professionals (Martin Roux, director of photography and Laurent Ripoli, calibrator) and organized over two days (November 5 and 6, 2019), the workshop was designed as follows:

### Program Day 1:

Two objectives: 1/ A little history of the camera. Archaeology of its characteristics with the handling of cameras. Critical questioning on the properties of the camera: can we prejudge the qualities of a device from these characteristics? How does the uniqueness of the Delta shed light on other available technologies? 2/ Viewing available images with a calibrator. Looking for qualities in the filmed footage that one might expect



of the camera. With the calibrator, asking the question: how do you form an opinion on shooting tools with post-production tools?

After the presentation of the genesis of the camera (technical, aesthetic and political gesture) and the technical characteristics, the students shot images. Their study revealed:

– the richness of color showing a lot of small details in the color of the skin (redness, imperfections) rather distant from the Alexa, in particular;

– but also significant noise problems, in low light and in very saturated colors, as well as problems in the structure of the sensor.

Finally, the calibrated images were screened: this showed that it was only in these viewing conditions that the texture of the camera was revealed and that it was quite remarkable.

### Program Day 2:

From the reflections of the previous day, the objective was to elaborate images to deepen the knowledge of the camera, to try to identify the properties of the CCD by analyzing another CCD camera (the digital Bolex) and to question the role of cameras on texture. In order to compare and contrast the possible singularities and differences, the students used two cameras: the Delta Penelope and the Digital Bolex D16, of a similar design. Then the images produced were studied. Thus, compared to the Bolex, the Delta seemed to suffer from a problem in rendering the most saturated colors. We can assume that the problem lies mainly in the processing of the files, and that it is rather a question of chain and color mapping. This showed the importance of developing chains and of post-production choices: the test of a camera is in fact also the test of the channel that uses its data.

In order to establish a pedagogical assessment, a questionnaire was provided to the students. Here is a summary of the questionnaire:

**1. In the genesis of the Penelope Delta or in these characteristics, what detail(s) caught your attention and seem remarkable to you?**

The common response: *limitation of the intervention of computer science* and preservation as much as



possible of the *raw signal*. Keeping a “raw signal to a maximum allows more control over image processing in post-production.

**2. Is there a place in the industry for devices that have been discontinued, that are out of date, or aging?**

The answers highlight: 1/the opportunity that these “vintage” devices, capable of offering aesthetic singularities, offer to *move away from the standardization of the image* 2/the possibility of experimenting by *hybridizing* them with contemporary devices 3/the usefulness of rethinking the practice and positioning oneself in relation to the current norm.

**3. Does the Delta Penelope convey desires for cinema, for filming, and if so, which ones?**

The answers: the use of the Delta Penelope, one of the rare to use CCD sensor technology in opposition to the ultra massive use of CMOS in the industry, allows: 1/to reflect on the *aesthetic rendering*, the grain, the behavior in high and low lights, the rendering of movements 2/to experiment the limits of the *sharpness of the camera* by filming small elements such as sand and testing the contribution of the non-compression of the image in the rendering of the sharpness of the gradients by filming a sunset for example 3/to test the Penelope Delta camera with a film with a lot of *bright colors and color shades*.

**4. What do you expect from a camera?**

Answers: 1/reliability (that it starts when the key is pressed—which may seem like the minimum, but which has not always been the case in the recent history of digital cameras!) 2/failsafe *security* regarding its storage medium 3/the camera must be the *extension of the operator’s body*, without a complex interface 4/it must have a *particular aesthetic*

*signature*, that reflects the manufacturer’s philosophy of the image.

Generally speaking, this experience with the Delta Penelope and the answers provided by the students underline the need for documentation of the cameras in order to understand the choices that were made in their design. Therefore: knowledge upstream to better understand how the cameras will behave in different situations because, in absolute terms “there are no ‘good’ or ‘bad’ cameras, there are only cameras with given characteristics that will make them the right camera for a given film” (Ariane Vallin, Workshop questionnaire “Filming with the Delta Penelope,” ENS Louis-Lumière, Promotion Cinéma 2020)<sup>1</sup>.

<sup>1</sup> Photographies by Giusy Pisano - All rights reserved

## Learning the Image: From the Camcorder to the Delta Penelope<sup>1</sup>

| Thomas Weyland

### Abstract

All the professionals who speak about the Delta Penelope testify to a very strong attachment for this digital camera. Is it because she had the crazy dream of being able to preserve certain qualities of film? And yet this camera like the camcorder is obsolete. Nevertheless, both could have been tools for learning how to make images. Delta Penelope which, as a prototype, forces us to think about limits, to confront them and find solutions that allow them to be overcome.

### Résumé

*Tous les professionnels qui s'expriment au sujet de la Delta Penelope témoignent d'un attachement très fort pour cette caméra numérique. Est-ce parce qu'elle proposait le rêve fou de pouvoir préserver certaines qualités de l'argentique ? Et pourtant cette caméra comme le caméscope sont obsolètes. Néanmoins l'un comme l'autre ont pu être des outils pour apprendre à fabriquer les images. Delta Penelope, en tant que prototype, oblige à penser les limites, à s'y confronter et à trouver les solutions qui permettent de les dépasser.*

My first images were taken with a Panasonic NV-S7 1992 edition, at the cutting edge of technology at the time of purchase. The images of a small child whose first contact with a camera was through family films.

<sup>1</sup>

These reflections are the subject of my final dissertation at the ENS Louis-Lumière, entitled: *La Delta Penelope: l'image retrouvée* (2020) under the supervision of Éric Guichard and Giusy Pisano.



Panasonic NV-S7 Camcorder

This device has always intrigued me. How could it restore, 20 years later, such precise images and revive the memory of forgotten details? To anyone else, these images would seem bland, unremarkable or shameless, but to me they are extremely precious, because they are at the source of my desire for cinema. Driven by my desire to recover the images of my memories, I chose to study the world of cameras. Over the camcorder of my childhood, I preferred the Delta Penelope. A professional digital camera developed for the cinema by the Grenoble-based company Aaton. Why this choice? Because I was convinced that by studying this camera I would be able to better understand what the rendering of an image consisted of, be it of a professional or an amateur film image, of digital or analog cinema.

This camera, by its unfinished aspect, has something in common with my camcorder; it seems to be able to produce images equivalent to my childhood memories. Memories of images I fantasized about from my old camcorder. The Delta Penelope, like the Panasonic NV-S7, has a digital





Aaton camera: Delta Penelope

CCD sensor<sup>2</sup>. Which means that a camera developed in 2010 is equipped with the same technology used twenty years earlier. However, the Delta Penelope has one notable difference with my father's camcorder: it was never industrially manufactured because it was never commercially available. The invention remained unfinished and marked the end of the Aaton era under the direction of its creator Jean-Pierre Beauviala.

The camcorder also has something else in common with the Delta Penelope: the memory I have of the green grass I played on as a child that corresponds to an unreachable reality, a fantasy. This search for an image, a color, a sensation, a memory; the need to find out what is missing seems to have also been at the origin of the Delta Penelope according to Martin Roux:

“We are beginning to be able to define several forms, and several ways of designing the digital camera. We chose to define two categories of cameras. On the one hand, what we will call “the support-camera,” which attempts to operate

strictly as a sensor, a digital target, and which offers the most transparent coding possible (the Ikonoskop, the Aaton Delta Penelope...). On the other hand, we will call the “computer-camera,” a camera designed around the digital processing of information, which offers a high level of sophistication in terms of colorimetric correction, image “look” and which is organized around an operating system (the Alexa, the Red Epic...)³.

Martin Roux moves even further with the concept of *life of the support* that he exposed in his masters' thesis at the ENS Louis-Lumière:

“Aaton has been developing its digital camera, the Delta Penelope, for several years, trying to integrate a stochastic dimension into the analysis of the sensor. The reflection is as follows: how to make photosites move from one image to the next? The solution that was found by Jean-Pierre Beauviala and his team consists in moving the image sensor from image to image. The sensor therefore moves, perpendicular to the optical axis, to take a position different by a few microns for each image. This results in an increased definition, since of a 3.5K image, Aaton speaks of a 7K image. The process, which is technologically complex, is fully inspired by the concept of silver film. Aaton has, so far, shown few images of the Delta, but the result is indeed very qualitative. The level of detail obtained in the 7K image, although very high, is not too hard, since this definition comes from the complementarity of information, from one image to the next. The movement, based on a piezoelectric system, must be programmed initially. Randomness becomes controlled, and there is undoubtedly a lot to be done in terms of research to analyze the effect of the different possible

<sup>2</sup> Carbonate compensation depth.

<sup>3</sup> *Persistence ou l'influence de l'esthétique argentique sur les technologies numériques*, Final dissertation, ENS Louis-Lumière, 2012, p. 31.

movements. In the end, it is almost astonishing to find only one manufacturer that developed this idea. In addition, Aaton chose a CCD manufactured by Dalsa, an essentially analog processing, and uncompressed recording in a 'DNG' file, i.e. about exactly the same signal chain as the Ikonoskop ACam DII. The camera is therefore inspired at all levels by the concept of the silver image. [...] The stochastic nature of the film thus ensures the total (because unconscious) involvement of the spectator in the reconstitution of a colored environment faithful to his perception of reality. It is also for this colorful phenomenon that Jean-Pierre Beauviala, with Aaton, chose to make the sensor of the Penelope Delta move with each image. To try to obtain subtle variations.<sup>4</sup>

Jean-Pierre Beauviala himself explains this fascination for the randomness that the structure of the silver image allowed, unlike the digital image:

“In silver cinema, from one frame to the next, 24 times a second, you don't have the same light receiver. From one image to another, the sensitive grains are not in the same place and, moreover, they do not have the same size and therefore the same sensitivity. Each point of the image is successively slightly overexposed and then underexposed. The brain therefore has more information to interpret and perceives a more subtle and nuanced image (which is very important for skin tone structure). The random structure of the silver image arouses the emotion linked to this unconscious work of the viewer! On the other hand, in digital, the pixels of the sensor are identical from one image to the other; they do not capture the matter, the depth of colors as analog film does.<sup>5</sup>”

<sup>4</sup> *Ibid.*, p. 31.

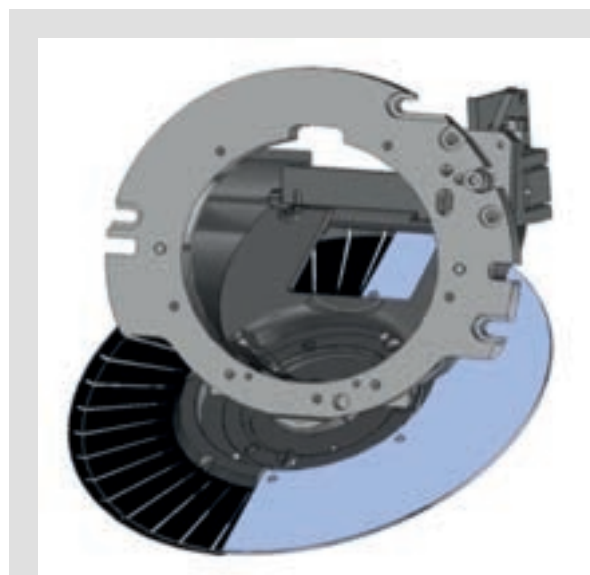

Shutter mirror of the Delta Penelope

All the professionals who comment on the Delta Penelope show a very strong attachment to this camera, to Aaton and to Jean-Pierre Beauviala. Is it because it offered this crazy dream of being able to preserve film in digital with a shutter equipped with a classic rotating half-moon mirror returning the image to the optical viewfinder and dividing by eight the apparent sensitivity of the sensor, or even its flexible device randomly shifting the physical position of the sensor by half a pixel for each image, thus similar to the random positions of the silver halide grains? And yet this camera, like my father's camcorder, is now gathering dust in a closet. Why was Jean-Pierre Beauviala's last invention at Aaton, made within the digital transition, not the success he had hoped for when many professionals agree that this digital camera, the Delta Penelope, has a unique and singular image rendering? And what is this rendering? How do you get it? And why do you want ►

<sup>5</sup> Cited in : *Ibid.*, p. 45.



to get it? Today, the digitization and computerization of cameras have made it difficult, if not impossible, to access the modifications and processing of the raw data recorded directly at the sensor output. This can be explained by the complexity of the digital camera science, which is still finding its way between the sensitometry and colorimetry of the silver world and the signal processing sciences linked to the video world that have been developed in parallel for years. Now, they intersect to meet in the cinema, but the fact remains that this knowledge of the internal image processing of digital cameras remains in the secrecy of their manufacturers in order to avoid industrial espionage. Indeed, intellectual rights (patents) do not protect the code, the algorithmic logic of processing bytes recorded by the cameras, which is developed by computer scientists in the cameras. Recourse to secrecy is therefore necessary. However, Jean-Pierre Beauviala had taken a very different position from that of large multinational companies such as Sony, Arri, Panasonic or Canon. He chose to file a large number of patents for Aaton, but many of those patents were not intended as legal tools, weapons of industrial protection, but as a means of keeping track of his ideas through the processes described in the patents in a very educational way.

### Too Early, Too Late ...

The Delta Penelope never had an official release date, it was never marketed. It remained a *prototype* that could not be manufactured industrially. Under development at Aaton since 2008, it was nevertheless exhibited<sup>6</sup> by its inventor with an Angénieux Optimo 45-120 zoom lens on the stand of another French company, Thalès Angénieux, at the IBC<sup>7</sup> exhibition in Amsterdam in September 2012.

The patent was indeed filed on February 10, 2012, at the INPI (n° 1251263) and a preliminary search report dated July 11, 2012, explains why this patent filed by Jean-Pierre Beauviala was not granted: “The Research Division considers that the present patent application does not meet the requirement of unity of invention and concerns several inventions or pluralities,” in other words: many claims were already known “so that the groups of claims are not linked by a single general inventive concept. The present application does not therefore satisfy the



Jean-Pierre Beauviala and Pierre Andurand, chairman of Thales Angénieux, ENS Louis-Lumière, 2019, GP.

requirements of unity of invention.” Thus, although this patent was refused by the INPI and therefore Jean-Pierre Beauviala’s last idea was not considered an invention, it is nonetheless an innovation. His camera provides insight into the difference between resolution power and definition and offers the operator the possibility to act on the resolution he wants thanks to a setting that is accessible while shooting and that no other camera

<sup>6</sup> FAUER Jon, “Aaton Penelope Delta,” *fdtimes.com*, published: 11/09/2012, URL : <https://www.fdtimes.com/2012/09/11/aaton-penelope-delta/> (consulted on 15/06/2020)

<sup>7</sup> “International Broadcasting Convention.” Every year, this exhibition presents the latest technological innovations in the field of digital broadcasting and television.



offers, even today. Moreover, those who have had the opportunity and the chance to use the Delta Penelope agree that this instrument possesses all the qualities that make it possible to achieve a representation close to reality while at the same time allowing the expression of a very personal vision.

## Weave Your Image

For Jean-Pierre Beauviala, the Delta Penelope was more than just a new camera. Dominique Gentil remembers the first tests at the Éclair laboratory: “Only the red LED in the viewfinder indicated we were shooting. Didn’t that light that didn’t even flicker trivialize the very act of filming? It was as if the word ‘shoot’ became meaningless, the digital camera made no noise. Jean-Pierre, you answered me: ‘Yes, a flicker, but why not a discreet sound like a scroll, or no, better yet, I could add a discreet heartbeat...’<sup>8</sup>”

This *heartbeat*, reminds us that the camera is not an inert object. Of course, it’s obvious, what the image does is what the person behind the camera decides to do with it. The image belongs to the operator, not the machine. And yet, the machine has its share and Jean-Pierre Beauviala and Jean-Luc Godard are well aware of this<sup>9</sup>. “My idea, says Godard in 1983, is that the word is the word of the camera, so to speak, relayed by us, but that we speak the language of the camera and not our own language, applied to a camera.<sup>10</sup>” That is the enormous difference between amateur and professional equipment in this search of the *specific* language of the device. With my old camcorder I

could shoot in all directions to try to get a different image, but my images still represented my “reality.” For the professional that I am becoming, my apprenticeship of the camera language has been deepened thanks to the study of the Delta Penelope which, as a prototype, forces us to reflect on the limitations, to confront them and to find the solutions that allow us to overcome them, even if it means going back and forth.

It is no coincidence that the Delta Penelope refers to Ulysses’ wife and her work, “[that] results from a long and meticulous work” as Jean-Pierre Beauviala said during a meeting at La Fémis in 2012<sup>11</sup>. The fruit of Penelope’s labor was a funeral veil for the death of her father-in-law. A veil that Penelope would weave during the day and unravel at night to start over the next day. All this in order to keep waiting her suitors among whom she would have to choose the one who would replace her husband, who would therefore disappear as soon as she would have finished her work. Unlike Penelope’s work, the Delta Penelope was never completed. But this camera, like the canvas woven by Penelope, seems destined to be unraveled endlessly to allow us to understand the workings of a digital camera with the philosophy of Jean-Pierre Beauviala. The Delta Penelope is a camera that you can use as an apprentice operator.

To study it today is to understand what constitutes a digital camera since digital cameras, although they have unique features, are all designed according to the same computer-digital principle. For that you have to discover it, to put it on your shoulder. A few copies of the Delta Penelope were delivered in late 2012 before its launch at the NAB 2013, but the camera was still not sold. It will only ►

<sup>8</sup> GENTIL Dominique, “Le discret battement de cœur des caméras Aaton,” *La Lettre AFC*, n° 297, May 2, 2019.

<sup>9</sup> See, in this same issue, the text by Vincent Sorrel “Adieu la caméra: la 8-35 et les nuages de *Passion*.”

<sup>10</sup> “Genèse d’une caméra. Episode 1,” *Cahiers du cinéma*, n° 348-349, June-July 1983, p. 94-111. Godard seems to link this search for a simple image to childhood when he explains, in an interview given in April 2019, that the second part of the film *Eloge de l’amour* (2001) finds its origin in a psychoanalysis session that brought back memories of Brittany where he spent part of his childhood. “Entretenir quelque chose qui doit finir...” *Les Inrockuptibles*, n° 120, April 17, 2019.

<sup>11</sup> “Rencontre avec Jean-Pierre Beauviala – 2e journée,” La Fémis, November 22, 2012. GRIZET, Denis, *Les appareils de prise de vues de la société Aaton (1971-2013). Du direct au numérique : enjeux techniques et esthétiques*, Master’s thesis, Université Rennes 2, 2017.

be made available at a few rental companies, which will allow some professionals to have access to it.

As for me, I was also able to test one of these prototypes, that belongs to Panavision, during the workshop “*Filmer avec Penelope Delta*” organized at the ENS Louis-Lumière on November 5 and 6 2019<sup>12</sup>. On this occasion I noticed that its ergonomic quality was faithful to the concept developed by Aaton since its beginnings. This observation was, however, made in a configuration with few accessories, at least not the ones that would have been used for a feature film. If it is subjected to the accessorization of current cameras, it quickly becomes as unergonomic as any other digital camera as soon as it is equipped for a “big film crew” configuration (chief op, cameraman, cam assistant, video assistant...).

The challenge of the tests carried out during the workshop was to handle the device and to form our own idea as to its performance. The tests were carried out to analyze its technical characteristics and not to obtain an artistic result. We watched these images on a computer whose settings we weren’t familiar with, whereas the post-production of the Delta Penelope images requires software developed by Aaton (Ergon) which was used to debug the images and to process the images made with the vibrating sensor. We did not have the software at the time and we used Da Vinci Resolve from Black Magic. Did using other software make the “real” images of the Delta Penelope all the more opaque? What manipulations were made to the “raw” images, those at the output of the sensor before their projection on a large screen? On screen, these images are impressive in quality, after a data processing mastered in post-



production. Similarly, tests carried out previously by professionals underline the quality of the color rendering, especially in overexposure. Caroline Champetier testifies:

“The first images of the Aaton Delta-Penelope on the loose were screened at Éclair on November 17, 2011, in the presence of Catherine Athon, Aude Humblet, Thierry Beaumel, Caroline Champetier, AFC, and Jean-Pierre Beauviala. As a reminder, this camera is the first ‘4K’ camera with an optical viewfinder, recording uncompressed RAW images internally and totally open to anyone who wants to ‘debug’ them, in their own way. Shots in the almost Italian streets of the center of Grenoble, the mountain in the background already snow-covered. It’s all in the picture: the dark facades in the shade, the different colors of plaster, green, yellow or old

<sup>12</sup>

See, in the same issue, the text by Giusy Pisano “The Workshop ‘Filming with the Delta Penelope.’”, p. 150-152.

pink, the blue sky and the snow! There's also the face of a passer-by whose skin touched by a ray of sunshine is absolutely natural, the dynamics are impressive, I have the same exciting feeling as during the testing of the Kodak 5213 two years ago. Then another image, a lime tree of the place des Tilleuls, against a background of a building with pink walls; in the upper center of the image a burst of sunlight touches part of the wall and the yellow leaves of the lime tree, the overexposure of this part of the image is obvious, it does not deteriorate it, but we decide to go and somehow 'investigate' into these whites. Aude Humblet, at the controls of the calibration console, makes a mask, extracts the overexposed part: everything appears in its original color, crossed by the sun, up to the vein of the lime leaves, exhausted by the summer. The overprinting of the masked area on the original part gives a vibrant image of color, beautiful and above all organic. No feeling of ultra-definition, no blurring in the highlights, and not too much contrast. The eye seems to simply believe in the image and the brain follows. I have the feeling that this sensor could make it possible to make images only at the top of the curve, in other words finally the possibility of beautiful overexposures: the curtains of *La Marquise d'O* or the flashbacks of *César et Rosalie*.<sup>13</sup>

In his research work, Denis Grizet raises the question of what they saw and under what conditions in order to affirm that this camera had qualities that no other camera in its time had achieved. He writes on the subject:

<sup>13</sup> CHAMPETIER Caroline, "Vous avez dit organique," *Lettre AFC*, n° 215, published: 11/12/2011, URL: <https://www.afcinema.com/Vous-avez-dit-organique-7356.html>

<sup>14</sup> VARELA S., *Lucy from Paris—Episode 3*, 2013, [<https://vimeo.com/68177637>].

<sup>15</sup> BRAWLEY J., "Aaton Delta Penelope," at johnbrawley: ramblings of a cinematographer, [<https://johnbrawley.wordpress.com/2012/09/17/aaton-delta-penelope/>], published: September 17, 2012.

"We have only been able to see images on a home TV screen, 1920x1080 p definition. The chief operators who have worked with these devices, or who have had the opportunity to see images shot with the Penelope-Delta under optimal projection conditions (i.e. at least using a 4K definition projector) have published reports that we could rely on. However, we must make it clear that the people who have been able to use this device, or to have access to a projection of sufficient definition, are not in an objective relationship with the work of Jean-Pierre Beauviala. Thus, for episode 3 of the series *Lucy From Paris*<sup>14</sup>, entirely shot with this camera, the Aaton Company lent the camera and Beauviala was present during part of the shooting. The compte rendu of cinematographer John Brawley begins with 'Jean-Pierre Beauviala is a bit of a hero to me,<sup>15</sup>' while others work for rental companies that are privileged business partners of Aaton. It can also be noted that several formulations, precise syntagms, diagrams, etc., appear identically on different sites, and even in different languages. Many of the data used in these reports are elements of language taken directly from Aaton's communication, most often from Beauviala himself. It is therefore difficult to differentiate advertising which is related to the Grenoble-based company's natural need to market its product from the personal assessment of experts on a camera. Let us note all the same, for the specific case of the mobile sensor, that it does not seem to convince those who decide to talk about it, even in the presence of Beauviala<sup>16</sup>. If Jean-Pierre Beauviala, Caroline Champetier and Martin Roux<sup>17</sup> all describe convincing results, the

<sup>16</sup> BILLOT Josselin, (chief-operator) In P. HERBOURG and T. HILST, *Making Of Lucy From Paris EP3 - Aaton Penelope Delta*, July 28, 2013 [<https://vimeo.com/71203241>]

<sup>17</sup> It should be noted that he was the assistant of Caroline Champetier, a close collaborator of Jean-Pierre Beauviala. She was also his thesis director at the École nationale supérieure Louis-Lumière. It was during this research that he approached the Delta Penelope.

majority of professionals who show enthusiasm on professional forums have not had the opportunity to test the camera. Very often, it is the desire to defend Aaton as a French exception that dominates, rather than adherence to a technology that could offer new aesthetic possibilities.<sup>18</sup>

Denis Grizet reflects on the assessments made by the chief operators who had the privilege of seeing these images. What did they see or try to see in that camera? Was their assessment really justified or unfounded? On what data can we base our own judgment today? Does the language of operators, as Denis Grizet suggests, take up the “commercial-poetic” language of Jean-Pierre Beauviala or is it Jean-Pierre Beauviala who has acquired the working language of operators? A language that is both poetic and technical and that allows operators to work and communicate their perceptions to make the images they have in mind. For, indeed, the inventor was very attentive to the operators, as he himself says in this interview with Alexia de Mari: “I used to go to cinematographers, I used to go to festivals... I was open to people’s requests because we were far from perfect. The fault of engineers is that they never question themselves.”<sup>19</sup>

Does this poetic and technical language and the complicity that linked Jean-Pierre Beauviala to the operators justify the rejection of what could have been said about the Delta Penelope by people with a positive a priori about Aaton or the inventor? One can hypothesize that if so many professionals have a positive opinion on this camera it may not be without reason. From my personal experience, although limited, I can affirm that this camera offered a very singular rendering, particularly with regard to skin tones.

## Viewfinding and Rendering Color

Denis Grizet’s caution is understandable, hence the critical stance taken during the workshop “Filming with the Delta Penelope.” The properties of the camera were questioned: Can one prejudge the qualities of a device from its characteristics? How does the uniqueness of the Delta shed light on other available technologies? The images produced were also analyzed in order to identify the presumed qualities of the camera, in particular by looking at them with a calibrator to try to answer the question: How to form an opinion on shooting devices with post-production tools? The images filmed and then screened in the projection room of the ENS Louis-Lumière confirmed the comments on color of the professionals who had tested the Delta Penelope years earlier. In 2013, Josselin Billot gave his impressions of the camera:

“The color rendition is bluffing. I’ve never seen such wealth of nuances, and the skin tones are very realistic. The texture of the image is superb, very soft. The dynamic is correct, below an Alexa or a RED in my opinion, around 12 diaph. On the other hand, the rendering of the high lights (clipped) is very bad and it’s quite swarming in the low lights as soon as you stretch the signal a bit. Sensitivity is medium (ISO 640 native)—impossible to change. The slatted shutter system to go down to ISO 80 works well but requires some practice to implement. The sensor displacement system for simulating film grain is not very convincing ... Ergonomics is pretty good, not badly balanced at the shoulder. The optical viewfinder is pleasant but sometimes disconcerting, be careful not to take off the eye! No effective exposure tools in the camera. It is necessary to work on the Astro (on an improved

<sup>18</sup> GRIZET Denis, *op. cit.*, 2017.

<sup>19</sup> DE MARI Alexia, “Entretien avec Jean-Pierre Beauviala, sur le fonctionnement de l’entreprise Aaton,” in *L’équipe de film, innovations et inventions*, under the supervision of Bérénice Bonhomme and Isabelle Labrouillère, article published in issue 2 of *Création Collective au Cinéma*, 2019, p. 214

Rec709 signal...) or on the cell. Some small defects in the overexposed highlights (milling and fringe, sometimes with matrixing...) <sup>20</sup>

From the 2019 tests, the students <sup>21</sup>, including myself, retained above all the first two qualities suggested by Josselin Billot: the *bright colors*, the *shades*, the *texture* of the image, all quite different from those made with the cameras we were used to using. This *difference* was also underlined by Diarra Sourang (Promotion ENS Louis-Lumière 2018) whose research for her final thesis focused on *filming black skin*:

“To support our point, we propose to study the spectral response of another camera: Aaton’s Delta Penelope. This camera has the particularity of offering a very different spectrum from other products on the digital cinema market. First of all, the blue curve is very different from the other two, with a maximum sensitivity of 0.8 in numerical values and gentler slopes before and after this point. The green curve shows the highest peak (1.65), but is closely followed by the red curve (1.60). Unlike Varicam LT, the different curves do not intersect at the same level. The blue and the green intersect at 0.7 in numerical values at 480 nm, the green and the red intersect at 1 in numerical values at 555 nm, as for the eye. The two curves therefore intersect before the skin emission front at 610 nm. The perception of the red appearance of the skin will therefore be different from that of the Varicam LT. <sup>22</sup>”

However, it is in this *gap* with what other cameras offer that we saw the possibility of imagining new

shapes because “we are always looking for new textures and the images of the Delta Penelope do not resemble those we are used to seeing because of the choice of camera designs that are different from those commonly used. The success of a cinematographer in releasing widely a film made with the Delta Penelope would suffice to breathe a new life into it. <sup>23</sup>”

Another element that differs from our habits is the optical viewfinder <sup>24</sup>. It did not pose any major problems: we easily worked with it whereas it is often seen as a difficulty when you are indoors. Éric Guichard, whom we questioned on the subject, explains his interest:

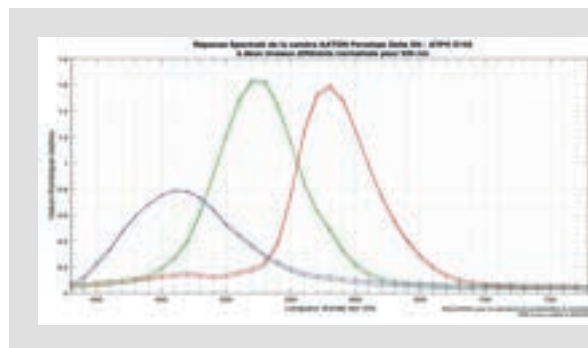

“Putting a neutral filter in front of a camera, we’ve been doing that for years in 35 mm. I’ve shot in 500 ASA in full sunlight and actually put in such strong ND filters that you couldn’t see anything in the viewfinder. First you put on a black sheet, you stay in the dark, you get used to it. It’s really a matter of habit. What I found interesting in the reflex viewfinder was the live report. That is to say that with a digital viewfinder, you have an

<sup>20</sup> BILLLOT Josselin, “Test de la Penelope Delta d’Aaton,” Cinématographie.info, published: 9/06/2013 <https://cinematographie.info/index.php/?topic/3464-test-de-la-penelope-delta-daaton/?s=5200dc6072f6f511d6867cdda7e8d985>. The tests are accessible from these links: *Lucy From Paris* EP3–Test Aaton Penelope Delta <https://vimeo.com/67811891> (consulté le 30/09/2020) *Making Of Lucy From Paris* EP3–Aaton Penelope Delta: <https://vimeo.com/71203241> (consulté le 30/09/2020).

<sup>21</sup> As per the questionnaire completed for this purpose.

<sup>22</sup> SOURANG Diarra, *Filmer les peaux noires*, Final dissertation, ENS Louis-Lumière, 2018, p. 42. See also her book: *Filmer les peaux foncées*, Paris, L’Harmattan, 2019.

<sup>23</sup> VALLIN Ariane, “Questionnaire Atelier ‘Filmer avec la Delta Penelope,’” ENS Louis-Lumière, year 2020.

<sup>24</sup> For more details on the optical viewfinder see, in this issue, Pascal Martin’s text “Optical Viewfinding.”



**Professionals who have had the opportunity to use the Delta Penelope are unanimous on another aspect: the great quality of the camera is that it renders flesh tones faithfully.**

## Rendering Flesh Tones

Professionals who have had the opportunity to use the Delta Penelope are unanimous on another aspect: the great quality of the camera is that it renders flesh tones faithfully.

intermediate and you don't see the real size of the object, and with the monitors you have a delay, very short but even if it's only a few thousandths of a second it's still a delay ... so I'm not even talking about the frame reserve for the field and microphone inputs, it's a disaster. Which is not the case with a reflex viewfinder. But the problem with monitors is that you're out of touch with reality. That is, you no longer touch the object you are filming in the same way. The disappearance of the reflex viewfinder is a great loss to cinema. But I completely understand the young operators, who today no longer work with a viewfinder. They often work at the monitor. There's something else, too. For having noticed it often, I find that the definition of the monitors is very weak, so there are a lot of things that cameramen don't see. A cable hanging around, a shot entry, a shutter too close to the edge of the frame, and they don't see it. They no longer have the shot entries so they don't see when the actors are going to enter the shot, the boom when he arrives is already in the shot. There are a lot of flaws in digital viewfinding, which will eventually be fixed, of course. Little by little, there will be better definitions, reserves, everything will be worked out. At the time we are talking about, digital viewfinders were very poor. And in terms of color, too. Because seeing the colors, seeing the real skin of an actress's face, seeing the real composition of the image and not an interpretation of a monitor that is not necessarily well tuned changes everything. It's more poetic anyway.<sup>25</sup>"

Caroline Champetier also shares this point of view: "The Penelope viewfinder is extraordinary, you just feel like you're in the world. You don't see the world at the end of a hallway."<sup>26</sup>

But what are the differences with the rendering of the skins by other cameras, the Sony or the Alexa for example? Questioned on the subject, Josselin Billot answered:

"It's important to know that the rendering of skins is really a key element for the chief operators. I wouldn't say it's the most important thing, but it's very important to have a natural rendering of flesh tones. The film has always been able to do it very well but never the video, unfortunately. It's a bit of a reference, that is to say that it's always something we look at: the rendering of the skins. It's something you'll hear a lot about: flesh tones. It was one of the strong points of this camera thanks to its CCD sensor which has the big advantage of having a very nice color reproduction. The rendering of the flesh tones was rather nice and so we could exaggerate, we could push the saturation, we could go a little bit to the limit, to the limit to see at what point things turn nasty, at what point the camera jumps and the skin gets all red. It's a good test to push the chroma. There we could push, push, push: it was always natural. Well, it ended up becoming a little fluorescent but it was still beautiful and natural. That was the real highlight."<sup>27</sup>

Some of the comments echo those of Caroline Champetier:

<sup>25</sup> GUICHARD Éric, Interview conducted by videoconference on 15/05/2020.

<sup>26</sup> CHAMPETIER Caroline, Interview conducted by telephone on 21/04/2020.

<sup>27</sup> BILLOT Josselin, Interview conducted by telephone on 13/03/2020.

“From my point of view, what was characteristic of this camera was an infinitely finer, more sampled and less aggressive rendering of colors as compared to all other digital cameras. We found ourselves projected in an organicity of color that reminded us the film a lot. And I acknowledged that when Martin Roux showed us the images he shot of his wife with the Delta Penelope. And I thought the rendering of her skin was extraordinary.<sup>28</sup>”

An opinion she formed on the basis of her tests with a Delta Penelope during the preparation of the film *La Rançon de la gloire* by Xavier Beauvois produced by Why Not Productions. In her words, as in other stories, the recurring idea is that the rendering of the skins by the Delta Penelope reminds her of the silver film. But how were the flesh tones defined in this case? Jean-Louis Fournier explains:

“A system of color reproduction by subtractive synthesis, that of cinema film, imperfect by nature, as we have just seen, requires corrections. Can we improve color reproduction? Should we, and can we improve them all? Is there a privileged color, always present, in cinema? It seems simpler a priori to concentrate on the optimal reproduction of a specific color, which is particularly important for cinema, if it exists, than to try to improve the reproduction of all colors for which the viewer would have no reference to the ‘true’ color. The screenings of many films, feature and short films, TV movies, commercials, documentaries, show that the color present in almost all films is the ‘flesh color,’ the skin tone of the actors. This complexion can be subdivided into three subgroups of Caucasian, African or Asian complexions. The demonstration films of the latest films, Kodak

or Fuji, show us ‘Caucasian, African and Asian’ actors with skin tones, proof that the engineers have particularly applied themselves to obtaining the best possible reproduction of these three skin tones. This implies that the spectator expects a certain reproduction of these flesh tones, that he has a reference skin tone in his brain. If this were not the case, any reproduction of an approximate flesh color would be satisfactory since no comparison would be possible. It is to ensure that a flesh tone memory exists that many studies have been made, especially for the Caucasian flesh tone, the most widespread among actors in the early days of color cinema. To conduct such studies, a statistically average Caucasian complexion had to be determined. This can be done by measuring the various flesh tones of a representative sample and the ‘true Caucasian flesh tone’ can be positioned on the CIE diagram. Finding the ‘Caucasian flesh color of memory’ requires showing a representative sample of spectators a series of colors, a color chart, close to this true flesh tone, and making them choose the skin tone they have in mind. The statistical study of the responses makes it possible to tell whether there is ONE flesh tone memory in the spectators’ memory. It is indeed the case, the set of answers allows to define ONE precise shade for the Caucasian skin tone memory. The problem is that this flesh tone memory does not correspond to the true flesh tone. The dominant wavelength is slightly shorter for the memory flesh tone, 584 nm, than for the true flesh tone, 590 nm, and its saturation is also slightly lower, 20% versus 25%.<sup>29</sup>”

Jean-Louis Fournier insists on the principle of ONE skin. However, there is a wide variety of skin tones. This is the idea defended by Diarra Sourang:

**28**  
CHAMPETIER Caroline, Interview conducted by telephone on 21/04/2020.

**29**  
FOURNIER Jean-Louis, *La sensitométrie : les sciences de l'image appliquées à la prise de vues cinématographique*, Paris, Editions Dujarric, 2006, pp. 108-109, 109.



“The white skin was used as a reference to develop the sensitivity needed to reproduce colors on film. To say that technology is neutral would therefore be a mistake. Nevertheless, the fact that films are the result of a non-inclusive design does not necessarily imply that non-white skins are not reproducible by these emulsions. We notice that the tones [when we look at the distribution of black and white skin tones on the CIE 1931 diagram—Standard observer (2°)] are concentrated on the same area. There is no clear difference between black and white skins, which allows us to introduce the notion of a continuum of skin colors that we will find when we study color charts. Some skins that are supposed to be of different colors are much closer to each other than other skin tones of the same type. The division between black and white is just a figment of the mind. The vast majority of people are neither black nor white, but somewhere in between.<sup>30</sup>”

Thus we will retain that the dominant wavelength of the flesh tones is around 580 nm, which corresponds on the spectral sensitivity curves of the Delta Penelope to the intersection of the sensitivity curves for red and green. This allows a more precise, more sampled capture of the different skin tones. This confirms the judgment of the directors of photography who saw in the Delta Penelope the possibility of a better capture of flesh tones. And that could explain the fact that they felt they had recovered the quality of the film.

“The S cone is loosely isolated with a peak sensitivity at 450 nm, while the M and L cones overlap with peaks of sensitivity around 540 nm for the former and 580 nm for the latter. So we’re not equally sensitive across the spectrum. The

maximum luminous efficiency of the eye is around 550 nm, which corresponds to the intersection of the sensitivity curves of the M and L cones. Thus, we enjoy a particularly precise discriminating power in yellow-greens. A few nanometers more or less can be enough to change our color sensation. Depending on whether it is just before or just after the crossing, the yellow will appear greener or more orange. The skin, white as well as black, reflects primarily long wavelengths, since they involve a lot of yellow and red. Shifting the crossing point of the M and L curves can therefore change the color we perceive of a given skin.<sup>31</sup>”

Unfortunately we could not judge the quality of the skin rendering on the basis of images made with the Delta Penelope, because we did not see the “real” images from this camera. Because, as Diarra Sourang says in her dissertation, a *workflow* adapted for this camera did not exist in 2013:

“The DoP Martin Roux, compares the image of this camera to that of a scanned 35 mm film, for its color depth and the feeling of continuity, ‘as if there were no sampling.’ While specifying that the camera is not a finished product and its defects are numerous outside its field of excellence (e.g. strong noise in the blue, poor management of direct light), he describes the incredible definition offered by the CCD sensor and in particular the fineness of the rendering of the skins. However, until very recently, there was no *workflow* suitable for Penelope Delta files. The colors, however well recorded, could not be reproduced.<sup>32</sup>”

Olivier Garcia, who post-produced the tests made by Eric Guichard with a Delta Penelope during the preparation of the film *Les Saisons* by Jacques

<sup>30</sup> SOURANG Diarra, *Filmer les peaux noires*, Final dissertation, ENS Louis-Lumière, 2018, p. 55.

<sup>31</sup> SOURANG Diarra, *idem*, p. 49-50.

<sup>32</sup> SOURANG, Diarra, *idem*, p. 53.

Perrin, underlines that something was missing in the camera:

“The development of this camera was going in the right direction, but it remained incomplete. There was still development to be done and Jean-Pierre Beauviala knew it. But the problem was that it cost a lot of money. So he had to stop.<sup>33</sup>”

This raises the question of why there was no *workflow* adapted for this camera in 2013 when there were *workflows* adapted to other digital cameras of the time such as the F65 or the Alexa. Aaton’s financial situation did not allow for an additional year of research and development. The Aaton Company was not sufficiently trained in video culture: it should have surrounded itself urgently with the competent people to finish developing the Delta Penelope: “These are know-hows that are completely different. And also at Aaton what happened is that because their research and development section became interested in digital technology rather late, they faced big economic problems.<sup>34</sup>”

To be two at a time, between film and digital, between invention and creation, between the joy of inventing and economic profitability is, as Jean-Pierre Beauviala explains, to live on two beats: “one slow and winding: the clay sketch quietly awaits the founder; the other in a hurry and efficient: to make the invention profitable, to stabilize the encounter too quickly.<sup>35</sup>” And it is the vertigo of this in-between which I discovered with the Delta Penelope.

#### THOMAS WEYLAND

**Thomas Weyland is a recent cinema graduate of ENS Louis-Lumière. For his final dissertation, he carried out research on the image of the Delta Penelope based on the testimonies of several image professionals.**

*Thomas Weyland est diplômé de la promotion 2020 du Master Cinéma à l'ENS Louis-Lumière. Il réalise pour son mémoire de fin d'études un travail de recherche sur l'image de la Delta Penelope à partir des témoignages de plusieurs professionnels de l'image.*

<sup>33</sup> GARCIA Olivier, Interview conducted by telephone on 22/04/2020.

<sup>34</sup> DE MARI Alexia, Interview conducted by telephone on 20/04/2020.

<sup>35</sup> Cited in: FAVEL, Thomas, *L'invention dans les techniques de prise de vue. Genèse d'une caméra : Pénélope*, Final dissertation, La Fémis, juin 2007.

## Handling the Cantar: The Implementation of a Working Gesture

Camille Pierre

### Abstract

The sound recordist's place, the way he/she positions himself/herself and his/her movements are central elements of his/her work. The sound recorder fully plays a role in this appropriation of the space, of the film set, and the development of a work gesture. We will analyze in this article how the specific case of the Cantar, Aaton's digital recorder, leads us to reflect, not only on the way in which it is thought out and how it is appropriated but also, consequently, on the place and role of the apparatus.

### Résumé

*La position de l'ingénieur.e du son, ses mouvements et la manière dont il.elle se situe sont des éléments centraux de son travail. L'enregistreur son joue pleinement un rôle dans cette appropriation de l'espace, du plateau de tournage, et dans le développement d'un geste de travail. Nous verrons dans cet article comment le cas particulier du Cantar, enregistreur numérique d'Aaton, amène à réfléchir non seulement sur la manière dont il est pensé et dont on se l'approprie mais également, en conséquence, sur la place et le rôle de l'appareil.*

To develop the Cantar, the first eight-track digital recorder, Jean-Pierre Beauviala exchanged with various sound engineers and equipment rental companies. Jean-Claude Laureux, Jean-Pierre Duret, Guillaume Sciama, Brigitte Taillandier, Nicolas Naegelen, Jean Umansky, Julien Cloquet, Erwan Kerzanet and Michel Durrande, among others.

The goal was to design a recorder to meet the expectations and a certain "reality" of the sound recording profession. At the beginning of 2002, he presented them with a prototype on which everyone was able to comment. A first model of the Cantar was then presented in Amsterdam at the IBC show in September 2002, before being used in 2003 for the first time on the shooting of *2046* (Wong Kar-wai, 2004). We could discuss the eight tracks, the limiters or the great audio dynamics allowed by the recorder, but what also comes out of the discussions with professionals are the ergonomic qualities of the Cantar and the way they praise them. Sound recording technique is also a "body technique" to use Marcel Mauss' expression. That Daniel Deshays describes as follows: "Working with sound is hand-to-hand work. These are bodies taken face to face, the body of the taker facing the body of the speaker or the sounding body (Deshays, 2006). There's something about sound that can't be kept at a distance."<sup>2</sup> The handling gestures of the recorder, the way in which the device allows and influences movement, are important in the development of the object but also in its integration into the work. Caroline Champetier, cinematographer, describing Beauviala in a program devoted to him on France Culture, says that he had "a kind of ecological thinking, a way of thinking of the world in his objects (...) it is remarkable to make such complex tools, camera, recorder, time marker, thinking about the gestures that will embrace them. He does not only make a product but a reflection on the gesture, his own and the one who is going to live with the tool."<sup>3</sup>

In what way does the Cantar reflect the combination of these two thoughts, the thought of the sound engineer's gesture and that of the machine's designer? We will first look at how Beauviala fed on

<sup>1</sup> By this word I mean the ways in which men, in each society, know how to use their bodies in a traditional way. [...] The body is man's first and most natural instrument. Or more exactly without speaking of instrument, the first and most natural technical object, and technical means of man is his body." Marcel Mauss, "Les Techniques du corps," In *Techniques, technologie et civilisation*, Presses universitaires de France, 2012, p. 366 and p. 366, 375.

<sup>2</sup> DESHAYS Daniel, *Entendre le cinéma*, Klincksieck, 2010, p. 88.

<sup>3</sup> GARBIT Philippe, "Surpris par la nuit - Jean-Pierre Beauviala 2/2 (1st broadcast : 03/10/2007)," *Les nuits de France Culture*, URL: <<https://www.franceculture.fr/emissions/les-nuits-de-france-culture/surpris-par-la-nuit-jean-pierre-beauviala-22-1ere-diffusion-03102007>> (accessed July 28, 2020).

the observations made by the operators with whom he exchanged views and how these discussions were translated into action. Then, we will observe how the engineers apprehended the gestures of sound imagined by Beauviala, how the practitioners appropriated the Cantar. The decisions that determined the shape of the camera, its appearance, give the camera a special status linked to a certain imaginary, what the recorder should look like but also directly to its “reality” and its use.

To carry out this research we will rely on a series of interviews with sound engineers and an audio equipment rental company who have all met Beauviala. These interviews carried out according to the rules of semi-directive interviewing, within the framework of the Technès research program, will allow us to better understand the inventor’s working methods and the individual use of the Cantar by sound engineers. Theoretical, philosophical and sociological works on technology will help us to understand the way in which the device is both the receptacle and producer of an imaginary, but also to better define its status.

### **The Cantar Designed for Sound Engineers Jean-Pierre Beauviala in a Dialogue with the Profession**

If he had already taken an interest in sound, notably through synchronization and time marking, Jean-Pierre Beauviala was mainly known for the manufacture of Aaton cameras. The conversations, as reported by some sound engineers, focused on professional practices on film sets and also on the essential differences that separate the recorders from the cameras.

It was hard to imagine for Beauviala because the way you carry a camera is nothing like the way you carry a tape recorder. Likewise, he found it hard to conceive that the satchel was indispensable. (...) You don’t realize, we told him, we have the camera on our shoulder, we put it on a table, the camera is completely naked, so to speak. For our part, we put the tape recorder on the floor, dogs piss on it, it doesn’t work the same way<sup>4</sup>.

The technical object can only be conceived in an environment that is itself modified by the uses specific to a trade. For sound engineers, the use of a sound cart is often indispensable for cinematographic fictions, since they have to move around with heavy and cumbersome equipment: recorder, HF transmitters and receivers, various microphones, consumables<sup>5</sup>, etc. Documentary films generally require more mobility, it is necessary to be able to record quickly, according to events that are taking place, without responding to a scenario. The recorder is then placed in a “shoulder” bag, in which the accessories, reduced to the bare minimum, are also placed. The Cantar must be able to lie flat and be held vertically to meet the requirements for flexibility and mobility described by Guillaume Sciamia. He built a metal box for himself, in which the connectors are located, to unplug the inputs of his Sonosax mixing console, which he added to his configuration, without having to open the Cantar’s cover.

For Sciamia, the machine must therefore be quickly removable, extractable from the sound cart. If in a car scene he has to go in the trunk, he takes the Cantar on his shoulder, if all of a sudden it’s a shot where he can’t keep his sound cart because he has to run behind the actors, that there’s a steadycam and that things don’t work very well with the Hfs, he can be mobile with the Cantar on his shoulder<sup>6</sup>. ▶

<sup>4</sup> Unpublished interview with Jean Umansky, French sound director, by Camille Pierre in May 2020. Umansky has notably collaborated with Jean-Pierre Jeunet—he was nominated at the Oscars for the sound of *Le Fabuleux Destin d’Amélie* Poulain (2001)—and Étienne Chatiliez. He is one of the founders of Archipel productions, film and TV post-production studios.

<sup>5</sup> Consumables: a set of useful accessories for sound recording such as batteries, american paste and butile used to attach lapel microphones.

<sup>6</sup> Unpublished interview of Guillaume Sciamia, chief operator of French sound, by Camille Pierre in June 2020. In particular, he has worked with Patrice Chéreau and Michaël Haneke. He won the César for best sound for *Indochine* (Régis Wargnier, 1993).

The recorder setup can be changed in a single move. Beauviala had insisted that the cables be oriented downwards to make it easier to disconnect them. The headphone jack is also designed to be accessible and secure in all circumstances. The Cantar has two batteries that can relay one another without interrupting the sound recording. This alleviates the autonomy problems encountered up to then. One can also mention its watertightness, its resistance to shocks with a hard disk mounted on springs, etc. However, the device was heavy and many sound engineers who were interviewed commented on the difficulty of carrying it for a long time without feeling pain. This weight, beyond being a constructive imperative, can be interpreted as the desire to present a professional device and not a “shoebbox” made of cardboard<sup>7</sup>. Its potentiometers have the same diameter as those of the Nagra recorders. Jean Umansky insisted that it should be as big as those of the Nagra IV-S which he was used to<sup>8</sup>. The round screens with the meter levels are also reminiscent of those of its Swiss ancestors.

Several visions thus coexist when the recorder is examined. On the one hand, a legacy from the Nagra family, a history of direct sound in cinema



Aaton Cantar X - Fonds Aaton/Cinémathèque française

accompanied by a certain idea of sound recording. It is a solid, portable and ergonomic device to take everywhere to be closer to sounds, nature and actors. On the other hand, it is the advent of a digital workflow with, among other things, the possibility of recording eight tracks separately and the introduction of powerful software such as Majax<sup>9</sup>. Both are not incompatible, they are ultimately presented as a positioning through desires and a working gesture. These are varying degrees, combinations of choices in the use of the Cantar.

The information taken into account by Jean-Pierre Beauviala makes the Cantar a machine that meets certain professional constraints and sound engineer requirements: to be, among others, fast, discreet and flexible. This makes several of them say that it is a machine adapted to their needs, different from the ones before it, in particular recorders equipped with DAT.

There's something that has always struck me with the Cantar, it's a machine that you can grab with your hand, that you can grasp. I think it was really made to be handled with both hands, both hands of an operator, the eyes of an operator, the back of an operator and so on. It has really completely integrated the existence of the operator inside the machine as a fundamental fact. [...] The second thing that's fantastic with Aaton is that we were in dialogue with Jean-Pierre, he was interested in us, in who was using the Cantar. Even with the hacks that we could do on the machines. It's not just a question of customizing the shape of a button, but of knowing that the machine can allow you to feel good while performing working gestures, to go out and meet work gestures<sup>10</sup>.

<sup>7</sup> This expression is found in various interviews.

<sup>8</sup> “Precisely, the complaint that was made to many other machines was that they had very small keys, especially the Nagra models that succeeded the Nagra IV-S, they had made ridiculous keys. (...) It's like telling someone to do something with their fingers by cutting off their hands, it's absurd.” Unpublished interview of Jean Umansky, french chief sound operator, by Camille Pierre in May 2020, *op.cit.*

<sup>9</sup> Majax: reader and editors of files made by the Cantar.

<sup>10</sup> Unpublished interview of Erwan Kerzanet, French chief sound operator, by Camille Pierre in August 2020. He has notably worked with Jacques Doillon, Amos Gitai and Leos Karax.

One could then say of the Cantar that it reinforces an existing work gesture. It revives the image of the sound engineer in the field, at ease with the machine that accompanies him because it meets the constraints of the film set and the sound production workflow. Moreover, Jean-Pierre Beauviala's innovations and his very own understanding of gestures were also at the source of new work gestures.

hands and to put it on their shoulder to test its maneuverability and the ease with which it can be handled once it is worn. On this subject, Jean-Pierre Beauviala repeatedly insisted on the position of the wrists. It seemed important to him for the new recorder not to “break” them. He decided to place the potentiometers on the central plate so that the chief operator could modulate them with his hands flat. On most other models they are on top, which forces the operator to raise his elbow and twist his wrists.

At the beginning, when you discovered the machine, it was indeed destabilizing. In the end, it was finally more convenient for the hand to be flat like that. It's a more natural gesture, otherwise your hand gets all twitchy. There was a picture of me at the Roque-d'Anthéron where I was recording and Aaton's comment on the picture said: “Look at the position of the hand.” Because I was exactly like a guitarist. It's easier to play guitar with a



Photo taken from the personal collection of Erwan Kerzanet on the set of *Holy Motors* (Leos Karax, 2012) - Thanks to Erwan Kerzanet

## Machine Perception. Sound Engineers Adapt to the Cantar

What appears to be essential or striking about the exchanges Beauviala had with chief sound engineers is not necessarily the multiplication of tracks nor the innovations linked to digital technology but rather the relationship with the user's body itself. The first instinct of sound professionals is to take the machine in their



Julien Cloquet and Jean-Pierre Beauviala with a prototype of the Cantar in the Archipel productions local - Thanks to Claire Simon.

**11**  
 Unpublished interview of Julien Cloquet, French chief sound operator, by Camille Pierre in June 2020. In particular, he has worked with Nicolas Philibert and F. J. Ossang. He is also a sound editor, mixer and one of the founders of Archipel productions, film and TV post-production studios.

**12**  
 Unpublished interview of Erwan Kerzanet, French chief sound operator, by Camille Pierre in August 2020, *op.cit.*

vertical guitar than with a flat guitar even when you don't see the strings<sup>13</sup>.

The comparison between the sound director and the musician is recurrent in the evocation of the manipulation of the Cantar, as with Erwan Kerzanet: "I like it because it's got an accordion aspect to it, there's a musical instrument aspect on the machine."<sup>12</sup> The sound operator plays his own instrument with which he is one. He has to be completely comfortable in his handling until he no longer has to look at the keys he manipulates, just like the guitarist places his hand on the strings. Julien Cloquet refers to a "physical feeling" with the machine that Jean-Pierre Beauviala wanted to create. This brings us back to the special relationship between the sound engineer and his equipment. He listens through his headphones and recorder to the material that it absorbs and that constitutes his work, the sound arrangement of a scene. We find the memory of sound engineers such as Antoine Bonfanti or Pierre Gamet, the insisted upon importance of a work gesture which is designated as the source of sound recording, of writing reality through sounds, a process not determined by technique but by the combination of the arm and the microphone that it holds out, the hand and the keys that it manipulates.

Others speak of learning the machine, of taming it. Jean Pierre Duret expressed his fear that the machine would be too complicated the first time he saw the Cantar<sup>13</sup>. But once learned, understood, the machine becomes a "considerable ally" you no longer part with. Guillaume Sciamia also explains: "It's true that, as with all these computerized machines, there are still a certain number of

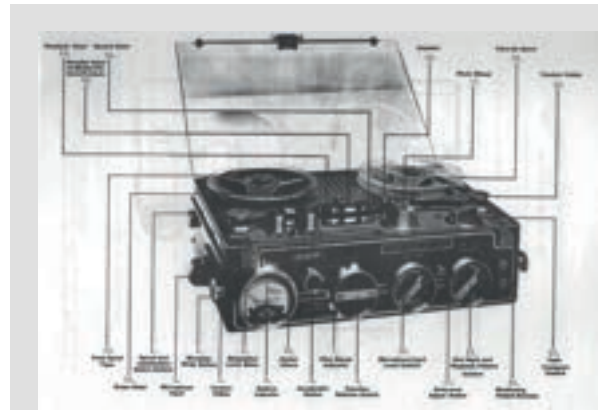

Manuel Nagra III - Thanks to Claire Simon



Aatoncorder - Thanks to Claire Simon

gestures that come back automatically. There's a logic you need to get into your head, to get into your fingers. You don't apprehend it just like that<sup>14</sup>." The machine ends up belonging to the operator, becoming a part of his or her body, setting the operator apart from the film crew with an instrument of expression. For if the sound operator participates in a collaborative work, within a collective at the service of a work, he/she is also the depository of an individual gesture, sometimes obscure to others. All this is inconceivable without revealing a certain vision of sound recording or even a certain image of sound shared by the engineer.

<sup>13</sup> Unpublished interview of Jean-Pierre Duret, French chief sound operator, by Camille Pierre in September 2020. In particular, he collaborated with Maurice Pialat and the Dardenne brothers. He obtains the César for best sound in 2014 for *Michael Kohlhaas* (Arnaud des Pallières, 2013).

<sup>14</sup> Unpublished interview of Guillaume Sciamia, French chief sound operator, by Camille Pierre in June 2020, *op. cit.*

<sup>15</sup> SIMONDON Gilbert, "L'effet de halo en matière technique," In *Sur la technique*, Paris, Presses universitaires de France, 2014, p. 283.

<sup>16</sup> *Ibid*, p. 284.



## The Special Status of the Device, Between Integration into and Extension of the Body: Towards a Totality?

The Cantar is a professional device that is similar to a line of similar recorders. The philosopher Gilbert Simondon calls the “halo effect” a radiance of the technical object that goes beyond its own reality and creates solidarity between things<sup>15</sup>. He gives the example of “Swiss precision”: the mechanical precision of the Swiss watch that shines through the advertising of the Swissair company<sup>16</sup>. In the same way, we can say that the reliability and ingenuity of Nagra recorders have shone on the Cantar through the choices that motivated this solidarity, notably the similarity between the two devices and the emphasis on unparalleled solidity and longevity. Patrice Flichy speaks of series of imaginary images that should not be considered “as the initial matrix of a new technique, but rather as one of the resources that is mobilized by the actors to constitute a reference framework.”<sup>17</sup> This frame of reference is transformed into a framework of use and becomes “common to users and innovators.”<sup>18</sup> All of this reassures the user in the fact that, through this purchase, he adheres to an image, that of a recorder of excellence belonging to a cinematographic history. His gesture joins that of others, before it a transmission of symbols and movements is established.

We can speak here of an instrument according to the definition given by Simondon, that is to say a “technical object that allows the body to be extended and adapted to obtain a better perception; the instrument is a tool of perception”<sup>19</sup>. The instrument is integrated into a mode of sound production, that of the cinema; it is also learned with its own modalities, a previous thought that

it transmits. However, this does not mean that we are facing a form of technical determinism, a machine that induces behavior and thought. It is a link of equality, integration, mediation that links man and machine in Simondon’s thinking. Their relationship even becomes complementary as soon as man accepts himself as an unfinished being and the machine as a being that finds in man its unity, its finality and its link to the whole technical world. The machine appears as the point of coordination “of the two objectifications that define the meaning of human individuation, that of the ‘relationship of the individual to the community’ (sociological objectification) and that of the ‘relationship to the world’ (technological objectification).”<sup>20</sup> Likewise, on the condition that the machine be considered as a cultural being in touch with the community, its representations and its values. The technical object can therefore be seen as a reflection of a mode of representation, of the fragmented expression of an individual caught in a network of cultural norms that is complemented by this technical object. It can only be understood in the light of its genesis. Man cannot make the most of his relationship with the machine without accepting it as part of a mediation, of what connects him to the community and the world. “It is necessary to ‘pull the load’ with it, to know it well, to work with it neither as an end nor as a means, but as a fellow worker and as a complementary being (...) This horizontal relationship must replace any vertical relationships.”<sup>21</sup> The relationship of the human to the world and of the individual to the community passes through the machine. The relationship to the machine is constitutive of human reality and its representations. It is part of a whole, it is essential to the coordination of the whole that constitutes our reality. ►

<sup>17</sup> FLICHY Patrice, *L’Innovation technique*, Paris, La Découverte, 2003, p.179.

<sup>18</sup> *Ibid*, p. 188.

<sup>19</sup> SIMONDON Gilbert, *Du mode d’existence des objets techniques*, Paris, Aubier, 2012, p. 161.

<sup>20</sup> GUCHET Xavier, *Pour un humanisme technologique. Culture, technique et société dans la philosophie de Gilbert Simondon*, Paris, Presses universitaires de France, 2010, p. 22.

<sup>21</sup> SIMONDON Gilbert, “Prolégomènes à une refonte de l’enseignement,” In *Sur la technique* (1953-1983), Paris, Presses Universitaires de France, 2014, p. 253.

To conclude, Jean-Pierre Beauviola inspired himself from the gesture of engineers and inspired them with a work gesture. The recorder is not only a translation of the expectations of a professional body but also the expression of a thought. This thought comes from a heritage, that of analog recorders, as well as the images and sounds of a certain cinema, of sound operators, which adorn the recorder. The device is utilitarian, used for a specific purpose, but it is also related to the person who uses it, part of the mediation between the community and the world. “There’s no use pitting matter against spirit, industry against ideals. In our times, the strength of the instrument is the strength of the mind, and its use implies morality, as well as intelligence.”<sup>22</sup>

Thus we can say that the aesthetic object is not strictly speaking an object, but rather an extension of the natural or human world that remains attached to the reality that bears it; it is a remarkable point in a universe; this point is the result of an elaboration and benefits from technicality; but it is not arbitrarily placed in the world [...]; it maintains an intermediate status between pure objectivity and subjectivity. When the technical object is beautiful, it fits into the natural or human world, like the aesthetic reality<sup>23</sup>.

François Musy, a Swiss sound engineer asked about the Cantar said: “He [Jean-Pierre Beauviola] had sent me a drawing and I told him: “I’ll buy it even if it doesn’t work, I like the drawing.”<sup>24</sup> The human gesture wraps up coordinating this whole between technicality, aesthetics and the world. For Simondon, aesthetic activity is linked to technical activity. The human being is like the conductor who operates among machines, invents them, understands them,

interprets them and thus extends the world by integrating them into it.

#### CAMILLE PIERRE

**Camille Pierre is a doctoral student in cinema at the University of Toulouse II Jean Jaurès in the Lara-Seppia research laboratory. She holds a master’s degree in research-experimentation and sound creation from the ENSAV (École nationale supérieure d’audiovisuel). Her research focuses on collaboration between the various actors involved in film sound and on collective creation. In 2019, she published an article in the journal *Mise au point* on the sound director in the digital age and the technical and aesthetic challenges facing the profession.**

*Camille Pierre est doctorante en cinéma à l’Université de Toulouse II Jean Jaurès au sein du laboratoire de recherche Lara-Seppia. Elle détient une maîtrise en recherche-expérimentation et en création sonore, obtenue auprès de l’ENSAV (École Nationale Supérieure d’AudioVisuel). Ses recherches portent sur la collaboration entre les différents intervenants qui travaillent le son des films et sur la création collective. En 2019, elle a publié un article dans la revue *Mise au point* portant sur le chef opérateur du son à l’ère du numérique et les enjeux techniques et esthétiques auxquels la profession fait face.*

<sup>22</sup> MAUSS Marcel, “Les Techniques et la technologie,” In *Techniques, technologie et civilisation*, op.cit., p. 419.

<sup>23</sup> SIMONDON Gilbert, *Du mode d’existence des objets techniques*, op. cit., p. 258.

<sup>24</sup> “Interview with François Musy—sound engineer,” *YouTube*, Interview filmed as part of the activities of the TECHNÉS doctoral committee with sound engineer François Musy on September 28, 2017 in ÉCAL (Lausanne), URL : <[https://www.youtube.com/watch?v=sn52K\\_wsJHo](https://www.youtube.com/watch?v=sn52K_wsJHo)>. (Ac cessed August 15, 2020)

## The sound of the Cantar: Interview with Jean-Pierre Duret<sup>1</sup>

| Camille Pierre

### Abstract

Jean-Pierre Duret, sound recordist, began his cinematic career with analog recorders before experiencing the digital transition through DAT (Digital Audio Tape) recorders and then, the Aaton digital hard disk recorder, the Cantar. This interview was an opportunity to reflect on the conversations he had with Jean-Pierre Beauviala around the manufacture of the recorder and his own use of the device. Remarks on technique go along with a conception of the profession of sound recordist in connection with an apprehension of the instrument.

### Résumé

*Jean-Pierre Duret, chef opérateur du son, a commencé sa carrière dans le cinéma avec des enregistreurs analogiques avant de connaître la transition numérique par le biais du DAT (Digital Audio Tape) puis de l'enregistreur numérique sur disque dur d'Aaton, le Cantar. Cet entretien a été l'occasion de revenir sur les conversations qu'il a eues avec Jean-Pierre Beauviala autour de la fabrication de l'enregistreur et son utilisation de l'appareil. Les remarques sur la technique s'accompagnent d'une conception du métier de preneur de son en lien avec une certaine appréhension de l'instrument.*

### In what context did you meet Jean-Pierre Beauviala?

I had known him for a long time, not necessarily very personally, but for his cameras, La Paluche

in particular. I was working with a theater group, Armand Gatti's, and at the time we were among the first to use the Paluche, in black and white. I was born in Savoy, he was in Grenoble, he lived in the Trièves, and I went to see him. Then I made a documentary, which interested him, there was a kind of friendly relationship.

### How did you come to sound?

In 1981, Armand Gatti got an advance on earnings for a film. We, the troupe, paid ourselves very little, the salaries in cinema seemed out of all proportion, and he said: "I'll take a cinematographer, a cameraman, a sound engineer, and I'll pay you at your rate, but you'll hire the people I work with. I was told: "You're tall, you'll do the boom." It was as simple as that. Then, I got on very well with the sound engineer, I discovered the movie set, it interested me a lot and so, quite late in life, I got into it, without knowing anything about sound.



Jean-Pierre Duret and Jean-Pierre Beauviala / Photo : Andrea Santana - Thanks to Andrea Santana

<sup>1</sup> This interview was conducted on 4 September 2020.

### **How did you hear about the Cantar?**

I heard about it very quickly, from the beginning, he went all over the networks, to the people he knew and he contacted me, among others. He was known mainly for working on cameras, on film. And so when he came up with that perspective, with the enthusiasm he had and his ingenuity, it was very interesting. But personally I wasn't sure his project would be a quick success. And in the end, the time between the moment he started talking about it and the moment the machine was released was being very short, about four or five years, which is incredible.

### **When the Cantar arrived, what was wrong with recorders?**

In the transition from tape recorders to DAT there was nothing satisfactory, they were semi-professional machines, even if they were still quite reliable. But they were industrially manufactured by large groups, Sony and others, so they weren't suitable for our business. We'd lost something we really trusted with Nagra or Stellavox and Cantar came in to fill the gap.

### **Do you remember the first conversations you had about the recorder?**

We had conversations that revolved around what we wanted, what we needed, what we were longing for so that he could make a machine that was as close as possible to our wishes. We know that every sound engineer is different, the expectations are not the same, but there still are common points. Especially about tracks: wanting diverse sound tracks. We'd always worked in either mono or 2-track. I had already experimented

with working with three synchronous DATs on quite complicated films, where there were a lot of voices, so that made me six tracks in all, not synchronous. We wanted a machine that would give us the benefit of several tracks. On the other hand, we wanted the original quality of the Nagra, the Stellavox: the microphone input preamplifiers, the audio quality. Beauviala could be trusted with that. Then a listening system that is very accurate, efficient, limpid, very clear.

I think that was basically it, after that it was up to individual wishes. We knew he couldn't meet all our needs in one go. But he heard everyone and tried to incorporate everything into a machine that was as nice as possible, as reliable as possible. He really wanted to make a digital sound recording device that would have the same indisputable performance as the Nagra, since the Nagra was better known than the Stellavox, but the two were similar. So a recorder with good limiters and an established sound transparency and limpidity. He got to work.

We already knew how good he was at design, we knew the machine would be very effective, and it was. What we didn't know was that he would be so quick and that it would very quickly be very reliable. This is what imposed Cantar irreversibly when there were other competitors in the world like Zaxcom. But I think the Cantar is unbeatable for many reasons.

What interested me above all is that we perform a craftsmanship profession, so I found it wonderful to find an artisanal machine with French specialists. It was made by a company that was known for its cameras, that many people

had already visited, that I had visited myself and had discovered the “architectural” utopia of this company. All this is part of the Cantar. We feel that we are working with a machine that comes from an old-school industrial model, and not with a purely commercial machine. All mass consumption products today have become a commerce, including cameras. The fact that a camera comes out every three weeks is a sure sign that we are in a commercial logic, which does not meet the fundamental criteria of ergonomics and practicality. So we work with a tool that is reliable and that we handle with pleasure, and I emphasize the word pleasure. It’s very well thought out, it gives a lot of confidence. I try to make a pretty simple sound, respecting the essential part of my job which is really to accompany the director, to try to follow the direction with my sound work. I am convinced that sound is only the emanation of the direction, the actors’ voices, the rhythm. It’s great to have a tool that allows you to accompany this in the best possible way and very simply, it’s great. Of course, when you work with such a tool, a high quality handcrafted product, as soon as you have a problem, you have to call the engineers. Everyone could constantly send information on use and practice to Beauviala.

### **When you first saw it, what were your impressions?**

At first I was scared because I was afraid I wouldn’t know how to use it. Otherwise, my first reaction was about the beauty of the object. The keys, and those three round screens on the X1 that took some time getting used to but proved to be very easy to adopt. It took me a while because of my technical deficiency and my lack of confidence

regarding these things. Fortunately, there are some extremely nice people in the sound business who are willing to spend a lot of time with you, to accompany you, to help you. But it took me a while to get used to it at first.

### **You mentioned the transparency of the sound and the preamplifiers, is this something that differentiates the Cantar’s sound from the sound of the other devices you used to use?**

There is no comparison possible because we never worked without a mixing console when using DATs. They were machines that have no potential at that level, so we had to front them with very good mixing machines on which we just sent the track mixes. Whereas the Cantar is a live mixing tool. Then the later Cantarem<sup>2</sup> accompanied it. You have absolute control over the sound chain from start to finish. After the few adjustments that followed the first machines it became perfect. It gives us a great dynamic, things that are really the basis of our work but which are very valuable because they are set and controlled from A to Z by the same company.

### **Do you feel that this allowed you to record another type of sound? To be more specific about certain things?**

I’m not going to go that far because you can make sound with anything. I’m going to go back a bit to what I was saying before. Agnès Varda used to record sounds for mixing on a small cassette recorder, she didn’t care and she was right. It all depends on where you put your pride. I don’t know if with my little ears I would have been able to hear a real difference between the Cantar and a good mixer before a DAT. I’m not so sure about that. Yes for the purists, for those who do extensive testing, certainly, and of course since the Cantar has all these qualities. But ►

<sup>2</sup>

Cantarem: portable control surface for the Cantar recorder.

let's say that for me that's not the main thing, the main thing is that we had a machine really thought out for us. Made for us, again, in an artisanal way, every part. This gives us great strength, even politically, we are not working with tools that are not thought out for anyone in particular, that are designed to be sold, to do business. That's the big difference. That love you feel for every detail, every curve, the way you think about batteries, how easy they are to use, the fact that they're waterproof, solid, that you can easily transfer your sounds to cards and then transfer them to the sound editing, all those things change your life. When I did *Van Gogh* (Maurice Pialat, 1991), I had my Stellavox on two tapes, I had to change tapes at each take since we were doing ten-minute takes and we had to hurry, we could get mixed up. With the Cantar, you have the memory of everything on the same device, you can find each day of shooting, listen to each take again. There's an extraordinary comfort.

In my opinion, it's a great machine designed on french soil, a very nice tool. I think that the Cantar era corresponds to the end of a certain way of thinking industry, let's not be afraid of words. Then we entered the era of ultraliberalism, practically at the same time, with the twenty-five percent due to the shareholders every year, whereas I am convinced that at Aaton, if they managed to make four percent profit margins each year, they must have been very happy. For me it's a political gesture.

**What do you think of the Cantar's handling, its ergonomics?**

It's perfect. I still have a Cantar X1 in double with the X3, I use it every time I go on the shoulder, when I can't be fixed on a shoot, if I have to go somewhere

quickly, go do a take at full speed. If we have to get into a car or even get stuck in a trunk. I still have my X1, very light, I use all six tracks. I keep it lovingly, I have the number 99 and I'd never want to part with it. I know Aaton doesn't repair it anymore but there are still places with connoisseurs who do, so I keep it preciously and it serves me a lot. It's as good as new and I've never had any problems. Its longevity is proof that it has been well thought out.

**You don't use a mixing console? You are directly on the Cantar's preamplifiers?**

That's it, with the Cantarem. I've got the Cantarem with only eight inputs, I do everything with it. I remain faithful to the one designed by Beauviala which is a thousand times better than the new plastic model. Working with a beautiful object is fantastic. You try to do beautiful work, you can't do that out of an object with a failed design. For everything Beauviala has designed, the design is marvelous: the position of the fingers, the functions, the way he managed to fit it all in such a small space, to make it light, to make the batteries last a long time. I've still got the original batteries for the X1, seventeen years I've had them. I never changed them. It is very different from programmed obsolescence.

**It also brings it closer to the Nagra, to what you were saying, those things that are made to be kept for life, that you get attached to.**

Of course, absolutely. He wanted to make this, the new digital Nagra, a machine made to capture sounds related to fiction or documentary images. He succeeded perfectly. Jean-Pierre was a man who was interested in everything, who was curious, very



**He was a poet, a nature lover, a cévenol, with earthy, peasant roots, a profound ethic, and this ethic can be found in the device he created. In the small factory he established, his workshops, in the heart of Grenoble.**

inventive, on the lookout for anything new, in terms of memory, timecode. He was very close to the movie people. He was also very close to many documentary filmmakers, he did not hesitate to make personal machines for them, adapted to their own needs. He was a poet, a nature lover, a cévenol, with earthy, peasant roots, a profound ethic, and this ethic can be found in the device he created. In the small factory he established, his workshops, in the heart of Grenoble. The relationships he had with cinema, with Jean-Luc Godard, give the guiding principles of his work. He was someone who was interested in films d'auteur, art house and essay films, films that tell stories, films that talk to people. He was very close to that cinema.

**In your relationship to sound recording, how do you view the job of sound engineer on the set?**

Be close to the director, accompany him, help him to go as far as possible in his desires and try to make the sound of the film, and not apply recipes from one film to another. Every movie is different. Here, of course, I am once again talking about films d'auteur, I am not talking about products. Products to make money, for lots of sad and miserable reasons.

The first lesson I received from the sound engineer Bernard Ortion who trusted me in an incredible way when he took me on Gatti's film—since I had never done anything before, I went through it a bit instinctively, with admiration—and I never forgot it is: “the sound doesn't matter, what matters is the movie.” What he meant was that when

you've done what you can and you don't have anything to blame yourself for, if you can't really live up to it, if you can't really make the sound like you'd like it, it doesn't matter, what matters is what's going on in the scene, even if the sound isn't that great.

That's to say that we shouldn't focus on technique, it's the last wheel of the carriage. Technique is fifteen or twenty percent of my job, the rest is the relationship with the actors, with the director, it's listening, it's living with the actors' rhythm, living with their breathing, the way they bring out the words, their tone, the rightness that comes from all that. For the sound an actor is essential, the voice, the finesse. It's the movement, it's the rhythm. The rhythm, the voices that are part of a body, that's the beauty. I have to try to respect this rightness and to incorporate elements that I like, to commit myself to this translation and the Cantar is admirable for that. I'm not a trained technician at all because I didn't go to school. But once I mastered the Cantar, because at first I was afraid of it, it became a considerable ally.

**Did the listening network the Cantar allows for facilitate the circulation of sound on the set? How do you use it in your relationship with the director, actors...?**

I worked with Maurice Pialat, he refused to have headphones on his ears and sometimes he'd even turn his back to the stage and just listen to it, with his ears. He said, “But here we redo, it's bad, it doesn't work.” He hadn't seen the picture, he had just listened to the sound. Listening networks are accessories ▶



that sometimes get in the way. I don't go overboard with that because I'm lucky enough not to make films where we're asked to wear fifty helmets, like some friends who make American movies where sometimes you have to give seventy helmets to people on a set, so there's an assistant dedicated to that. I have seven receptors, I can eventually give seven helmets, most of the time I give four. And a receiver on the video combo. If there are movies that demand more and are interesting why not. But I still maintain that everything that separates us from the core of our profession is illusory. Even dubious. I would say that yes, the technique takes up a lot of space. These five video screens that you can have on a set, it's so heavy, it's impressive. I'm not playing the old cunt, but I would say that the main thing is to maintain a lightness, a closeness with the acting, with the stage and the scene being made, which the Cantar allows. That's what's exciting, apart from that the rest is just superfluous.

**There are reports that sound carts are getting heavier and heavier and are moving further and further away from the actors.**

Not in my case, I have a sound cart and it's not that heavy. I always stay in the room where the actors are, even with a video screen. It still allows me to follow what the camera is doing, it's a pleasant way to mix. Feel the scene, feel the movement of the image. I always try to stay close. I'm actually happy with my sound cart, I've never met a single place I couldn't get into, including a TGV corridor. It's still set up where others work on the shoulder, but I wouldn't be able to because it's too heavy, it would hurt my back. But as soon as there's a need to go to the shoulder I take the X1.

**The Cantar was also the first recorder to offer eight tracks, which was in line with the fact that there were more and more Hfs and we had to find tracks for them. What do you think of transmitter microphones?**

I have a good relationship with transmitter microphones. I try to use them when it is necessary and it is often necessary because there is more and more noise. Then it's a matter of mixing it up. Nevertheless, I don't use them systematically at all. I'm still of the old thinking that you shouldn't give the sound editor everything, even on eight tracks. I don't work with a pre-fader so I only give the sound editor or the production what I've recorded,



Jean-Pierre Duret with the sound cart and the Cantar / Photo : Christine Plenus

what has gone through my ears and not things that are being recorded automatically without me controlling them. I open, I close, I control what I put on my tracks. Even though we can make mistakes, but that's part of the commitment. I think you really have to relay a position to the person that comes next in the sound chain, what you yourself

felt throughout the scene, with its many takes or not, what you tried to convey. This is really done by giving and choosing a direction. That's how the transition between filming and editing can best take place.

**Somewhere you think that it is the scene unfolding before your eyes as it is that will allow to supply the intentions of the sound.**

Yes, it's the way I mix my Hfs and sometimes there is nothing to mix, just a boom. Sometimes the boom can do it all. Sometimes it's a boom with other Hfs. I aim for simplicity, I don't multiply stereo takes or other sound recordings. I'm aiming for a certain kind of transparency, a certain kind of momentum. I'm happy when I get to that and there's finesse and movement in it. That's what I think is important.

**You have both the X1 and the X3, what are the differences to you?**

There are many things that are better, that make our work easier. Now we don't have to do a paper report anymore. Already with the X1 it was no longer the case but it was more complicated to enter the names of the actors, if we got it wrong it was more difficult to go back. With the X3 all this part of the software, the tagging that we have to do, it has become extremely simple, it's very pleasant. We pass on much cleaner things to the editor. It's also the outputs, the ways to go and get a take on a particular shooting day, to output it on a USB key. All this manipulation work has become extremely easy. For my part, I only use twenty percent of the X3's capabilities, the replay for example, I don't know how to use it yet. With the X3, we have a lot more tracks, even though I only work on twelve tracks at most. I've always been able to work with this

little eight input Cantarem and my X3, that's all. I've always managed to do it with that and I'm very happy about it.

**To come back to this idea, of Jean-Pierre Beauviala's belief, of the proximity with a certain conception of cinema, I have the impression that there was also a love of direct sound, to link sound and image.**

It's one of our specialties in France, we're fiercely direct. I've just finished Sandrine Kiberlain's movie, it's a period movie and I don't think there will be anything to dub. It's not a performance, it just happens that I was able to do it. I'm proud of it because the actors were so good, it would have bothered me if we dubbed such high quality things, which bring incredible rightness. I would like to see this rightness respected even if there may be difficulties here and there, small impurities. I'm all for impurities, I'm not at all for uncompromising cleanliness that often makes films too well-behaved. I love direct sound, I fight for it. For a simple reason, there is something precious that is being searched for during a take. If you do six or eight or ten takes, it's not for nothing, it's because there's something the director is looking for and at the tenth take you feel you've reached the end of something, which is precisely what he was hoping for. This, of course, is felt in take ten, which is not the same as take nine. I'm trying to preserve that, to make it work, because there's an original quality that's not going to be there when we tamper with it. Of course we can do very good dubbing and it's even better to say to ourselves that this scene, for a noise issue or something, we'll dub it. Very well. But as long as we can accompany this rightness as best we can... But it's not just that, it's the shoes, the footsteps, the floors. To not ►

systematically put carpeting is to keep a substance, an atmosphere, noises. You can feel that very well with Michaël Haneke, for whom I've never worked, but with him you can really feel the floors, the shoes, the footsteps on the parquet floor, etc. It's part of the image, sound and image are closely intertwined, also with the way he makes his frames.

I feel intimately connected to this, in a very conscious way. So yes, direct sound is something very French after all. It's very respected, you get respect on a film set. Once again, we're still actually talking about cinema. Even if it seems a little pretentious to imagine other films not to be cinema. In any case, I'm talking about movies where there is a "real" director, an author who knows how to use all the tools of cinema to serve his movie, that is to say the sound, the image and all the people who work on a set. I always say that the movie is made of every personality that's on a set, there's no doubt about that. It is in this sense that we do a profoundly artisanal job. People who don't respect that, who don't have that in mind, don't make movies that interest me.



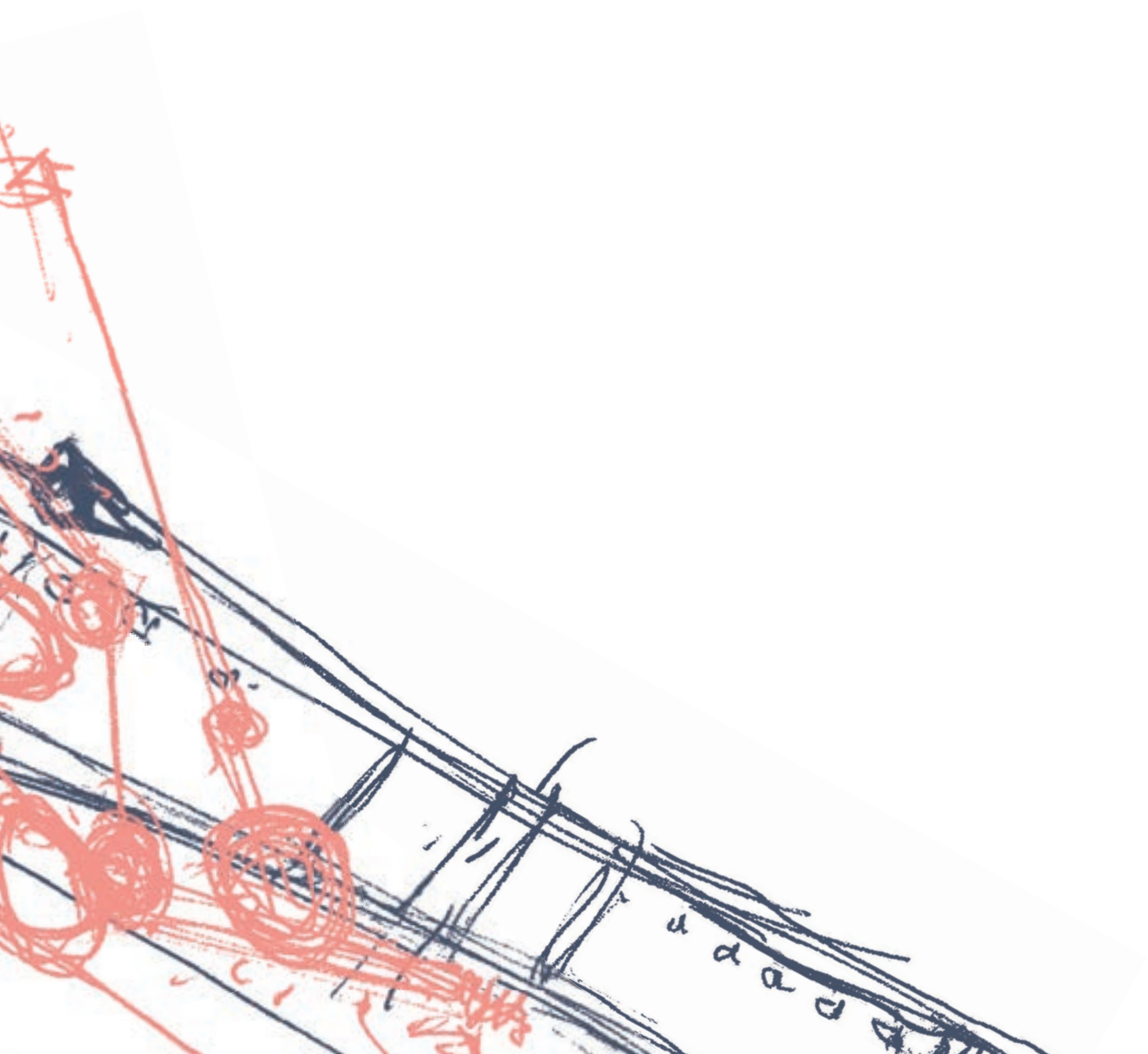

# 5. Invention of New Tools for New Aesthetics







## Experimenting with the Paluche: *Urban Sax in Venice* (1981) by Bénédicte Delesalle and Marie-Ange Poyet<sup>1</sup>

| Hélène Fleckinger

In February 1981, the composer Gilbert Artman and his group Urban Sax performed during the Venice Carnival, through a spectacular performance based on the mobility and breath of about forty musicians. At dawn, on gondolas or along the canals of a cold and rainy city, the camera of the feminist group Inform'elles<sup>2</sup>—a Paluche held by Bénédicte Delesalle and Marie-Ange Poyet—captured the walk of ghostly figures, dressed in white overalls and theater masks, to the continuous rhythm of saxophones, choirs and vibraphone blades. A sort of “Melody in Venice” that Jean-Pierre Beauviala was particularly fond of, both graphic and poetical, *Urban Sax in Venice* embodies in an exemplary fashion the aesthetic and technical possibilities of the Paluche, “a very beautiful instrument of investigation, from unusual angles and with unusual mobility.”<sup>4</sup>

Shot in parallel with a television program made for TF1,<sup>5</sup> this inspired video is a form “of Poaching.”<sup>6</sup> Accepted on the imperative condition of never showing itself in the field of television cameras, the group Inform'elles inserts itself into the heart of the official

filming and the performance itself, thanks to the smallness, lightness and flexibility of the camera. From the outset, a remarkable affinity links the filmed object—the intervention of Urban Sax, known for its work on “spatialization,”<sup>7</sup> its linear and minimal music, an “implacable sound,”<sup>8</sup>—and the Paluche, hailed for its fluidity and the invention of “a new sensation: of having an eye in your hands.”<sup>9</sup> A “video camera whose approaches and framing are no longer those of the shoulder, head and eyes, but those of the arm, hand and fingers,”<sup>10</sup> underlines Jean-Pierre Beauviala: the hand allows for framing impossible to do by eyes and that completely transforms the field of observation. From now on, all it takes is “playing with the fingers to turn the world upside down” and engage “oblique, circular, inverted, extravagant, unstable visions.”<sup>11</sup> During the shooting, the directors experiment with the multiple liberties offered by La Paluche and Urban Sax’s performance becomes a field of visual exploration: characters and objects, bodies and gestures are observed by a camera that is both discreet and curious, a true “third eye,”<sup>12</sup> which reveals a “familiar but unknown field [...] a space never seen before. In any case: never seen like this.”<sup>13</sup> The camera improvises and abolishes distances: it examines a saxophone, follows the choreographed steps of the musicians, at ground level, at knee height, accompanies the procession, interferes in the group, over their heads and shoulders. We get closer, in a striking proximity, we ►

**1** The video, not restored, was put online by Alain Longuet for Grand Canal: <https://www.youtube.com/watch?v=WxH3F6WGLjk>. Many thanks to the directors and to Gilbert Artman for agreeing to answer my questions.

**2** Created in 1980, bringing together female technicians and other female audiovisual professionals, the association Inform'elles is a video structure “responding to the needs of women to express themselves through audio-visual media” (Visual. Des femmes et des images, February 1980, n° 1, p. 11).

**3** Lecture by Jean-Pierre Beauviala at the symposium “Métiers et techniques du cinéma et de l’audiovisuel: approches plurielles (objets, méthodes, limites),” INHA, February 13, 2016.

**4** BERGALA A., HENRY J.-J., TOUBIANA S. and ROSENBERG S., “La sortie des usines Aaton (entretien avec Jean-Pierre Beauviala. 2),” *Cahiers du cinéma*, n° 286, March 1978, p. 13.

**5** The report *Urban Sax vu par François Le Diascom* (16 min) is part of a television program, *Le Miroir de l’autre*, broadcast on TF1 on 2 September 1981, itself associated with an exhibition and a catalog as part of the artistic project *Photoscopies 81*.

**6** FLECKINGER H., Entretien inédit avec Gilbert Artman, Paris, October 15, 2020.

**7** See the band’s website: <https://urbansax.com/>

**8** CAUX D. in POZORSKI I., *Urban Sax*, Paris, Chambre noire/Jannink, 1983, p. 5.

**9** “Aaton Vidéo. Aujourd’hui tout ce que vous voulez savoir sur le système Vidéo Aaton,” undated, p. 2, Aaton Collection, Cinémathèque française.

**10** BERGALA A., HENRY J.-J., TOUBIANA S. and ROSENBERG S., “La sortie des usines Aaton (entretien avec Jean-Pierre Beauviala. 2),” *Cahiers du cinéma*, n° 286, March 1978, p. 13.

**11** DUGUET A.-M., *Vidéo, la mémoire au poing*, Paris, Hachette, 1981, p. 167.

**12** FIESCHI J.-A., “Point de vue sur un troisième œil. Nouveaux cinémas,” *Le Monde*, January 29, 1976.

**13** *Ibid.*

suddenly move away, surprising the group of intrigued passers-by. The camera overhangs the gondolas in full high angle shot, films them under the bridges when they are out of sight, lingers in low angle shots on the musicians who have invaded the docks.

Multiplying shooting angles and rapid axis changes, *Urban Sax in Venice* illustrates what Séverin Blanchet points out about this “different camera,<sup>14</sup>” of which he is the first experimenter with his brother Vincent: “The Paluche allows you to find the optimum shooting angle in relation to the action taking place. All crane movements are permitted! One can move at will from the general to the particular by wide and precise movements?<sup>15</sup>”

No longer located in front of the eye, the Paluche frees the cameraman’s look and allows him to enter into new relationships with the people being filmed: the musicians gradually surrender and begin to play with the camera, until the final image of reversal shows them upside down.

Trained in a classical film culture, the directors show an impressive mastery of shot composition and manage to tame the movements of the hand, avoiding the pitfalls of the extreme maneuverability of the Paluche. Bénédicte Delesalle also explains that she grafted a shelf bracket on the miniature camera as a handle, in order to hold it vertically in the hand and to regain the horizon of traditional cameras<sup>16</sup>. The quality of the Paluche’s video tube, of very good definition and high light sensitivity, reinforces the beauty, density and contrasts of the black and white images of *Urban Sax in Venice*, bearing a mellow and worrying melancholy: “A drop of rain, lost on the lens, becomes a dripping tear and accentuates the winter sadness of a surprising and wet Venice,<sup>17</sup>” writes Dany Bloch.

The sound recorded on site is unusable and the soundtrack is fully post-synchronized. Back in Paris, for the TV show, Urban Sax recorded the music in



*Urban Sax in Venice* (Bénédicte Delesalle et Marie-Ange Poyet, 1981)

one night, at the IRCAM at the Centre Pompidou and Inform’elles got a copy. The editing of *Urban Sax in Venice* is then carried out at the video department of the École nationale supérieure de Saint-Cloud, under semi-clandestine conditions. The directors then decided to break the chronology of the wanderings in Venice and to put together images and sounds, gestures and breaths, sometimes in agreement, sometimes as counterpoints, outside of any narrative logic. The video thus proposes a stylized re-composition of the reality filmed in Venice, to the slow rhythm of the haunting and hypnotic sound modulations of Urban Sax’s music, itself reconstructed. Presented notably in the Video Section of the Cannes Film Festival in 1981, at the 12th Biennale de Paris at the Musée d’art moderne de la Ville de Paris in the fall of 1982 and at the Kitchen in New York that same year, *Urban Sax in Venice* was a great success and widely circulated, emblematic of an artistic appropriation of the Paluche and its formal powers: “A framing that is in a perpetual process of delimitation in which the trembling wavering of the hand finds its place. Caressing with the eyes is no longer a metaphor.<sup>18</sup>”

<sup>14</sup> *Ibid.*

<sup>15</sup> BLANCHET S., “La ‘caméra-œil’ électronique à l’essai. Une interview des frères Blanchet,” *Le Photographe. Le mensuel des professions photo cinéma*, October 1977, p. 114.

<sup>16</sup> Colloque “Métiers et techniques du cinéma et de l’audiovisuel,” *op. cit.*

<sup>17</sup> BLOCH D., “Art-Vidéo français,” 12e Biennale de Paris, 2 October-14 November 1982, Musée d’art moderne de la Ville de Paris, Paris, 1982, p. 51.

<sup>18</sup> DUGUET A.-M., *loc. cit.*

## An Exercise of Reflexivity. *Ciné-portrait of Raymond Depardon* by Jean Rouch and vice versa

| Antony Fiant

On April 19, 1983, around 7 p.m., a few weeks before the theatrical release of *Faits divers*, Raymond Depardon has an appointment with Jean Rouch at the Tuileries garden. He gets there by bicycle, with a photo camera. Rouch is waiting for him, Aaton 16 LTR on his shoulder and rolling, accompanied by operator Philippe Costantini—also equipped with a camera of the same model—and sound engineer Patrick Genet. Very quickly Depardon unveils what seems to be the premeditated aesthetic challenge of the meeting: “The question is to know if our sequence shot will succeed.” And Rouch replied: “Oh! Why not, we’re off to a good start.”

Yet, as we understood even before this exchange, the twelve-minute film will not be the restitution of a sequence shot, but the combination of two sequence shots, the alternating viewpoints of two Aaton cameras on an improvised action and finally reproduced in a breakdown of 28 perfectly matched cut shots (the editing is signed by Marie-Joseph Yoyotte—to whom Rouch had entrusted the editing of *Moi, un noir* and of *La Pyramide humaine*—and Anna Bertona). In a device reminiscent of Mario Ruspoli’s *Method I: exercice de cinéma direct* (1962), Rouch films Depardon’s stroll through the garden while questioning him; Costantini films Rouch filming Depardon. In both cases, Genet, with his tape recorder slung over his shoulder and a boom microphone in his hand, makes vain efforts to stay out of the frame, but the two operators don’t seem to care; Rouch even has fun with it and says: “It’s

beautiful, I’m discovering my little colleagues behind, I love those moments when...”

The discussion begins with *Faits divers*, Depardon’s report to the police, his documentary approach to the world of police stations and other patrols, with allusions to other of his films. But very quickly Depardon decrees that he is not the best person to talk about his films and the film-portrait immediately changes regimen, going from poetic to practical. When Depardon offers to go and see a statue, Rouch does not hesitate, sees no problem with this change of orientation and takes things in hand, placing Depardon on one side of a sculpture by Maillol, a half-extended female nude (*Monument à Cézanne*, 1925), and positions himself on the other side while asking him: “If you photographed her, how would you do it? “If he does take a few shots, however, he does not respond as a photographer but as a filmmaker, not being able to repress an obvious desire to talk about movement. What seems to interest him above all—and this is symptomatic of a conversion from one medium to another that has ►



Légende ?



The combination of two cameras and three operators, not to mention the continuity of direct sound, on a short duration, never ceases to demonstrate the extreme and so very precious adaptability of these tools.

never really been finalized, which is still in its first phase in 1983 (*Faits divers* is never more than his fifth feature-length documentary)—is to film the statue. Rouch then asked Costantini to lend his camera to Depardon for a practical exercise that he willingly carries out with ease, since he is familiar with the handling of Aaton cameras since 1980 and *Reporters*, more particularly the Aaton XTR super 16 mm which he will greatly favor up to *Profilés paysans, le quotidien* (2005), with some infidelities with the Arriflex 35 (on *Délits flagrants* in 1994 in particular)<sup>2</sup>. He frames the feet and slowly—“gently,” he announces—moves upwards towards the head before coming down on one arm.

However, the practical exercise brings him back to the poetic by specifying that on *Faits divers* he tried to avoid unmotivated movements. From then on he delivers a beautiful definition of his own documentary gesture: “In fact, I made myself as small as possible and I didn’t try to pretend to not exist because I don’t think it’s possible. Of course my camera can be seen, I don’t want to disappear, but there are moments when I don’t think it’s necessary to give the impression that the camera is too involved. Sometimes I had to answer actually, I had to answer people who probably asked, ‘What are you doing here?’, ‘What’s this?’ or police officers who were talking to me. I answer, but I don’t believe that you should systematically emphasize the presence of the camera. It must sometimes participate a little of course, but I think it must remain somewhat of an observer with the relativity this can have from an objective camera, I know that it doesn’t exist, so that’s what I saw, that’s what I did.”

Finding and assuming one’s place as a filmmaker, finding and assuming the right distance according to the filmed circumstances (an eminently ethical question in *Faits divers*, particularly in its relationship to death) is a crucial issue for the two

filmmakers, for one of the initiators of direct cinema (Rouch) and one of his heirs (Depardon), for these two followers of films *being made*, with a deliberately uncertain purpose. If the challenges in this film-portrait are of a light and playful nature, without consequence, the reflexivity exercise on which it is based highlights particularly well the preponderant place of technique, in this case the lightweight and handy tools developed by Jean-Pierre Beauviala and the Aaton Company. The combination of two cameras and three operators, not to mention the continuity of direct sound, on a short duration, never ceases to demonstrate the extreme and so very precious adaptability of these tools.

The same goes for the end of the movie. Rouch takes over, improvises the final shot, suggests trying something he claims to always fail at, holding the camera in his hand, at arm’s length, because “sometimes, when it works, it can be sublime.” He then frames the face of the sculpture, catching Depardon in the process, who is still filming and facing him, makes a small correction of the diaphragm and, in the way he concluded *Les Tambours d’avant / Tourou et Bitti* (1972), moves away, filming backwards. And since it is an exercise, in pretending to make a movie, he says to Depardon, taking great care to use the conditional: “I’d leave you face-to-face with your girlfriend.”

<sup>2</sup> Information from the exhibition *Claudine Nougaret: dégager l’écoute. Le son dans le cinéma* by Raymond Depardon, BnF, 14 January - 15 March 2020.

## **ANTONY FIANIANT**

**Antony Fiant is professor of film studies at the University of Rennes 2 where he manages the “Cinema and Audiovisual” master. He works on the aesthetics and dramaturgy of contemporary cinema, whether fiction or documentary, and more particularly on subtractive cinema and the representation of people. He collaborates in several film magazines (Trafic, Positif and Images Documentaires) and is the author of four essays including: Pour un cinéma contemporain soustractif (2014, Presses universitaires de Vincennes) and Wang Bing. Un geste documentaire de notre temps (2019, éditions WARM).**

*Antony Fiant est professeur en études cinématographiques à l'université Rennes 2 où il dirige le master « Cinéma et audiovisuel ». Il travaille sur l'esthétique et la dramaturgie du cinéma contemporain, qu'il soit de fiction ou documentaire, et plus particulièrement sur le cinéma soustractif et la représentation des peuples. Il collabore à plusieurs revues de cinéma (Trafic, Positif et Images Documentaires) et est l'auteur de quatre essais dont : Pour un cinéma contemporain soustractif (2014, Presses universitaires de Vincennes) et Wang Bing. Un geste documentaire de notre temps (2019, éditions WARM).*

## Good-Bye Camera: The 8-35 and the Clouds of *Passion* (Jean-Luc Godard, 1982)

| Vincent Sorrel

The film *Passion* (1982) opens with sublime shots of the sky made without a script, on the fly, capturing the passage of an airplane as the sunlight goes through clouds. They answer perfectly to the filmmaker's desire to fix the emergence of a bright moment before the phenomenon disappears. These shots were filmed with the prototype of a camera, the 8.35, which Jean-Luc Godard had longed for and immediately rejected. The whole film should have been shot with this camera but discordance between the filmmaker and inventor Jean-Pierre Beauviala and the uncertainties of shooting on location put an end to this experience. November 9, 1981, was the first day of shooting for Raoul Coutard. The filming moves outside, on the shores of Lake Geneva for the sequence called "Le Titien." Hugues Ryffel had anticipated the predicted cold—it was almost zero degrees—by sewing a padded jacket for the camera. The next day, when watching the dailies, it was a disaster: the images were streaked, what had been shot with the 8-35 was unusable. It is "general dismay."<sup>1</sup>

In the two interviews published in the *Cahiers du cinéma* in 1983 which go back over the genesis of this camera, the discussion between Jean-Pierre Beauviala and Jean-Luc Godard is short-lived like the fantasy of a dialogue between the industrialist and the filmmaker that this adventure, begun a few years before the shooting of these shots, made

dream of<sup>2</sup>. The filmmaker confided to Jean-Pierre Beauviala that he was looking for the possibility of "being able to make a simple image" or "simply making an image."<sup>3</sup> The camera was ideal to be able to do without technicians but Godard wanted, more broadly, to free himself from the technique:

"Let's see if at some point the technique we're using isn't, perhaps, going too fast. And that indeed a simple technique, like cinema: a small tape recorder and a very simple super 8 camera. There's hardly any need to make synchronous pictures, if you want them from time to time, you've got them. But it's so simple! And it's not true that the world is simple. So all of a sudden, we're going to give a simple picture of it, when we know it's too complex. But we don't have the means! I'm more interested in making simple images and it takes me an hour to make them. So I say, it's not true. There no longer are simple images! There are simple ways to make pictures but there no longer are simple images."<sup>4</sup>

The preparation, the gestures of the technicians, he wants to remove them, like the words, the meaning, to replace them with a camera that allows him to frame himself. So, Godard imagines an ecological camera, that is to say, small enough to take it with him, on the luggage rack of his bicycle, and thus, do without technicians<sup>5</sup>. With this prototype, he wanted an "unclassified object"<sup>6</sup> to make "bits of movies,"<sup>7</sup> i.e. to make a shot without having to set up a production, just like the opening shots of *Passion*.

During the discussion that closes the impossible

<sup>1</sup> RYFFEL Hugues, "Journal d'une caméra qui fait des images...", In *Godard/Machines*, Antoine DE BAECQUE, Gilles MOUËLLIC (dir.), Crisnée, Yellow Now, 2020, p. 72.

<sup>2</sup> "Godard dreamed of this camera," writes Alain Bergala in the introduction to "Genèse d'une caméra. 1er épisode": "We're in Holland, we drive through the countryside, we see a windmill with its wings stopping, we take the camera from the car trunk, we film and we get a 35 mm image, with the best definition available today for both cinema and TV. [...]" "Genèse d'une caméra. 1er épisode", *Cahiers du cinéma*, n° 348-349, June-July 1983, p. 94.

<sup>3</sup> Interview of Jean-Pierre Beauviala with Jean-Luc Godard, August 23, 1974, Aaton Collection, Cinémathèque française.

<sup>4</sup> *Id.*

<sup>5</sup> Godard wanted to keep technicians away because, for him, the profession reduces cinema to a trade, whereas he sees it as an art.

<sup>6</sup> BEAUVIALA, Jean-Pierre et GODARD, Jean-Luc, "Genèse d'une caméra, 2ème épisode", *Cahiers du cinéma*, n° 350, août 1983, p. 56.

<sup>7</sup> *Id.*



dialogue between the filmmaker and the industrialist, he adds: “My idea is for the voice to be the voice of the camera, so to speak, relayed by us, but that we speak the language of the camera and not our own language, applied to a camera.<sup>8</sup>” Godard wanted a camera from before language. To do this, he draws up his own specifications for a camera that would have the simplicity of a Super 8 while filming on the standard 35 mm film stock. He devotes part of the budget of his next three feature films to finance its fabrication. Aaton went to work on it in April 1978. On February 5, 1979, when the prototype was close to being ready, Godard detailed his specifications in a letter to Jean-Pierre Beauviala, published in issue 300 of the *Cahiers du cinéma*<sup>9</sup>: “No bigger than that, the camera, you see [he encloses a picture of the Bell & Howel camera]. We could call it the 8-35 or the 8/35, and you’d put all the refinements of the Aaton 16 in it.”

While the video cameras of the time were still very heavy, Godard uses the image of a small 16 mm reporting camera as a reference for its autonomy. It is a spring loaded camera that can work in any situation but only for about 20 seconds<sup>10</sup>. The prototype meets the specifications: it is lightweight, simple, not bulky, pleasant to hold in the hand or on the shoulder. For Godard, it was precisely a question of not inventing anything: the camera he wanted did not produce any patents (see the text in this issue) since it was more a question of doing without the technical department. The use of the semi-transparent blade instead of a rotating mirror shutter certainly posed problems, but it was a concession to the simplicity of the camera that could be improved upon. Ironically, it is the only sophistication which makes the 8-35 the prototype of the cameras to follow, which

weakened the camera on the shooting of *Passion*. Jean-Pierre Beauviala used his know-how in electronics which had enabled him, at the end of the 1960s, to synchronize two devices, a camera and a tape recorder, to develop a solution which would not be industrialized until many years later: the drive of the claws, the shutter and the film in the magazine is provided by two quartz-synchronized motors, that the effect of the cold on the electronics synchronized, like the dialogue between the filmmaker and the industrialist.

From this story, where technical invention meets ►

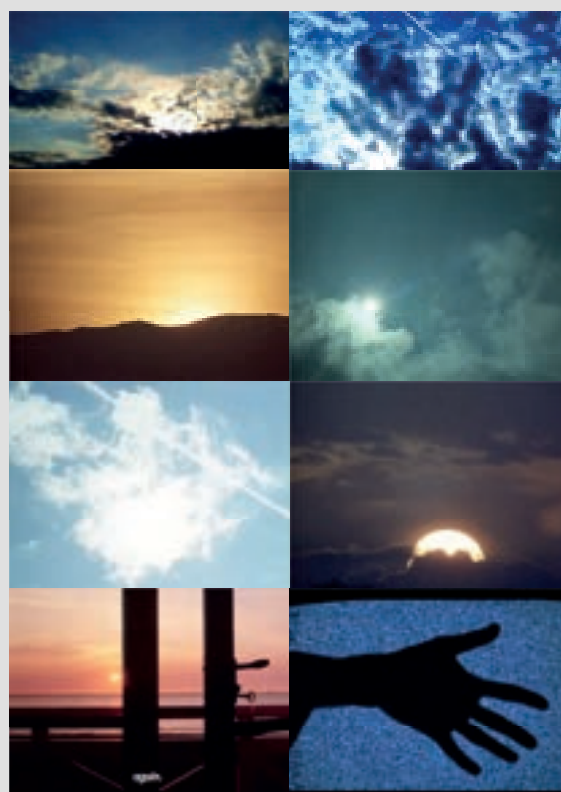

Fig. 1 : The skies Godard

<sup>8</sup> *Ibid.*, p. 52. <sup>9</sup> *Cahiers du cinéma*, spécial Godard, 1990, p. 28-29.

<sup>10</sup> The autonomy of the camera, designed in the 1930s, is 3 minutes of film but the spring time limits the shooting to about 20 seconds. It is the camera that was used, in the years 1940-1950, by Jean Rouch, whose films fascinated Jean-Luc Godard. One can recognize a Bell & Howel Eyemo, used by a journalist, in the the press conference sequence of *A bout de souffle* (1959).



formal invention, we are left with these few shots of *Passion* but also with the filmmaker's obsession with clouds<sup>11</sup>. A few years later, in *Soft and Hard*, Godard reuses shots of skies and clouds which are very close to the ones in *Passion*. They appear superimposed on a sequence that features the filmmaker and Anne-Marie Miéville in a car. Miéville goes out for a walk, Godard says: "Oh yeah, but I have to be at peace with the world to go out. We find shots of clouds, in reference to those shot with the 8.35, in almost every movie, throughout Godard's work, until *Adieu au langage* (2014). *Sauve qui peut (la vie)*, a few years before *Passion*, already opened with shots of clouds. There are many in *Je vous salue Marie* (1985) that are shot at different times of the day like close-ups of the sun and moon. In *Prénom Carmen* (1983) and *Film Socialisme* (2010), it is the pattern of the waves that replace them while a sentence in the film's dialogues questions their power: "And the clouds. Do the clouds show streams of life?"<sup>12</sup> In *Soigne ta droite* (1987), we are literally in the sky with several scenes shot in a commercial airliner, including one in the cockpit. In *King Lear* (1987), the sky is this time filmed at the end of the day in a shot wide enough to see the trees. With this sequence, the premise of repetition and variation also shifts to the sound side, since we hear the sound of a helicopter and "the long, haunting cries of birds tearing through the soundtracks of all his movies since *Prénom Carmen*."

With these shots that correspond to documentary type shootings inside his fictions, Godard is not looking for coincidences. These nature shots are there to intersect the stories, because if there was too much story, the viewer would not be looking at anything else. In 2019, he continues to use the metaphor of clouds to talk about the relationship

between images and language, focusing on what we do not see, the substance of things, on what is already there: "Language is what will be behind, like the clouds in Delacroix's watercolors. That's what Baudelaire says in *L'Étranger*: "I love the clouds, the wonderful clouds."<sup>13</sup> Through this gesture, it is not realism that interests Godard but the desire to see so that the spectator in turn can experiment with his own way of looking. He says so in *Scénario du film Passion*: "What I'm trying to show you is how I see, so that you can then judge if I am able to see and what I have seen."<sup>14</sup> About *Passion* and his quest for the camera, he says: "Afterwards, I tried to see, to move forward only by seeing. We almost brought the film to physical and financial ruin by wanting to see [...] The scene we had to shoot is behind the cloud, the cloud had to go away to see it. And the cloud, it's what's in the way we function, in our thoughts."<sup>15</sup> Godard contrasts language with seeing: "We must see things, we must not talk about what we have seen, we must see and stay in the seeing."<sup>16</sup> You just have to look and then "the smallest creation becomes a miracle," as we hear in the dialogues of *Soigne ta droite*<sup>17</sup>.

<sup>11</sup> In parallel to the shots of clouds transperced by the sun, Godard multiplied shots of bad weather on a car windshield, with rain or snow making it impossible to see. To read, on this subject: Vincent Sorrel, "S'endormir tout contre la caméra et rêver," In Vincent Deville and Rodophe Olcèse (dir.), *L'art tout contre la machine*, Paris, Hermann, to be published in 2021.

<sup>12</sup> GODARD Jean-Luc, *Prénom Carmen*, 1983.

<sup>13</sup> DELORME Stéphane and LEPASTIER Joachim, "Ardent espoir. Entretien avec Jean-Luc Godard," *Cahiers du cinéma*, n° 759, October 2019, p. 8.

<sup>14</sup> GODARD Jean-Luc, *Scénario du film Passion* (1983).

<sup>15</sup> GODARD Jean-Luc, *Jean-Luc Godard par Jean-Luc Godard* (1985), edition established by Alain Bergala, volume 1 (1950-1984), Paris, Cahiers du cinéma, 1998, p. 499.

<sup>16</sup> *Ibid.*, p. 463.

<sup>17</sup> GODARD Jean-Luc, *Soigne ta droite* (1987).

## The Aaton XTR on the Set of *Route One/USA* (Robert Kramer, 1989)

| Simon Daniellou

Equipped with an Aaton XTR Super 16 synchronized with a Nagra IV stereo recorder, Robert Kramer, Richard Copans and Olivier Schwob traveled between September 1987 and March 1988 along the East Coast of the United States of America along Route 1, which gave its title to the film *Route One/USA* completed one year later. Manufactured from 1984 onwards, the camera reuses the Aaton 7 LTR “cat on the shoulder” silhouette, designed to fit the shape of the human body and to free the user’s view. In between the two models, the clear time marking, an electronic device that inscribes eye-readable time markers on the film while shooting, has been redesigned in the form of a matrix code, the AatonCode, which was now suited to the new video editing machines. This modification was accompanied by another accessory, the Aaton Origin C master clock, which allowed the various Aaton cameras, thanks to a quartz crystal, to be synchronized with most sound recorders on the market at the time. This removal of the cable, until then essential in order to give the tape recorder a signal with a frequency proportional to the speed of the camera’s motor in order to ensure their synchronization at the time of transferring the smooth magnetic tape to the perforated optical tape, therefore allowed for the separation of sound and image recording, in addition to avoiding the use of the clapper when changing the view angle<sup>1</sup>.

Cat on the shoulder, but from now on a cat whose senses of sight and hearing are alert to different

stimuli, the XTR camera will participate in Robert Kramer’s looking at and listening to these United States of which he is trying, after a prolonged absence, to put the pieces back together at the end of the Reagan era. On his way through New Hampshire, he comes across the campaign of an ultra-conservative televangelist, Pat Robertson, a candidate for the 1988 U.S. presidential nomination. During a 6-minute sequence at the 45<sup>th</sup> minute of the film, Kramer and his fellows mingle with the little hands busy at the candidate’s side that another film crew, for television this time, also follows with traditional equipment that requires a promiscuity of the image and sound operators, while a supporter videotapes Robertson’s statements from a unique listening point and point of view. In contrast to the aesthetics induced by this equipment, Kramer’s approach to filming will consist in analyzing through breaking down, and then recomposing during editing a network of relationships invisible at first glance.

The independence between the image and sound recorders allows for a different approach to the visual and sound space, the Aaton equipment greatly influences the directing choices. Faced with these United States that he rediscovers and shows us in his own way, Kramer can in fact sometimes opt for a virtual shot breakdown through a panoramic shot, which the “cat on the shoulder” encourages, or for a real shot breakdown via a relay character whose immersion in this world he can apprehend without sticking to it, thanks to the fact that the umbilical cord between camera and recorder has been cut. The character of Doc, played by Paul Mclsaac, inspires the project of this movie which blends documentary and fiction and serves as an intermediary for the filmmaker ►

<sup>1</sup> During the shoot, Kramer must nevertheless film reel number or film sensitivity indications, while in post-production, a reprint of a coding via a printer called “Adage” onto the image and sound tapes is eventually necessary in order to allow the naked eye to locate the audio track transferred to 16 mm tape during viewing on the editing table.



**traduction ?** Robert Kramer et Richard Copans sur le tournage de *Route One/USA*, en couverture d'une revue fictive pastichant les *Cahiers du cinéma* à des fins publicitaires. Fonds Aaton / La Cinémathèque française

as he approaches the members of the different communities he met a few days before the arrival of the rest of the film crew. In this sequence, as in many others, Kramer uses shots of the Doc observing his fellow citizens as anchors to structure his editing, which he anticipates during shooting by making real shot breakdowns, i.e. by opting for viewing angles that are not aimed at the main object at the center of everyone's attention. Thanks to the constant synchronization of image and sound despite the physical disassociation of the cameras, Kramer can afford to film somewhere else than where Schwob, who stayed with Doc,

is located, and then join them if something interesting happens on their side.

On several occasions, however, Kramer can do without the Doc and can exchange with individuals who approach him thanks to the openness to others that the Aaton XTR offers, by keeping his face unobstructed and not requiring the presence of a large crew at his side. As the filming progresses, the Kramer-Doc relationship seems to take a back seat and several strong scenes in the movie are based directly on the relationship that the filmmaker, behind the camera, has with those he is filming. The sequence with Robertson's followers illustrates how Kramer shows real empathy for everyone during the shooting, before highlighting significant details through editing, such as the breaking of the ribbon that serves as his cutting point, or the fleeting misunderstanding during a handshake the politician gives to one of his followers while ignoring his wife. For while the shaken hands, the distribution of leaflets, the thoughtful songs and lyrics testify to the solidarity of the community, this sincerity does not manage to conceal the falsehood of the candidate that the filmmaker—whose point of view is, thanks to the Aaton equipment, no longer subject to the power of speech—can come to unearth in the blunders and unconscious mistakes of his compatriots.

## Filming the Emergence of Speech: *Entre les murs* (Laurent Cantet, 2008)<sup>1</sup>

| Gilles Mouëllic

Laurent Cantet's intention for *Entre les murs* (2008) is to record a musicality specific to adolescent language and phrasing, while managing to capture the energy and tension of a collective voice, a voice that can emerge without warning depending on the reactions of one of the twenty-four actors who make up the middle school class. It therefore needs an extremely flexible recording device in order to show and hear the mobility of this voice. This recording is conditioned by the performance of digital technologies with which sound and images have gained in agility and, as far as sound is concerned, in quality and reliability. Firstly, for the images, three shoulder-mounted Panasonic VariCam HD cameras are constantly filming, one the teacher, the second the students who are supposed to intervene in the scene, and the third the students for unexpected speech. Cantet has in front of him on a screen separated in a split screen the return of each of these cameras and can give indications to the cameramen at any time. The sounds are captured on two Cantar multitrack digital recorders. One takes the two booms, HF microphones and the mixdown, i.e. the reduction of the whole set on two tracks thanks to a mix made in situ by the sound engineer, the second records a stereo pair, the microphones positioned on the ceiling and possible additional HF. In total, there are therefore sixteen audio tracks recorded simultaneously, and three cameras that will eventually total one hundred and forty hours of rushes for two hours of movie<sup>2</sup>.



Laurent Cantet in front of the return monitors of the three cameras.

This device allows for a remarkable reactivity throughout a shooting presented by Cantet as follows: "The camera's moving because one of the instructions we gave ourselves was to try not to lose anything. For the sound is even more obvious. [...] There was the desire not to presuppose something that was going to happen but to be ready to make it resonate in the film. There was a desire for that kind of mobility and then the desire to respect the rhythm of the scenes for the actors, that is to say, to give them the possibility to play for twenty-three minutes a scene that we knew in the end would only last five. But they are in a rhythm, in a reality of the situation that makes it preferable to do the first one or two takes in this continuity. So we needed to be able to move camera very quickly<sup>3</sup>. Here Cantet reiterates the length of time necessary both for the inclusion of free speech and for the existence of true improvisation. This device will allow for the invention of a shooting method that renews the relationship between the director and his actors, while recalling some of Jean-Luc Godard's experiences whispering the dialogues during the take. Multi-camera►

<sup>1</sup> This text is a partially revisited excerpt from "*Entre les murs* (Laurent Cantet, 2008), un dispositif numérique d'enregistrement," published in Antony FIANI, Roxane HAMERY and Jean-Baptiste MASSUET (eds.), *Point de vue et point d'écoute au cinéma : approches techniques*, PUR, coll. Le Spectaculaire/ Cinéma, 2017, p. 175-184.

<sup>2</sup> These technical specs are taken from the very valuable booklet entitled *Cantet/Campillo: en monter entre les murs*, produced by the members of the association *Les monteurs associés* from one of their annual meetings. This is an exchange that took place on October 7, 2009. This booklet is not publicly available.

<sup>3</sup> *Cantet/Campillo : en montant Entre les murs*, op. cit., p. 20.

filming with a sound system capable of capturing in excellent conditions all the students' interventions allows Cantet to interrupt a take to react to an event or to redirect a sequence without suspending the recordings. It is therefore never a question of conforming to prior choices stemming from a precise scenario, but of collectively managing, thanks to a continuous collective commitment, to reinvent each of the scenes during the shooting, which Cantet sums up with this beautiful formula: "the take becomes a rough draft of itself to a certain extent."<sup>4</sup> It is the technical comfort of the device that allows all the participants to react, each one being able to be totally focused on the present. This desire not to ritualize the director's interventions desacralizes the recording and releases new energies based on permanent exchanges between the film crew and the actors, exchanges that establish a form of pleasure of acting that we find throughout the film. The technical means used also have the consequence of radicalizing practices already tried and tested by other improvising directors. It is the case, for example, and to stick to speech, of shooting sequences in the order of the script in order to involve the actors in the long-term rhythm of dramaturgy; it is also the case of what I have elsewhere called the "direction from within."<sup>5</sup> Bégaudeau, who is responsible for part of the direction during the shooting, has a great deal of freedom of action and can change the trajectory of a sequence or exploit an unexpected intervention by one of the characters. But Cantet also asks, individually, actors to speak after certain lines in order to trigger possible reactions from fellow actors. These different methods show once again how improvisation in cinema is based on finding a balance between the mastery of a complex system, the rigidity of trajectories and the introduction of moments of freedom.

The mass of recorded information naturally requires an

enormous amount of work going through the rushes, which largely consists for Cantet in choosing the most relevant sound tracks according to the images, but which also includes a great deal of surprise in front of replicas discovered on this or that track which will have to "find their images" if need be. The assistant editor, Stéphanie Léger, has been charged, sequence after sequence, to explore these different sound tracks so as to identify the improvised responses likely to enrich the exchanges. The technical system therefore makes it possible to have a very large quantity of material in your possession, a material that is enriched in this case by the fact that every sequence has been lengthily worked on, guaranteeing they really follow a common path.

Working every Wednesday for a whole year with all the students who have become actors for the film, Cantet uses theater to manage to give form to his film project, but it is thanks to digital technologies that he will be able to invent a new way of combining the two means of expression. The recording device makes it possible to go from the work in progress of the workshop to the performance of the shooting without sacralizing the moment of the take, by continuing to put each scene into question. *Entre les murs* keeps the traces of this fragility, of this desire not to fix anything by repetition: "[...] What we try to obtain, to capture in a film, is what the actor does only once, it is what happens only once."<sup>6</sup> This ideal laid out by Jacques Rivette after the shooting of *L'Amour fou* (1969) finds a form of accomplishment in *Entre les murs* where, exceptionally, a fiction movie based on the verb manages to sustain the inimitable vigor of the emergence of speech during two hours.

<sup>4</sup> Personal interview conducted in Paris in June 2013, unpublished.

<sup>5</sup> *Improviser le cinéma*, Crisnée, Yellow Now, 2011, Chapter VI, p. 136-162.

<sup>6</sup> COHN Bernard, "Entretien sur l' 'amour fou,' avec Jacques Rivette," *Positif*, n° 104, April 1969, p. 36.

## ***The Hurt Locker* (Kathryn Bigelow, 2008) and the A-Minima Camera**

| Jean-Baptiste Massuet

*The Hurt Locker* made a lot of headlines at the time of its release in 2009 by its will to be in touch with a reality as harsh as it is disturbing via a direction inherited from war documentary aesthetics. The edgy style Kathryn Bigelow adopted here is largely based on the choice of two camera models from the Aaton workshops: the Aaton XTR and the A-Minima, sold at the time of its release as “the world’s smallest Super 16 HD Camcorder.”<sup>1</sup> The film is particularly noteworthy for the technical system set up by its director, based on the question of the look: the XTR cameras frame the action, and in particular, they show the point of view of the snipers who monitor the bomb disposal experts in charge of securing the booby-trapped areas. But if the phenomenon of immersion proposed by *The Hurt Locker* seems to be based on playing with the surveillance and the tension inherent to it, the use of the A-Minima camera also opens up another immersive perspective, linked to the question of physical presence: Barry Ackroyd, the chief operator of the movie, was indeed able to insist on his role as a cameraman on the set, placing himself with the A-Minima at the heart of the action and not in the background or as an observer like the other operators with their XTR cameras.

But when he is asked about the most challenging moments of the shoot, Barry Ackroyd, rather than referring to the triangulation of the action by the XTR cameramen, often cites “the scene inside the car [...]. Jeremy [Renner] and I were inside [...] struggling to frame. It’s a scene I really like, but it was hard to shoot. You can see the sweat dripping off Jeremy.”<sup>2</sup>

The sequence, which takes place in the first half of the movie, reveals the main character struggling with a bomb whose hidden detonator he tries to find in the body of a car, while being under threat of snipers. We suggest to see in this comment a reflection on the immersiveness allowed by a camera like the A-Minima, aiming to transcribe and share the way the character lives and experiences his job as a mine-clearing expert, without distance, constantly caught in the urgency of the situations he faces.

In contrast to the use of XTR cameras, which are based on questions of distance, the A-Minima model introduces a closeness to the body, replaying the character’s physical commitment (a direct confrontation with trapped objects) through the physical commitment of the cameraman alongside the actor. An intimate relationship is established as



***The Hurt Locker*'s team with the Aaton XTR, the A-Minima, and the Cantar on the sound cart.**

a consequence of the small size of the camera that allows it to be extremely close to the actor, even in a very small space, without interfering with his ▶

<sup>1</sup> MANNONI Laurent, “Camera film super 16 mm (CNC-AP-13-1128),” Catalog of the cinematographic devices of the cinémathèque française and the CNC, undated, available at: <http://www.cinematheque.fr/fr/catalogues/appareils/collection/camera-film-super-16-mm-cnc-ap-13-1128.html> (last consultation on 22/02/2020).

<sup>2</sup> POND Steve, “Hurt Locker’s Moments of Truth with Barry Ackroyd,” Interview with Barry Ackroyd, *The Wrap*, February 19, 2010. Available at: <https://www.thewrap.com/hurt-lockers-moments-truth-barry-ackroyd-14438/> (last consultation on 22/02/2020).

<sup>3</sup> BEAUVIALA Jean-Pierre, In *L’œil mécanique*, Laurent Lutaud, 1995, 4 mn 27.





**Free of the superfluous, the two men, Renner and Ackroyd, keep to the essentials: a pair of bolt cutters for the first, a tiny camera for the other, allowing them both to be physically present inside the car's carcass.**

actions. This contextualization of the cameraman's body can be felt in that sequence, first when the car burns, Ackroyd closely follows Renner as he tries to extinguish the fire with his fire extinguisher. The A-Minima follows the path of the fire extinguisher, from the soldiers who bring it to the character who uses in the middle of the flames, in medium and close-up shots: framings that transcribe the urgency of the situation but also its physical aspect, devoid of any distance.

In this sense, Jean-Pierre Beauviala's intended use of this camera—a camera “no longer of shoulder, but of act, guided by the head<sup>3</sup>”—is fully embodied here, by this reduction of distance (both physical and symbolic) between the cameraman and the actor, as if both shared the same body. Dziga Vertov's quote that opens the documentary *L'Oeil mécanique* on the A-Minima informs us about the ideal conveyed by the device: “From now on I will be free from human immobility. I am in constant motion, I approach things, I move away from them, I enter them, [...] I go through the crowds at full speed, I precede the soldiers in the assault, [...] I tip over on my back, I fall and get up again at the same time as the bodies fall and overturn. This is how I decipher, in a new way, the world that is unknown to you.<sup>4</sup>” The choice of the A-Minima, in that perspective, seems to be quite different from the use of XTRs that Bigelow used in her movie, as if to oppose two ways of thinking immersion, yet always in phase with the characters portrayed. The action of the character played by Jeremy Renner does not take place through his vision, but through his physical involvement.

The most significant sequence in that respect is

undoubtedly when Jeremy Renner enters the car to find the detonator of the bomb he discovered in the trunk. Before making his way into the vehicle, the character gets rid of his cumbersome suit with this formula: “If I have to die, then I might as well die comfortable.” Undoubtedly, the character's dis-equipment seems to echo that of the cameraman equipped with the A-Minima, free from the heaviness of an overbearing setup, which could consist of an obstacle between the cameraman and what he portrays. Free of the superfluous, the two men, Renner and Ackroyd, keep to the essentials: a pair of bolt cutters for the first, a tiny camera for the other, allowing them both to be physically present inside the car's carcass. The shots are tighter than the sequences filmed with the XTRs, precisely dissecting the character's *modus operandi*, placing us on an equal footing with him. In the same way as with the snipers, Ackroyd, through his conception of the frame, involves us directly alongside the characters by adapting his direction to the challenges related to their profession.

The Aaton operators could thus be seen and interpreted as almost full-fledged team members, or even as direct incarnations of the characters, imitating their actions (the XTRs watching the surroundings, the A-Minima taking apart each piece of leather or plastic of the car to look for what is hidden inside). For Kathryn Bigelow, it was a question of transcribing “the way in which we actually perceive reality, by looking at both the microcosm and the macrocosm simultaneously. The eye perceives differently than with the lens, but with multiple

<sup>4</sup> VERTOV Dziga, “Manifeste du Ciné-Œil,” 1923.

<sup>5</sup> BIGELOW Kathryn, quoted by Nick Dager, “Shooting The Hurt Locker,” *Digital Cinema Report*, 2 December 2010, available on the URL: <https://www.digitalcinemareport.com/article/shooting-hurt-locker#.XID4dDBKiUrm> (last consultation on 22/02/2020)



focal lengths and a muscular editing style, the lens can give you that micro/macro perspective, and that contributes to this complete immersion feeling.<sup>5</sup>” As we once again see, this notion of immersion is at the heart of the filmmaker’s reasoning. Far from stylistic coquetry, the use of the A-Minima (as much as of the XTR cameras) tells us something about the role of technologies in the immersion process, and makes us understand that the size or weight of a camera can determine different ways of apprehending the world, and of sharing it with the spectators.

*The Hurt Locker* constitutes undoubtedly, in that respect, an important object to examine the imagery of immersion in the 2000s, as well as the lightweight cameras that have contributed to determining its aesthetics.

## The Performances of the Cantar Put to the Test in a Sequence of *Holy Motors* (Leos Carax, 2012)

I Gilles Mouëllic

For many sound engineers, Aaton's introduction of the Cantar multi-track digital recorder in October 2003 was a major event in the history of live sound recording. Born out of a close collaboration between Jean-Pierre Beauviala and film professionals, the Cantar has made it possible to record direct sound of remarkable quality in difficult, even extreme conditions<sup>1</sup>. Among the cinematic moments whose existence largely depend on the performance of this device, the fanfare sequence filmed in the Sainte-Merri church for Leos Carax's film *Holy Motors* (2012) is a canonical example, because of the challenge it represented for sound engineer Erwan Kerzanet, trained in the sound department of the Ecole nationale supérieure Louis Lumière (year 1997). Him and his team needed a technical response to the direction choice made by Carax, who wanted to film an ensemble of about fifteen musicians moving through a church. The sequence is an interlude, a pure moment of musical performance, with an important number of accordions played by several generations of musicians. As in the rest of the film, Carax favors direct sound, and the most obvious solution—post-synchronization in the studio—is therefore discarded despite the difficulties of recording in situ. Because the musicians will be encouraged to move around, Kerzanet also refuses to install a fixed and complex recording system designed to turn the church into a real recording studio:

"I had to stay within the logic of a movie shot," he explains in an interview with *Cahiers du cinéma*, "not of a digital sound take. So I switched all my sound recording equipment to a mobile configuration so I could be at the level of the accordion and follow the band. I used an experiment I'd carried out on a short film by Pascal Rambert, where the scenes were to be played in direct sound in the middle of the electro music of a nightclub. I cascaded recorders to gather the musicians' sound in multi-track while recovering the sound of the 'cinema shot' on my machine. A track for all the accordions, a track for the drums and a track for the guitars and the bass, the maracas and the harmonica. In that way it was possible to start to play with the instruments right from the editing table. For each of the eleven takes, we were three sound engineers moving around the church around the accordionists, each with an eight-track Aaton Cantar recorder on the shoulder, plus a four-track Sonosax on the drums, also mobile. Twenty-three HF microphones in total."<sup>2</sup>

The performance, portability and mixing possibilities of the Cantar, combined with the miniaturization and quality of the HF microphones, are all elements that explain how Erwan Kerzanet was able to choose mobility by physically accompanying the musicians' movement in space in order to remain within the "logic of the cinema shot." He thus responds to the two-minute sequence-shot in which the camera precedes Denis Lavant alone, and then the entire orchestra, whose members gradually enter the frame, joining the collective movement. This live capture of the movements of the sound is a means of being within the very substance of the sound, with the movements of the bodies, whereas post-synchronization would have generated a distance

<sup>1</sup> See the texts of Camille Pierre in this same issue.

<sup>2</sup> "Les onze nuits d'un rêveur," Interview with Caroline Champetier and Erwan Kerzanet, *Cahiers du cinéma*, n° 680, July-August 2012, p. 90.

with this materiality and vitality which are part of the staging. The accordion is an instrument which finds its full expression in a confrontation with the body of the instrumentalist through singular gestures whose amplitudes are accentuated by the very expressive way the musicians play. The density of this choreography of gestures is based on the live recording of a polyphony specific to fanfare music, which carries something of the history of cinema as a recording of moving bodies engaged in a common trajectory, from Julien Duvivier of *La Belle Équipe* (1936), when an accordion tune is enough to evoke the collective utopia of the front populaire, to Miguel Gomes of *Ce cher mois d'août* (2008) who, to give new energy to this same utopia, opens his movie with a long sequence punctuated by the wandering of a brass band through the streets of a small Portuguese town. In the *Holy Motors* sequence, the sophisticated combination of music that seems to have stood the test of time with the most contemporary digital technology makes it possible to capture the immediacy of a seemingly simple sound event. The expressiveness of the shot is based on the evidence, the energy and the photogeny of this polyphony of bodies and on the movement of walking: the collective mobile recording device responds to the mobility of the music.

The Cantar and other generations of portable multi-track digital recorders are driving a renewal of diversity and quality of live sound. Recording the heterogeneity of sound material is the source of new possibilities for mixing and inventing new sound universes, as sound creation can be based on the sophistication and richness of live performances. The Cantar's performances mark another stage in the history of recording linked to direct cinema while brilliantly materializing Jean-Pierre Beauviala's interest in sound, he who had the elegance to wait for the withdrawal

from professional life of Stephen Kudelski, the inventor of the Nagra, to create his own multitrack digital sound recorder. That sound engineers consider the arrival of the Cantar as a real revolution signals both Beauviala's genius and his perseverance: the device is the tangible result of a long quest that began in the sixties with a film project on his city of Grenoble, where he had observed in the field both the potential expressiveness of the articulations between images and sounds and the technical limits of their implementation.

## Aaton Cameras on the Set of *First Man* (Damien Chazelle, 2018)

| Simon Daniellou

*First Man: The First Man on the Moon* portrays an obsessive Neil Armstrong whose engineering temperament nourishes his attempts to control a life with unpredictable accents over the course of a decade that saw him succeed in his unprecedented journey despite a string of dramas: from his entry into NASA's Gemini program the day after the death of his daughter, to his first step on the Moon's surface on July 21, 1969. Thus presented, he is part of a gallery of diehard characters who seem to particularly attract Damien Chazelle, after the young drummer from *Whiplash* (2014) and the jazzman from *La La Land* (2016). Familiarized with the A-minima camera during the shooting of a sequence of the latter, the filmmaker told his cinematographer Linus Sandgren early on during the preparation of *First Man* that he wanted to shoot with Aaton cameras. The crew managed to convince Universal Studios that this Super 16 equipment constituted "the soul of the cinematography of this film:" "I felt that the Aaton A-Minima and the XTR, that 'man camera' feeling, were a perfect match for what we wanted to convey at the heart of the movie, [...] to go towards an intimacy and realism that we found difficult to achieve when shooting in conventional 35 mm," Sandgren says. But beyond a "cinéma-vérité" aesthetic<sup>1</sup> that is finally quite common in a certain fringes of contemporary American cinema—with its wide-angle and close-up camera sequences of actors improvising "slices of life," evoking Terrence Malick's latest movies—, The choice of this relatively singular material in a studio production particularly matched Chazelle's very personal psychological portrait of the

main character, as if he was trying to break his image of "Mister Cool," as his colleagues nicknamed him.

Similar to the painter's range of brushes, the Aaton cameras will thus adapt to the subject and especially to his path, that of a pilot-engineer seeking at all costs to master a reality which escapes him, that the NASA "stabilizer" exercise symbolizes at the beginning of the space program, the impossibility to control it leading the "guinea pigs" who dare harness themselves in it to pass out. Family scenes, often tense, are shot with an Xterà camera whose Super 16 grain vibrates under the pressure of daily life, both the pressure that Armstrong's risky job exerts on his couple—"What I wanted was stability," his wife says about their marriage—but also the pressure that life's ups and downs imply on the aerospace engineer's path. For his constant attempts at rationalization are as much at odds with his daughter's illness (the symptoms reported in detail in ultimately useless notebooks) as with the spontaneity of his two boys (the risks coldly reduced to statistics too abstract for them), not to mention the fatal accidents that punctuate the American space program. Each time a death is announced, the filmmaker and his cinematographer play on the very narrow sharpness of an image filmed with a zoom during close-ups on the face of the protagonist, balanced on the swing of an uncontrollable reality. In the sequences around the space program, the 35 mm 2-punched Aaton Penelope—a camera whose "foreground intimacy/background vibrancy ratio is more in line with the dynamic vision of the human eye,"<sup>2</sup> according to its inventor—participates in the establishment of a character who finds himself in his element, while still recollecting the human work behind each technical achievement. The silver grain also underlines the rusticity of the equipment used

<sup>1</sup>

"The director of photography Linus Sandgren, FSF, talks about his work on '*First Man*' by Damien Chazelle", AFC, online 13.11.18, last consulted on 04.09.20 [https://www.afcinema.com/Le-directeur-de-la-photographie-Linus-Sandgren-FSF-parle-de-son-travail-sur-First-Man-de-Damien-Chazelle.html].

<sup>2</sup>

In French in the text, Chazelle and his editor notably summoning *Crisis* (1963) by Robert Drew in the audio commentary of the film (Blu-ray Universal Pictures, 2018). The following quotations are also taken from this commentary. Sandgren, for his part, uses the same expression but in relation to a reference such as *The Battle of Algiers* (Gillo Pontecorvo, 1966). Cf. "Rocket Science. Linus Sandgren FSF/First Man," British Cinematographer, last accessed 04.09.20 [https://britishcinematographer.co.uk/linus-sandgren-fsf-first-man/].

by NASA, which is never safe from the unforeseen, whether it is a plastic ball blocking the buckle of a belt, an untimely alarm on the approach of the lunar surface, or a fly that managed to get into the cabin of the Gemini 8 capsule<sup>4</sup>.

In order to escape uncertainty, the astronaut focuses on his mission, his eyes constantly riveted on the Moon, assuming the danger of test flights that must serve to avoid the worst on D-day, breaking the lyrical questions of journalists with prosaic answers, calling to order a colleague who talks too much



On the set of *First Man* de Damien Chazelle

under the effect of nervous tension. The smallness of the A-minima camera nevertheless allows Chazelle to re-inject humans into the machine, with Linus Sandgren himself entering the Gemini 8 capsule from a subjective point of view, when mental flashes in Super 16 do not interfere with the high

definition images of lunar exploration. A heart beats under Armstrong's spacesuit, and the filmmaker emphasizes the contrast with the temperament of his co-pilot Buzz Aldrin, a "hopeless" realist who "tells it like it is" and thus secures a place in the Apollo 11 mission, at the risk of getting reprimanded by his colleagues. Through the use of such filming equipment at a time when digital clinical imaging dominates big budget movie productions<sup>5</sup>, Chazelle infuses his story with the sensitive intelligence of another engineer, a singular inventor from Grenoble who has relentlessly sought to adapt his equipment to the uncertainty of reality. Once the two astronauts have landed on the Moon, one might fear a form of renunciation when from the Super 16 in hand-held mode—chosen as granular as possible according to Chazelle—we switch to IMAX on Steadicam, in a transition evoking, according to the editor's own words, the switch to Technicolor in *The Wizard of Oz* (V. Fleming, 1939). Where Jean-Pierre Beauviala went so far as to try to reproduce the swarming of the grain on a digital medium with the Delta Penelope, the film crew opted for the very high definition of the 65 mm. But it is precisely to show another grain, the one of the dust covering the lunar ground, in an environment that no longer has anything human, Chazelle not playing in this *final* the card of the spectacular but the one of emptiness. Because *First Man* tells first and foremost the story of the Armstrong couple, whose silent reunion, which happens through touching, is finally collected under the benevolent eye of an Aaton camera.

<sup>3</sup> Comments by Jean-Pierre Beauviala, *Cahiers du cinéma*, no 638, October 2008, p. 11.

<sup>4</sup> Detail irresistibly reminiscent of the argument of the film *The Fly* (The Fly, D. Cronenberg, 1986).

<sup>5</sup> Gestures reiterated in *The Eddy* (2020), Netflix series that he co-produced and whose first two episodes he directed with an XTRprod.

## Bibliographie

### Analog/Digital Transition

- > “Adieu 35 – La révolution numérique est terminée,” *Cahiers du Cinéma*, n° 672, November 2011.
- > “De l’iPhone à l’Imax – Dossier spécial caméras,” *Cahiers du Cinéma*, n° 719, February 2016.
- > ALFONSI Laurence, *Le cinéma du futur: les enjeux des nouvelles technologies de l’image*, Paris, L’Harmattan, 2005.
- > BEAU Frank, DUBOIS Philippe and LEBLANC Gérard, *Cinéma et dernières technologies*, Paris & Bruxelles, De Boeck, 1998.
- > BOLTER Jay David, “Transference and Transparency: Digital Technology and the Remediation of Cinema,” *Intermédialités*, n° 20, 2012, p. 171-184.
- > BOZAK Nadia, *The Cinematic Footprint. Lights, Camera, Natural Ressources*, New Brunswick, Rutgers University Press, 2012.
- > CARTWRIGHT Lisa, “Film and the Digital in Visual Studies: Film Studies in the Era of Convergence,” In Nicholas MIRZOEFF (dir.), *The Visual Culture Reader*, London, Routledge, 2002, p. 417-432.
- > CHERCHI USAI Paolo, *The Death of Cinema: History, Cultural Memory and the Digital Age*, London, British Film Institute, 2001.
- > CHUN Wendy Hui Kyong and KEENAN Thomas (eds.), *New Media / Old Media. A History and Theory Reader*, New York & London, Routledge, 2006.
- > COMOLLI Jean-Louis and SOREL Vincent, *Cinéma mode d’emploi. De l’argentique au numérique*, Lagrasse, Verdier, 2015.
- > CUBITT Sean, *The Practice of Light. A Genealogy of Visual Technologies from Prints to Pixels*, Cambridge, MIT Press, 2014.
- > CUBITT Sean, *The Cinema Effect*, Cambridge, MIT Press, 2004.
- > DELBRIDGE Matt, *Motion Capture in Performance. An Introduction*, Basingstoke, Palgrave Macmillan, 2015.
- > DIODATO Roberto, *Esthétique du virtuel*, Paris, Vrin, 2011.
- > DRUCKREY Timothy (dir.), *Electronic Culture: Technology and Visual Representation*, New York, Aperture, 1996.
- > ELSAESSER Thomas and HAGENER Malte, *Film Theory. An Introduction through the senses*, New York & Oxon, Routledge, 2015.
- > ELSAESSER Thomas and HOFFMANN Kay (dir.), *Cinema Futures: Cain, Abel or Cable? The Screen Arts in the Digital Age*, Amsterdam, Amsterdam University Press, 1998.
- > ENTICKNAP Leo, *Moving Image Technology. From Zoetrope to Digital*, London, Wallflower Press, 2005.
- > FINK, Edward J., “The impact of digital video technology on production: the case of American gothic,” *Journal of Film and Video*, vol. 48, n° 4, Winter 1997, p. 9-19.
- > FOSSATTI, Giovanna, *From Grain to Pixel. The Archival Life of Film in Transition*. Amsterdam, Amsterdam UP, 2009.
- > GANZ Adam, and KHATIB Lina, “Digital Cinema: The Transformation of Film Practice and Aesthetics,” *New Cinemas: Journal of Contemporary Film*, vol. 4, n° 1, 2006, p. 21-36.
- > GAUDREAUULT André, and MARION Philippe, *La fin du cinéma? Un média en crise à l’ère du numérique*, Paris, Armand Colin, 2013.
- > GRAU Oliver (ed.), *MediaArtHistories*, Cambridge, MIT Press, 2006.
- > GROSOLI Marco and MASSUET Jean-Baptiste, *La capture du mouvement ou le mouvement de l’invisible*, Rennes, Presses universitaires de Rennes, 2014.
- > HADJIOANNOU Markos, *From Light to Byte. Towards an Ethics of Digital Cinema*, Minneapolis, University of Minnesota Press, 2012.
- > ISAACS Bruce, *The Orientation of Future Cinema:*

*Technology, Aesthetics, Spectacle*. London, Bloomsbury, 2013.

- > LEBLANC Gérard and THOUARD Sylvie (eds.), *Numérique et transesthétique*, Villeneuve d'Ascq, Presses universitaires du Septentrion, 2012.
- > LENORMAND Charlie, *Du grain au bruit: vers une sensitométrie numérique ciné*, Final dissertation, ENS Louis-Lumière, 2016.
- > MANOVICH Lev, *Software Takes Command*, New York & London, Bloomsbury, 2013.
- > MANOVICH Lev, *The Language of New Media*, Cambridge, MIT Press, 2001.
- > MAYET Antoine, *Approche pratique de l'utilisation du bruit interne des caméras numériques dans l'élaboration d'une texture image*, Final dissertation, ENS Louis-Lumière, 2019.
- > MORRISSEY Priska, "De l'étalonnage traditionnel à l'étalonnage numérique, suivi d'un entretien avec Isabelle Julien," *Positif*, n° 603, May 2011, p. 95-98.
- > RODOWICK David N., *The Virtual Life of Film*, Cambridge, Harvard UP, 2007.
- > ROSSAAK Eivind (ed.), *Between Stillness and Motion. Film, Photography, Algorithms*, Amsterdam, Amsterdam University Press, 2011.
- > ROUX Martin, *Persistance ou influence de l'esthétique argentine sur les technologies numériques*, Final dissertation, ENS Louis Lumière, Paris, 2012.
- > ROY André, *Dictionnaire général du cinéma. Du cinématographe à Internet: art, technique, industrie*, Québec, Fides, 2007.
- > STEWART Garrett, *Framed Time. Towards a Postfilmic Cinema*, Chicago, University of Chicago Press, 2007.
- > UTTERSON Andrew, *From IBM to MGM. Cinema at the Dawn of the Digital Age*, Londres, British Film Institute / Palgrave Macmillan, 2011.
- > WINSTON Brian, *Media Technology and Society: A History, from the Telegraph to the Internet*, London, Routledge, 1998.

## Archaeology, History and Aesthetics of Cinematographic Techniques

- > ALBERA François, and TORTAJADA Maria (dir.), *Ciné-dispositifs. Spectacles, cinéma, télévision, littérature*, Lausanne, L'Âge d'Homme, 2011.
- > ALBERA François and TORTAJADA Maria (eds.), *Cinema beyond Film. Media Epistemology in the Modern Era*, Amsterdam, Amsterdam University Press, 2010.
- > ARNAUD Gilles, CAINJO Yann, MAGNIEN Baptiste, *Étude sur les caractéristiques des capteurs*, CST, February 2019.
- > BAREFOOT Guy, *Gaslight Melodrama. From Victorian London to 1940's Hollywood*, London, Bloomsbury, 2016.
- > BELTON John, "Technology and Aesthetics of Film Sound," In BRAUDY Leo and COHEN Marshall, *Film Theory and Criticism*, Oxford University Press, 1999.
- > BELTON John (dir.), Dossier "Film Technology," *Film History*, vol. 11, n° 1, Spring 1999.
- > BENNET Bruce, FURSTENEAU Marc and MACKENZIE Adrian (dir.), *Cinema and Technology: Cultures, Theories, Practice*, London, Palgrave, 2008.
- > COHEN (dir.), *Film Theory and Criticism: Introductory Readings*, Oxford, Oxford UP, 1999, p. 376-384.
- > COMOLLI Jean-Louis, "Technique et idéologie. Caméra, perspective, profondeur de champ," *Cahiers du cinéma*, n° 229-241, 1971-1972.
- > CRARY Jonathan, *L'art de l'observateur. Vision et modernité au XIXe siècle*, Nîmes, Editions Jacqueline Chambon, 1994.
- > DESHAYS Daniel, *Entendre le cinéma*, Paris, Klincksieck, 2010.
- > ELSAESSER Thomas, *Film History as Media Archaeology*, Amsterdam University Press, 2016.
- > FOURNIER Jean-Louis, *La sensitométrie: les sciences de l'image appliquées à la prise de vues* ►



*cinématographique*, Editions Dujarric, 2006.

- > GAUDREAUULT André and LEFEBVRE Martin (dir.), *Techniques et technologies du cinéma: modalités, usages et pratiques des dispositifs cinématographiques à travers l'histoire*, Rennes, Presses universitaires de Rennes, coll. "Le Spectaculaire," 2015.
- > GAUDREAUULT André, RUSSELL Catherine and VERONNEAU Pierre, *Le Cinématographe, nouvelle technologie du XXe siècle / The Cinema, A New Technology for the 20th Century*, Lausanne, Payot, 2004.
- > GUERIN Frances, *A Culture of Light. Cinema and Technology in 1920's Germany*, Minneapolis, University of Minnesota Press, 2005.
- > KEATING Patrick, *Hollywood Lighting. From the silent era to Film noir*, New York, Columbia University Press, 2010.
- > KITTLER Friedrich, *Gramophone, Film, Typewriter*, Dijon, Les Presses du Réel, 2018.
- > KITTLER Friedrich, *Optical Media*, Cambridge, Polity Press, 2010.
- > LIGENSA Annemone and KREIMEIER Klaus (eds.), *Film 1900: Technology, Perception, Culture*, New Barnet, John Libbey Publishing Ltd., 2009.
- > MANNONI Laurent, *La Machine cinéma, de Méliès à la 3D*, Paris, La Cinémathèque française, Lienart Edition, 2016.
- > MANNONI Laurent, *Le mouvement continué. Catalogue illustré de la collection des appareils de la cinémathèque française*, Milan and Paris, Mazzotta and Cinémathèque française, 1996.
- > MANNONI Laurent, *Le grand art de la lumière et de l'ombre. Archéologie du cinéma*, Paris, Nathan, 1995.
- > MANNONI Laurent, de FERRIERE LE VAYER Marc and DEMENY Paul, *Georges Demeny, pionnier du cinéma*, Douai, Editions Pagine, 1997.
- > MALTHETE Jacques and SALMON Stéphanie (eds.), *Recherches et innovations dans l'industrie du cinéma.*

*Les cahiers des ingénieurs Pathé (1906-1927)*, Paris, Fondation Jérôme Seydoux – Pathé, 2017.

- > MORRISSEY Priska, and RUIVO Céline (dir.), "Le cinéma en couleurs: procédés et usages avant la fin des années 1950," *1895 : revue d'histoire du cinéma*, n° 71, AFRHC and Rennes 2-Technes, 2013.
- > MOUËLLIC Gilles, "Improvisation et son direct. Entre théories du son et mutations technologiques," *Cinémas: revue d'études cinématographiques / Cinémas: Journal of Film Studies*, vol. 24, n° 1, 2014, p. 83-102.
- > "Entretien avec François Musy – ingénieur du son," *YouTube*, Interview filmed within the framework of the TECHNÈS doctoral committee with the sound engineer François Musy on September 28, 2017, l'ÉCA, Lausanne, URL: <[https://www.youtube.com/watch?v=sn52K\\_wsjHo](https://www.youtube.com/watch?v=sn52K_wsjHo)>
- > NEALE Steve, *Cinema and Technology: Image, Sound, Colour*, Bloomington, Indiana UP, 1985.
- > PINEL Vincent, *Vocabulaire technique du cinéma*, Paris, Armand Colin, 2008.
- > PISANO Giusy, *Une archéologie du cinéma parlant*, Paris, CNRS, 2004
- > REVAULT D'ALLONNES Fabrice, *La lumière au cinéma*, Paris, Cahiers du cinéma, 1991.
- > RYAN Roderick T., *A History of Motion Picture Color Technology*, London & New York, Focal Press, 1977.
- > SALT Barry, *Moving into Pictures. More on Film History, Style, and Analysis*, London, Starword, 2006.
- > SALT Barry, *Film Style and Technology: History and Analysis*, London, Starwood, 1983.
- > STEWART Garrett, *Between Film and Screen. Modernism's Photo Synthesis*, Chicago, University of Chicago Press, 1999.
- > TOMAS David, *Beyond the Image Machine: A History of Visual Technologies*, London, Continuum, 2004.
- > TURQUETY Benoît, *Inventer le cinéma. Épistémologie: problèmes, machines*, Lausanne, L'Âge d'Homme, 2014.

- > VIVIÉ Jean, *Prélude au Cinéma. De la préhistoire à l'invention*, Paris, L'Harmattan, 2006.
- > VIVIÉ Jean, *Traité général de la technique du cinéma. vol. 1: Historique et développement de la technique cinématographique*, Paris, B. P. I., 1945.
- > WOLLEN Peter, "Cinema and Technology: An Overview," In *Readings and Writings: Semiotic Counter-Strategy*, London, Verso, 1982, p. 169-177.
- > ZIELINSKI Siegfried, *Deep Time of the Media. Towards an Archaeology of Hearing and Seeing by Technical Means*, Cambridge, MIT Press, 2006.
- > ZIELINSKI Siegfried, *Audiovisions: Cinema and Television as Entr'actes in History*, Amsterdam, Amsterdam UP, 1999.

## Guides and Manuals on Cinematographic Techniques

- > AMERICAN CINEMATOGRAPHER MANUAL, Hollywood, The ASC Press, 10<sup>th</sup> Ed., 2013.
- > AMERICAN CINEMATOGRAPHER MANUAL, Hollywood, The ASC Press, 9<sup>th</sup> Ed., 2007 (two volumes).
- > AMERICAN CINEMATOGRAPHER MANUAL, Hollywood, The ASC Press, 8<sup>th</sup> Ed., 2001.
- > AMERICAN CINEMATOGRAPHER MANUAL, Hollywood, The ASC Press, 7<sup>th</sup> Ed., 1993.
- > AMERICAN CINEMATOGRAPHER MANUAL, Hollywood, The ASC Press, 6<sup>th</sup> Ed., 1986.
- > AMERICAN CINEMATOGRAPHER MANUAL, Hollywood, The ASC Press, 5<sup>th</sup> Ed., 1980.
- > AMERICAN CINEMATOGRAPHER MANUAL, Hollywood, The ASC Press, 4<sup>th</sup> Ed., 1973.
- > AMERICAN CINEMATOGRAPHER MANUAL, Hollywood, The ASC Press, 3<sup>rd</sup> Ed., 1969.
- > AMERICAN CINEMATOGRAPHER MANUAL, Hollywood, The ASC Press, 2<sup>nd</sup> Ed., 1967.
- > AMERICAN CINEMATOGRAPHER MANUAL, Hollywood, The ASC Press, 1<sup>st</sup> Ed., 1960.
- > AMERICAN CINEMATOGRAPHER VIDEO MANUAL, Hollywood, The ASC Press, 3<sup>rd</sup> Ed., 2001.
- > AMERICAN CINEMATOGRAPHER VIDEO MANUAL, Hollywood, The ASC Press, 2<sup>nd</sup> Ed., 1994.
- > AMERICAN CINEMATOGRAPHER VIDEO MANUAL, Hollywood, The ASC Press, 1<sup>st</sup> Ed., 1992.
- > BELLAÏCHE Philippe, *Les secrets de l'image vidéo*, Eyrolles, 10th edition, 2015.
- > BRARD Pierre, *Technologie des caméras. Formats, standard & substandard. Manuel de l'opérateur*, Quincy, Editions techniques européennes nouvelles, 2<sup>nd</sup> edition, 1985.
- > BRARD Pierre, *Technologie des caméras. Formats, standard & substandard. Manuel de l'assistant-opérateur*, Quincy, Editions techniques européennes nouvelles, 1<sup>st</sup> édition, 1975.
- > CARLSON Verne and CARLSON Sylvia, *Professional Cameraman's Handbook*, Boston & London, 1970, 1974, 1981.
- > CORNWELL-CLYNE Adrian, *Colour cinematography*, London, Chapman & Hall, 1951.
- > DUCOM Jacques, *Le Cinématographe scientifique et industriel. Son évolution intellectuelle, sa puissance éducative et morale. Traité pratique de cinématographie*, Paris, Albin Michel, 1924.
- > ELKINS David E., *The Camera Assistant's Manual*, London & New York, Routledge, A Focal Press Book, 7<sup>th</sup> Ed., 2020.
- > ELKINS David E., *The Camera Assistant's Manual*, London & New York, Routledge, A Focal Press Book 6<sup>th</sup> Ed., 2013.
- > ELKINS David E., *The Camera Assistant's Manual*, Boston, Elsevier / Focal Press, 5<sup>th</sup> Ed., 2009.
- > ELKINS David E., *The Camera Assistant's Manual*, Boston, Elsevier / Focal Press, 4<sup>th</sup> Ed., 2005.
- > ELKINS David E., *The Camera Assistant's Manual*, Boston, Focal Press, 3<sup>rd</sup> Ed., 2000.

- > ELKINS David E., *The Camera Assistant's Manual*, Boston, Focal Press, 2<sup>nd</sup> Ed., 1996.
  - > ELKINS David E., *The Camera Assistant's Manual*, Boston, Focal Press, 1<sup>st</sup> Ed., 1991.
  - > FOURNIER Jean-Louis, *La sensitométrie: les sciences de l'image appliquées à la prise de vues cinématographique*, Editions Dujarric, 2006.
  - > HART Douglas C. Hart, *The Camera Assistant. A Complete Professional Handbook*, Boston, Focal Press, 1996.
  - > LE TECHNICIEN DU FILM, MANUEL, Paris, 1<sup>st</sup> edition, 1973.
  - > LOBEL Léopold, *La technique cinématographique. Projection, fabrication des films*, Paris, Dunod, 1922.
  - > REUMONT François, *Le guide Image de la prise de vues cinéma*, Paris, Editions Dujarric, 2<sup>nd</sup> edition, 2006.
  - > REUMONT François, *Le guide image de la prise de vues cinéma*, Paris, Editions Dujarric, 1<sup>st</sup> edition, 2002.
  - > STONE R. Brian and WAHLIN Leah, *The Theory and Practice of Motion Design. Critical Perspectives and Professional Practice*, New York & Oxon, Routledge, A Focal Press Book, 2018.
  - > VIVIÉ Jean, *Cinéma & Télévision en Couleurs*, Paris, B. P. I., 1954.
- Jean-Pierre Beauviala and the Aaton Company**
- > ANDRY Richard, "Un régal de tourner à la main avec une Aaton," In *Lettre AFC*, n° 297, may 2019
  - > BEAUVIALA Jean-Pierre, "Réponse aux réactions sur Penelope 3perf qui exclut le 4perf, donc le Scope anamorphosé 1:2," *Lettre de l'AFC*, n°148, November 2005, p.17-18.
  - > BEAUVIALA Jean-Pierre, "Aaton Pénélope Delta, trouvailles & nouveautés," *Sonovision*, supplément au n° 570, February 2012, p. 24-25.
  - > BEAUVIALA Jean-Pierre and FERENCZI Aurélien, "Aaton, la caméra qui redonne du grain aux images," *Télérama*, [Online], January 2013, <http://www.telerama.fr/cinema/aaton-la-camera-qui-redonne-du-grain-aux-images.91462.php>
  - > BERGALA Alain, HENRY Jean-Jacques and TOUBIANA Serge, "Entretien avec Jean-Pierre Beauviala," *Cahiers du Cinéma*, n° 285-288, February-March 1978.
  - > BERGALA Alain, HENRY Jean-Jacques and NINEY François, "Stratégie/Temps: Entretien avec Jean-Pierre Beauviala," *Cahiers du Cinéma*, n° 409, June 1988, p. 70-75.
  - > BERGALA Alain, HENRY Jean-Jacques and NINEY François, "Fausse sortie des usines Aaton et entrée des artistes dans le montage virtuel," *Cahiers du Cinéma*, n° 410, July-August 1988, p. 70-75.
  - > BILLOT Josselin, "Test de la Pénélope Delta d'Aaton," *cinematographie.info*, published: 09/06/2013, URL: <https://cinematographie.info/index.php?/topic/3464-test-de-la-penelope-delta-daaton/?s=5200dc6072f6f511d6867cdda7e8d985>.
  - > BLOCH Dominique, "Dossier: caméras numérique," Dossier de la CST, n° 143, January 2013.
  - > BOZON Céline, "Jean-Pierre, avec élégance," *Lettre AFC*, n° 297, May 2019.
  - > BRAWLEY John, "Aaton Delta Penelope," [johnbrawley.wordpress.com](http://johnbrawley.wordpress.com), published: 17/09/2012, URL: <https://johnbrawley.wordpress.com/2012/09/17/aaton-delta-penelope/>.
  - > CHAMPETIER Caroline, "Jean-Pierre ou le temps retrouvé," *Lettre AFC*, n° 297, May 2019.
  - > CHAMPETIER Caroline, "Vous avez dit organique," *Lettre AFC*, n° 215, published: 11/12/2011, URL: <https://www.afcinema.com/Vous-avez-dit-organique-7356.html>.
  - > CHAMPETIER Caroline and BOVIALA Julien, "Jean-Pierre Beauviala 1937-2019," release published by the Cinémathèque Française, published: 09/04/2019, URL:

- <https://www.cinematheque.fr/article/1396.html>.
- > CHATELET Thomas and FAVEL Thomas, "Aaton Pénélope: présentation à l'IBC 2008," cinematographie.info, published: 2008, updated 01/06/2009, URL: <https://cinematographie.info/index.php?/topic/1116-aaeton-%20openelope-presentation%20-%20a%20-libc-2008/>.
  - > CHATELET Thomas, "Jean-Pierre Beauviala: le magasin numérique 4K de l'Aaton Pénélope (interview with Jean-Pierre Beauviala at the Micro-Salon 2010, on 13/02/2010)," cinematographie.info, published: 26/02/2010, URL: <https://cinematographie.info/index.php?/topic/1720-jean-pierrebeauviala-%20le-magasin-numerique-4k-de-laaeton-penelope-videoenglish/>.
  - > DURAND Nathalie, "Le cinéma organique," *Lettre AFC*, n° 297, May 2019.
  - > DE BATTISTA Gérard, "Les gentils ronrons de l'Aaton," *Lettre AFC*, n° 297, May 2019.
  - > DE MARI Alexia, "Entretien avec Jean-Pierre Beauviala, sur le fonctionnement de l'entreprise Aaton," In *L'équipe de film, innovations et inventions*, BONHOMME Bérénice and LABROUILLÈRE Isabelle (dir.), article published in issue n° 2 of *Création Collective au Cinéma*, 2019, p. 205-215, URL: <https://f.hypotheses.org/wp-content/blogs.dir/6566/files/2019/06/Alexia-CCN-n2.pdf>.
  - > EQUIPE ANGENIEUX, "Au revoir Monsieur Beauviala," *Lettre AFC*, n° 297, May 2019.
  - > FAVEL Thomas, *L'invention dans les techniques de prise de vue*, Génèse d'une caméra: Pénélope, Mémoire de fin d'étude, FEMIS, June 2007.
  - > FAVEL Thomas, "Un hommage à Jean-Pierre Beauviala dans les *Cahiers du cinéma*," *Lettre AFC*, n° 298, 30/05/2019.
  - > FAUER Jon, "Aaton Delta Penelope," *Film and Digital Times*, n° 45, December 2011.
  - > FAUER Jon, "Aaton Penelope Delta," *fdtimes.com*, published: 11/09/2012, URL: <https://www.fdtimes.com/2012/09/11/aaton-penelope-delta/>.
  - > FAUER Jon, "Aaton 4K Penelope-Delta," *fdtimes.com*, published: 25/04/2010, URL: <https://www.fdtimes.com/2010/04/25/aaton-4k-penelope-delta/>.
  - > GARBIT Philippe, "Surpris par la nuit – Jean-Pierre Beauviala 2/2 (original broadcast: 03/10/2007)," *Les Nuits de France Culture*, URL: <https://www.franceculture.fr/emissions/les-nuits-de-france-culture/surpris-par-la-nuit-jean-pierre-beauviala-22-1ere-diffusion-03102007>.
  - > FERENCZI Aurélien, "Aaton, la caméra qui redonne du grain aux images," *telerama.fr*, published: 04/01/2013, updated: 09/06/2020, URL: <https://www.telerama.fr/cinema/aaton-la-camera-qui-redonne-du-grain-aux-images,91462.php?xtatc=INT-60>.
  - > GARSON Charlotte, "La pente Beauviala," *Cahiers du Cinéma*, n° 626, September 2007, p. 64-65.
  - > GAUTIER Éric, "Jean-Pierre Beauviala a accompagné ma vie de chef opérateur," *Lettre AFC*, n° 297, May 2019.
  - > GENTIL Dominique, "Le discret battement cœur des caméras Aaton," *Lettre AFC*, n° 297, May 2019.
  - > GODARD Jean-Luc and BEAUVIALA Jean-Pierre, "Génèse d'une caméra," *Cahiers du Cinéma*, n° 348-350, June 1983.
  - > GRIFFON Claire, "La Delta Pénélope, caméra numérique d'Aaton pas comme les autres," *mediakwest.com*, published: 15/04/2013, URL: <https://mediakwest.com/la-delta-penelope-camera-numerique-d-aaton-pas-comme-les-autres/>.
  - > GRIZET Denis, *Les appareils de prise de vues de la société Aaton (1971-2013). Du "direct" au "numérique": techniques et esthétiques*, Master's thesis, Universités de Rennes 2.
  - > GUICHARD Éric, "Jean-Pierre Beauviala, inventivité et création artistique," *Lettre AFC*, n° 298, 30/05/2019.
  - HENRY Jean-Jacques, "Entretien avec Jean-Pierre

Beauviala," *Cahiers du Cinéma*, n° 325, June 1981, p. 91-94.

> HENRY Jean-Jacques, "Dix ans après," *Cahiers du Cinéma*, n° 409, June 1988, p. 71.

> HUMEAU Jean-Michel, "Mille images et mille vies," *Lettre AFC*, n° 297, May 2019.

> MAGNIEN Baptiste, "Grenoble: 1 – Genève: 0," *Lettre AFC*, n° 297, May 2019.

> MANNONI Laurent, "Les archives Aaton à la Cinémathèque française," *Lettre AFC*, n° 297, May 2019.

> PAMPURI Emmanuel, "Micro Salon 2012, Penelope Delta, a star is born..." pampuri.wordpress.com, published : 12/02/2012, URL: <https://pampuri.wordpress.com/2012/02/12/micro-salon-2012-aaton-penelope-delta-a-star-is-born/>

> REUMONT François, "Le pétrole et les idées," *Lettre AFC*, n° 298, 30/05/2019.

> SORREL V., "L'invention de la caméra Éclair 16: du direct au synchrone," *1895: Revue d'histoire du cinéma*, n° 82, Summer 2017, p. 127.

> TESSE Jean-Philippe, "Camera-man: entretien avec Jean-Pierre Beauviala," *Cahiers du Cinéma*, n° 672, November 2011, p. 24-25.

> FLICHY Patrick, *L'Innovation technique*, Paris, La Découverte, 2003.

> GUCHET Xavier, *Pour un humanisme technologique. Culture, technique et société dans la philosophie de Gilbert Simondon*, Paris, Presses universitaires de France, 2010.

> GUILLERME Jacques, SEBESTIK Jan, "Les commencements de la technologie," *Thalès*, no 12, 1968, p. 1-72 (repr. *Documents pour l'histoire des techniques*, no 14, 2007, p. 49-122, p. 84).

> MAUSS Marcel, *Techniques, technologie et civilisation*, Paris, Presses universitaires de France, 2012.

> SIMONDON Gilbert, *Du mode d'existence des objets techniques (1958)*, Paris, Aubier, 2012.

> SIMONDON Gilbert, *Sur la technique*, Paris, Presses universitaires de France, 2014.

## History of Techniques

> BOWELER Peter, MORUS Iwan R., *Making Modern Science: A Historical Survey*, Chicago, University of Chicago Press, 2005.

> DAUMAS Maurice, *Histoire générale des techniques*, 5 vol., Paris, Presses universitaires de France, 1962-1975.

> EDGERTON David, "Innovation, Technology, or History: What is the Historiography of Technology About?" *Technology and Culture*, vol. 51, n° 3, 2010, p. 680-697.

> FRANCASTEL Pierre, *Art et technique aux XIXe et XXe siècles*, Paris, Éditions de Minuit, 1956.



## Cahier Louis-Lumière

Annual journal

### Editorial committee

- Raphaëlle Bertho, Maître de Conférences, Université de Tours - Intru.
- Nicole Brenez, Professeure des Universités, Université Paris 3 - IRCAV.
- Kira Kitsopanidou, Professeure des Universités, Université Paris 3 - IRCAV.
- Martin Lefebvre, Professeur des Universités, Concordia University, Canada - Figura NT2.
- Mathieu Saladin, Maître de Conférences, Université Paris 8 - Teamed.
- Makis Solomos, Professeur des Universités, Université Paris 8 - Musidance.
- Myriam Tsikounas, Professeure des Universités, Université Paris 1 - ISOR/CRH.
- Benoît Turquety, Professeur des Universités, Université de Lausanne, Suisse - UNIL.

### Director of publication

Vincent Lowy,  
Director of ENS Louis-Lumière

### Head of editorial committee (n°14 – 2021)

Gilles Mouëllic and Giusy Pisano

### Gilles Mouëllic and Giusy Pisano wish to acknowledge and warmly thank :

- each contributor for their work and submissions;
- Vincent Sorrel for his outstanding contributions and assistance in the coordination of this issue;
- Caroline Champetier for her collaboration;
- Joël Daire and Laurent Mannoni for their support;
- Alexia de Mari for facilitating access to the Aaton archive;
- Elisa Carfantan and Marie Marquelet for their proofreading;
- Elodie Bourgneuf and Catherine Davis for their translations;
- the entire ENS Louis-Lumière team for their commitment
- Naomi Nicolas Kaufman and Jérémy Piot

### Contributors

Marianne Bauer  
Bérénice Bonhomme  
Bruno Carrière  
Caroline Champetier  
Simon Daniellou  
Alexia de Mari  
Antony Fiant  
Hélène Fleckinger  
Thomas Godefroy  
Éric Hurtado  
Pascal Martin  
Jean-Baptiste Massuet  
Valentine Miraglia  
Vanessa Nicolazic  
Camille Pierre  
Martin Roux  
Vincent Sorrel  
Frédéric Tabet  
Nicolas Tixier  
Thomas Weyland

### Translator

Elodie Bourgneuf

### Project manager Méhdi

Aït-Kacimi  
(com@ens-louis-lumiere.fr  
and 01 84 67 00 10)

### Design and layout

Guillaume Colrat  
Studio Axiome

### ENS Louis-Lumière

#### faculty members

David Faroult,  
Maître de conférences  
Véronique Figini,  
Maître de conférences  
Pascal Martin,  
Professeur des Universités  
Laurent Millot,  
Maître de conférences  
Giusy Pisano,  
Professeure des Universités  
Director of ENS Louis-Lumière:  
Vincent Lowy,  
Professeur des Universités

#### Director of Research

Raïssa Lahcine

#### Distribution

Pollen

#### Copyright

Authors retain their copyright of their contributions.  
ENS Louis-Lumière retains copyright of the full issue-images : all rights reserved.

Printed in France by STIPA in June 2021.

Copyright registration : May 2020.

ISBN : 978-2-9576795-0-8

ISSN : 2-9520267-9-3

Total or partial reproduction of this journal is strictly prohibited.

According to the French copyright law of March 11th 1957, you may not copy, reproduce or in any way exploit any such content.





# ÉCOLE NATIONALE SUPÉRIEURE LOUIS-LUMIÈRE

The ENS Louis-Lumière offers initial professional training – theoretical, practical, technical and artistic. Under the supervision of the Ministry of Higher Education, Research and Innovation, the school operates as a public institution, recruiting students who have completed two years of post-high school education, and selecting these students via a competitive entrance exam. The ENS Louis-Lumière offers training in three distinct programs: Cinema, Photography and Sound. Each program culminates in a diploma conferring a Master's degree. The training is free of charge for all students.

The ENS Louis-Lumière also offers training in continuing professional education and participates in applied research projects.

Created in 1926 at the instigation of legends such as Louis Lumière and Léon Gaumont, and recognized as a pioneering school in the realms of film and photography, the school moved to the Cité du Cinéma in July 2012. In July 2013, it launched an « equal opportunities » year-long program to promote equity in its entrance exam. Since 2014, the ENS Louis-Lumière has been an associate member of the University Paris Lumières (UPL).

## Research

The ENS Louis-Lumière is involved in ArTec, a French Graduate School belonging to the University Paris Lumières. Launched in September 2018, ArTec (« Art, Technologies, Digital, Human Mediations & Creations ») is also a university research school opening doors to graduate studies at the doctoral level. ArTec questions the role of new technologies, human mediation and the ethics of a post-digital age.

Research projects carried out by ENS Louis-Lumière and its partners share a common perspective on issues at the heart of their training. These are structured around four transversal and transdisciplinary pillars :

- Technological innovations and emerging practices
- Research and artistic creation
- The history of techniques, technologies, and practices
- Scientific expertise and articulation

The *Cahier Louis-Lumière* is an academic journal dedicated to the promotion of the relations between research and creation. It targets researchers and anyone wishing to know more about the state of research in the fields of sound and image : professionals, manufacturers, cultural institutions, students, ...

Past issues

2003 : *Questions de cinéma*

2004 : *Espaces pluriels, images et son*

2005 : Territoires audiovisuels, errances, itinérances et frontières

2006 : *Les dispositifs* (Proceedings of the international conference organized by ENS Louis-Lumière and University of Marne-la-Vallée)

2007 : *Coupe, découpe, découpage*

2008 : *Vide, vacuité, désœuvrement*

2009 : *Nouvelles perspectives pour les photographes professionnels* (Proceedings of the conference organized by ENS Louis-Lumière at the French Senate)

2010 : *Un cinéma du subjectif* (Proceedings of the conference organized by ENS Louis-Lumière and the Ecole supérieure d'Audiovisuel at University Toulouse II le Mirail)

2015 : *Mémoires d'écoles*

2016 : *Archéologie de l'audiovisuel*

2018 : *Le cinéma face aux histoires du regard*

2019 : *Art filmique et expérimentations optiques contemporaines*

2020 : *Les dispositifs immersifs : vers de nouvelles expériences de l'image et du son*

Print editions available for order.

Online editions available on [www.persee.fr](http://www.persee.fr)

and [www.ens-louis-lumiere.fr](http://www.ens-louis-lumiere.fr)